

# AIRLESS DIAPHRAGM GIOTTO LINER PLUS

Line striper with  
diaphragm pump



**Intentionally blank page**

# Larius the ideal choice for achieving professional performance.

## WELL PROVEN TECHNICAL QUALITY FOR ANY ON-GROUND MARKING APPLICATION

The LARIUS airless line markers successfully join product performance with operator requirements and allow the marking and the maintenance of any kind of pavement lines on roads, motorways, airports, pedestrian crossings, cycle paths, yards and wherever is required by the Highway Code with regards to horizontal road signs, guaranteeing perfect lines on different surfaces.

The airless technology provides the high pressure spraying of the paint through a nozzle having centesimal dimensions as compared to the traditional low pressure spraying in which the paint flow is atomized through the air contribution.



## Advantages of use

### Net and clear lines on any kind of pavement with one coat only.

With a single coat the line is defined evenly: the line made by airless spraying is linear, clean-cut and marked thanks to the flat cut nozzle and without the jagged due to the turbulences caused by air.

### Reduction of Over spray.

The airless operated marking guarantees the absence of the classic "Overspray", that is the dispersion of paint particles which is typical in the traditional air painting.

This translates, further than in a saving of paint, in a better protection for health of the operator and for environment.

### Saving of paint up to 30%.

Thanks to the absence of Overspray almost all of the used product is applied on the surface without any waste.

### Reduction of the vibrations.

The reduction of the vibrations ensures the best in industry quality of lines.

### The paint dries quickly.

The airless operation requires that filtered paint specifically formulated for airless application is used, this means, by itself, even paint, smooth and uniform texture which will not return any crust nor will become neither jelly-like nor thick.

The paint holds tightly on any kind of pavement, with an excellent visibility and resistance to wear caused both by traffic and weather elements.

High quality paints guarantee a faster application speed, a better durability of the visibility of the line and a pleasant aesthetic result.

### Reflective bead application.

Reflective beads can be applied using a gravity dispenser operated by the same command which operates

the paint gun. The spheres automatically fall onto the freshly marked line. No paints with pre-mixed beads can be used.

### 50 litre non-stick hopper.

Thanks to the big capacity of the hopper marking times are extended thanks to the absence of frequent interruptions to perform colour changes.

### Template works and curved marking.

The gun can be released from its support in just a few seconds and, thanks to the 10 meters pipe it is connected to, it allows any template work, on walls as well.

The front wheel helps to mark lines close to the kerb and to mark arches and curves.

### Intuitive use by the operator.

The operator commands are located right on the handlebar to adjust the operation of the line marker in the most handy way.

### Optional equipment.

Airless line markers can be equipped basing on the different needs of the operator for offering a dedicated solution for any marking need.

### Easy cleaning and maintenance.

Cleaning airless line markers is quick thanks to the absence of pressurized tanks to be cleaned and thus colour change times are extremely short both if using the can or the non stick paint tank. The high pressure of the airless line marker clears the spraying area from dirt and so it does not require that the ground is previously cleaned.

A regular cleaning at the end of the work is sufficient to keep the machine in perfect efficiency, even after prolonged standing periods.

The Larius Super Fast Clean airless nozzles allow that the nozzle is cleaned with a simple rotating movement, without any need to detach it.

Professional line markers for the ideal “line”

# WHERE'S TARMAAC...

*We can make a long “Road” together*



<b>LARIUS®</b> SAMOA Group	<b>MIRÒ LINER PLUS HAND PUSH</b>	<b>DALÌ LINER PLUS HAND PUSH</b>	<b>GIOTTO LINER PLUS SELF-PROPELLED</b>	<b>VIKING LINER</b>
<b>Motor Power</b>	5,5 - HP	5,5 - HP	10 - HP	12,75 - HP
<b>Max. flow rate</b>	2 - l/m	4 - l/m	7 - l/m	8 - l/m
<b>Max. supply</b>	210 bar	210 bar	210 bar	210 bar
<b>Airless guns</b>	N°1 AT 250	N°1 AT 250	N°1 AT 250	N°2 AT 250
<b>Bicomponent product sprayguns</b>				*
<b>Measure of the standard nozzles</b>	1 x 11-40 1 x 13-40 1 x 15-40	1 x 11-40 1 x 13-40 1 x 17-40	1 x 11-40 1 x 13-40 1 x 17-40	2 x 11-40 2 x 13-40 2 x 17-40
<b>Tank lt.50</b>	*	*	*	
<b>Colors</b>	1	1	1	2
<b>Automatic line painting</b>				
<b>Accessories</b>	*	*	*	*
<b>Applications</b>	Small line painting jobs and road maintenance	Medium-sized line painting jobs and road maintenance	Medium-sized line painting jobs and road maintenance	Medium-sized line painting jobs and road maintenance
<b>Multi-purpose sprayer</b>	*	*	*	*
<b>Weight</b>	60 kg	65 kg	200 kg	110 kg
<b>Dimensions</b>	1200x700x1000	1650x750x1000	1650X750X1000	1650x750x1000

Professional line markers for the ideal "line"

# ... THERE'S LARIUS

*An already marked work when you start.*



EXCALIBUR LINER HAND PUSH	ZEUS LINER HAND PUSH	DRAGON LINER SELF-PROPELLED	EVEREST TH SELF-PROPELLED	K2 ECO SELF-PROPELLED
7 - HP	9 - HP	9,5 - HP	14 - HP	BATTERY
2 - l/m	3,5 - l/m	4,5 - l/m	6,5 - l/m	2,8 - l/m
210 bar	210 bar	230 bar	230 bar	230 bar
N°1 AT 250	N°2 AT 250	N°2 AT 250	N°2 LA95 + N°1 AT 250	N°1 AT 250
1 x 11-40 1 x 13-40 1 x 15-40	2 x 13-40 2 x 15-40 2 x 19-40	2 x 13-40 2 x 17-40 2 x 21-40 1 x 19-40	2 x 13-40 2 x 17-40 2 x 21-40 1 x 19-40	1 x 11-40 1 x 13-40 1 x 17-40
*	*	*	*	*
1	1	1	1	1
		*	*	
*	*	*	*	*
Medium-sized line painting jobs and road maintenance	Medium-sized line painting jobs and road maintenance	Large line painting jobs and road maintenance	Large line painting jobs and road maintenance	Medium-sized line painting jobs and road maintenance
*	*	*	*	*
80 kg	100 kg	220 kg	260 kg	280 kg
1400x600x1050	1650x750x1000	1650x750x1000	2000x800x1100	2000x800x1100

**This manual is to be considered as an English language translation of the original manual in Italian. The manufacturer shall bear no responsibility for any damages or inconveniences that may arise due to the incorrect translation of the instructions contained within the original manual in Italian.**

**Due to a constant product improvement programme, the factory reserves the right to modify technical details mentioned in this manual without prior notice.**



# GIOTTO LINER PLUS

Airless diaphragm road marking machines

## INDEX

INTRODUCTION .....	p.2	<b>J</b> CLEANING AT THE END OF THE WORK .....	p.18
<b>A</b> WORKING PRINCIPLE .....	p.3	<b>K</b> GENERAL MAINTENANCE .....	p.19
<b>B</b> TECHNICAL DATA .....	p.5	Daily .....	p.19
Application fields .....	p.6	Periodically .....	p.19
Nozzles position table.....	p.6	<b>L</b> ROUTINE MAINTENANCE.....	p.19
<b>C</b> DESCRIPTION OF THE EQUIPMENT.....	p.7	Control oil level in the motor .....	p.19
<b>D</b> TRANSPORT AND UNPACKING .....	p.10	Top up hydraulic oil .....	p.19
<b>E</b> SAFETY RULES.....	p.10	Release the suction valve.....	p.19
CONDITIONS OF GUARANTEE.....	p.11	Replacing hydraulic oil .....	p.20
<b>F</b> SETTING-UP.....	p.11	<b>M</b> DESCRIPTION OF THE CONTROLS .....	p.20
Pump unit flexible tube connection .....	p.11	<b>N</b> TROUBLESHOOTING.....	p.22
Starting the motor.....	p.12	<b>O</b> PROBLEMS AND SOLUTIONS .....	p.23
Washing of the new equipment .....	p.13	SPARE PARTS .....	p.25
Preparation of the paint .....	p.14	<b>P</b> HYDRUALIC BODY .....	p.26
<b>G</b> REGULATIONS .....	p.15	<b>Q</b> COMPLETE COLOR BODY .....	p.28
Adjusting the gun position .....	p.15	<b>R</b> COMPLETE MOTOR UNIT .....	p.30
Adjusting the gun support arm .....	p.15	<b>S</b> FILTER GROUP.....	p.32
<b>H</b> OPERATION.....	p.16	<b>T</b> 25 L TANK .....	p.33
Setup procedure .....	p.16	<b>U</b> 50 L TANK.....	p.34
Adjusting pump unit speed.....	p.16	<b>V</b> HIGH PRESSURE SPRAY GUN.....	p.35
<b>I</b> PAINTING OPERACIONES.....	p.16	<b>W</b> ACCESSORIES.....	p.36
Spray adjustment.....	p.17	DECLARATION OF CONFORMITY .....	p.41













**WE ADVISE THE USE OF THIS EQUIPMENT ONLY BY PROFESSIONAL OPERATORS.  
ONLY USE THIS MACHINE FOR USAGE SPECIFICALLY MENTIONED IN THIS MANUAL.**

Thank you for choosing a **LARIUS S.R.L.** product.  
As well as the product purchased, you will receive a range of support services  
enabling you to achieve the results desired, quickly and professionally.



## WARNINGS

The table below provides the meaning of the symbols used in this manual in relation to using, earthing, operating, maintaining, and repairing of this equipment.

	<p>Read this operator's manual carefully before using the equipment. An improper use of this machine can cause injuries to people or things. Do not use this machine when under the influence of drugs or alcohol. Do not modify the equipment under any circumstances. Use products and solvents that are compatible with the various parts of the equipment, and read the manufacturer's warnings carefully. See the Technical Details for the equipment given in the Manual. Check the equipment for worn parts once a day. If any worn parts are found, replace them using <b>ONLY</b> original spare parts. Keep children and animals away from work area. Comply with all safety standards.</p>
	<p>It indicates an accident risk or serious damage to equipment if this warning is not followed.</p>
	<p>It indicates a fire or explosion risk if this warning is not followed. Eliminate all ignition sources such as pilot lights, cigarettes, portable electric lamps and plastic drop cloths. Keep work area free of debris. <b>ONLY</b> use this equipment in a well ventilated area. <b>EARTH ALL THE EQUIPMENT LOCATED IN THE WORK AREA.</b> Do not form connections or switch light switches on or off if the air contains inflammable fumes. If electrical shocks or discharges are encountered the operation being carried out using the equipment must be stopped immediately. Keep a fire extinguisher at hand in the immediate vicinity of the work area.</p>
	<p>It indicates wound and finger squashing risk due to movable parts in the equipment. Tenersi lontano dalle parti in movimento. Do not use the equipment without the proper protection. Before any inspection or maintenance of the equipment, carry out the decompression procedure explained in this manual, and prevent any risk of the equipment starting unexpectedly.</p>
 	<p>Report any risk of chemical reaction or explosion if this warning has not been given. There is a risk of injury or serious lesion related to contact with the jet from the spray gun. If this should occur, <b>IMMEDIATELY</b> contact a doctor, indicating the type of product injected. Do not spray before the guard has been placed over the nozzle and the trigger on the spray gun. Do not put your fingers in the spray gun nozzle. Once work has been completed, before carrying out any maintenance, complete the decompression procedure explained in this manual.</p>
	<p>It indicates important recommendations about disposal and recycling process of products in accordance with the environmental regulations.</p>
	<p>Report any danger of electric shock if the warning and presence of live electrical parts has not been indicated. Store in a dry place and do not expose to the rain. Check that the cables are in good condition. Switch off the equipment and discharge any electricity before cleaning or maintaining the equipment.</p>
	<p>Mark any clamps attached to earth cables. Use <b>ONLY</b> 3-wire extension cords and grounded electrical outlets. Before starting work make sure that the electrical system is earthed and that it complies with safety standards.</p>
   	<p>It is obligatory to wear suitable clothing as gloves, goggles and face shield. Wear clothing that complies with the safety standards in force in the country in which the equipment is used. Do not wear bracelets, earrings, rings, chains, or anything else that may hinder the operator's work. Do not wear clothing with wide sleeves, scarves, ties, or any other piece of clothing that could get tangled up in moving parts of the equipment during the work, inspection, or maintenance cycles.</p>





## A WORKING PRINCIPLE

The **GIOTTO LINER PLUS** is a self-propelled device which was conceived and designed for performing road markings along particularly difficult tracts of uneven road where marking would otherwise be difficult to complete.

The internal combustion engine, mounted upon the undercarriage, powers the alternative piston pump and the alternator which is utilised for charging the battery unit. The wheels are powered by an electric motor which allows for easy operator movement, even on medium-grade inclines.

The control zone allows for the possibility of:

- Activating the dispensing spray gun;
- Enabling or disabling the frontal steering wheel;
- Increasing the motor's Rpm's;
- Enabling / disabling wheel traction;
- Gradually increasing the advancement speed of the self-propelled undercarriage;
- Selecting solid or broken-line painting functionality.

This type of equipment is capable of painting one line at a time in a single color.

The line may be solid or broken.

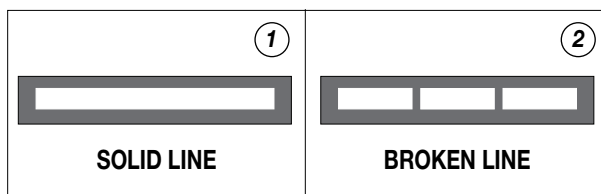

**GIOTTO LINER PLUS** is ideal for medium marking and maintenance jobs.

	<b>Use water or non-refractive solvent filtered paint specifically designed for airless application.</b>
--	--

**GIOTTO LINER PLUS** allows for the marking and maintaining of all types lines on highways, freeways, pedestrian crossings, parking lots and squares, as well as every horizontal marking required by the highway code.

Airless marking has numerous proven benefits with respect to line-markers with pressurised tanks, which have been rendered obsolete by airless-technology line markers.

Airless line-marking guarantees:

- Decreased Environmental Impact;
- Decreased drying time.

The paint dries quickly and the line is defined in a uniform manner with a single coat. The airless function requires the use of filtered paint which is specifically designed for airless application. This means that the paint is homogeneous, of a smooth and uniform consistency and will not form crusts, nor will it become gelatinous or thick. With this airless line-marker, the paint adheres firmly to all types of pavement, with optimal visibility, and is resistance to wear caused both by traffic as well as atmospheric agents.



In the **LARIUS** models, the paint canister can be loaded directly upon the undercarriage or else poured into the non-stick, 50 L tank. In every case, cleaning, maintenance and colour change operations are facilitated.



The line-marker is equipped with a 360° pivoting frontal wheel which even increases the agility of the larger models. High yield, high efficiency, high versatility.

This line-marker utilises non-premixed paints. This allows it to achieve about 30% more yield with respect to standard line-markers. Every model is also an airless spray gun which can be used in the construction/decoration sector together with washable products, enamels, breathable paints and flooring resins. A vast assortment of accessories is available to satisfy every customer demand.

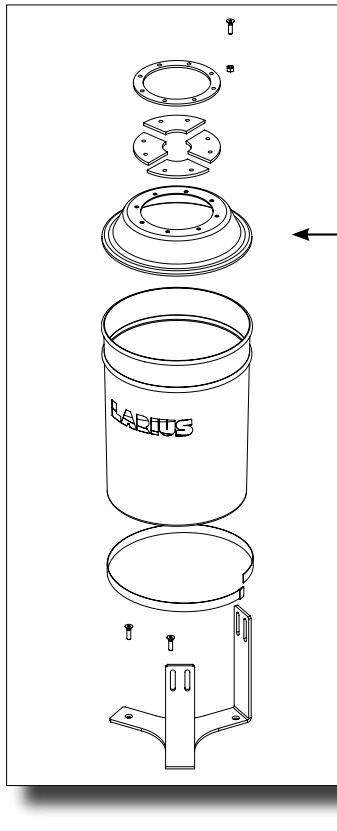

20L tank



50L tank



## B DATI TECNICI

GIOTTO LINER PLUS	
Internal combustion engine power	5 kW
Max. Delivery	8 l/min
Max. pressure	210 bar
Airless spray-gun	AT 250
Size of nozzles	11x40 - 13x40 - 15x40
Tank	50l - 20l
Colors	1
Manual line-marking	series
Applications	Small jobs of line marking and road maintenance
Multi-use sprayer	series
Weight	kg
Lenght	(A) cm
Height	(B) cm
Width	(C) cm
Vibrations	$L_{eq(8h)}=1.5 \text{ m/s}^2$





Standard equipment	Accessories
N°1 Filter with pressure gauge	<b>Rif. 4502</b>
N°1 High pressure tube 3/16", 10 m	manual gun beads
N°1 Recirculation tube	dispenser
N°1 50 L gravity tank + closing valve and extactable filter	<b>Rif. 4038</b>
N°1 Manual airless spray-gun AT250	Laser pointer kit
N°1 Super fast clean base	<b>Rif.4506</b>
N°1 Super fast clean nozzle 11-40	Working spotlight
N°1 Super fast clean nozzle 13-40	<b>Rif. 4711</b>
N°1 Super fast clean nozzle 15-40	Platform
N°1 Tool pack	operator
N°1 Speed control bridge	
N°1 Tool pack	

### APPLICATION FIELDS

- External or underground parking lots (*schools, hotels, airports, supermarkets, train stations, subway stations, ports*);
- Outdoor public areas;
- Industrial and exhibition building zones;
- Freeway service areas and service stations;
- Pedestrian median lines, intersections, bicycle tracks, reserved lanes;
- Marking of indoor and outdoor logistic areas
- Sports and play grounds.

### NOZZLES POSITION TABLE

Nozzle height from ground	20-degree angle Line Width	40-degree angle Line Width	60-degree angle Line Width
10 cm	~ 3 cm	~ 5 cm	~ 10 cm
15 cm		~ 7 cm	~ 13 cm
20 cm	~ 6 cm	~ 8 cm	~ 16 cm
25 cm		~ 10 cm	~ 20 cm
30 cm	~ 10 cm	~ 12 cm	~ 23 cm
35 cm			~ 26 cm



## C DESCRIPTION OF THE EQUIPMENT

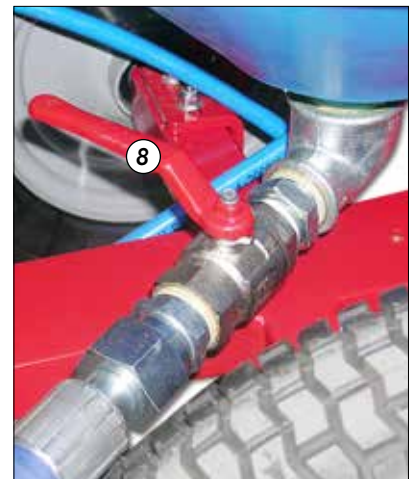
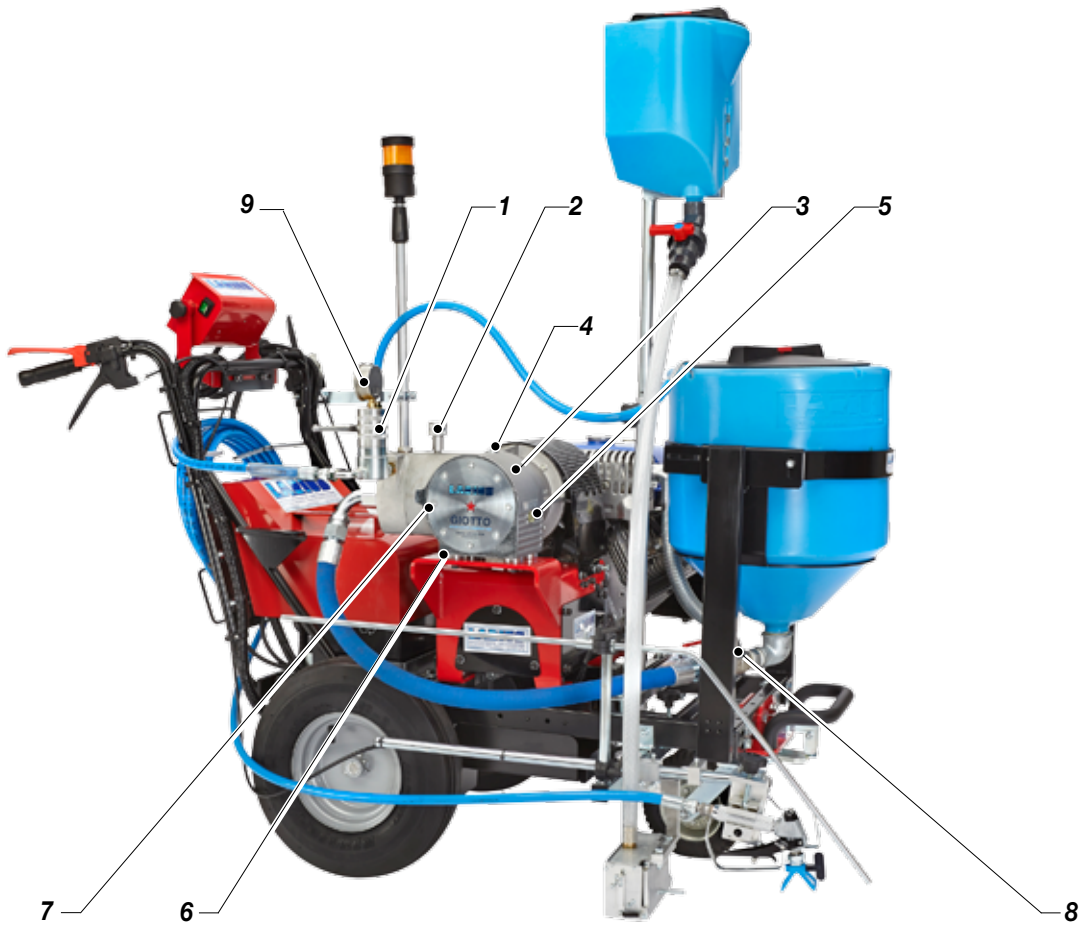

POS.	Description
1	Filtro prodotto
2	Valvola regolazione pressione
3	Gruppo pompante
4	Tappo di carico olio
5	Tappo livello olio

POS.	Description
6	Tappo di scarico olio
7	Filtro olio
8	Valvola di pescaggio
9	Manometro controllo pressione

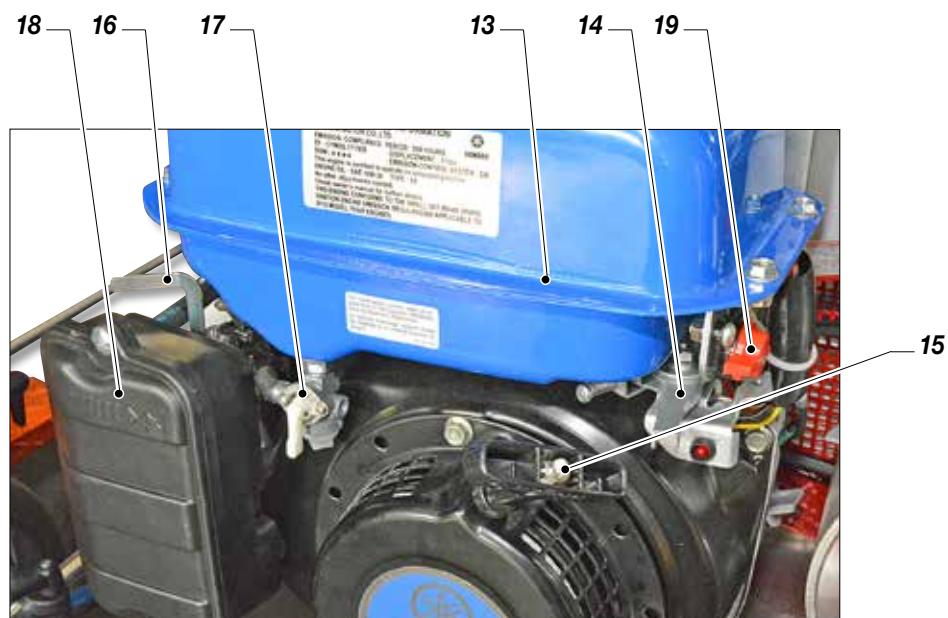

POS.	Description
10	LT. 50 tank
11	Refractive sphere tank
12	Flashing light
13	Fuel tank
14	Accelerator

POS.	Description
15	Start-up cord
16	Cold start-up lever
17	Fuel tap
18	Air filter
19	On / off switch

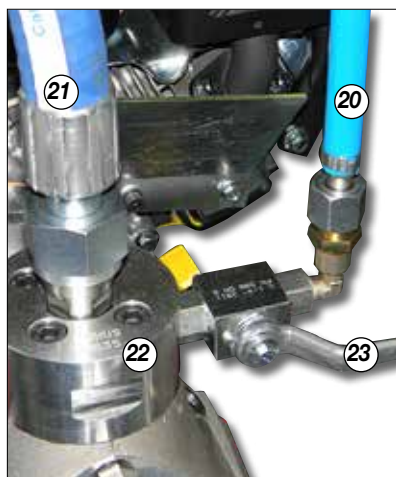

POS.	Description
20	Recirculation tube
21	Product feeding tube
22	Color unit
23	Recirculation valve

POS.	Description
24	AT 250 gun
25	Spraying gun feeding tube
26	Castor wheel
27	Refractive sphere distributor unit



## D TRANSPORT AND UNPACKING

- The packed parts should be handled as indicated in the symbols and markings on the outside of the packing.
- Before installing the equipment, ensure that the area to be used is large enough for such purposes, is properly lit and has a clean, smooth floor surface.



The user is responsible for the operations of unloading and handling and should use the maximum care so as not to damage the individual parts or injure anyone.

To perform the unloading operation, use only qualified and trained personnel (truck and crane operators, etc.) and also suitable hoisting equipment for the weight of the installation or its parts.

Follow carefully all the safety rules.

The personnel must be equipped with the necessary safety clothing.

- The manufacturer will not be responsible for the unloading operations and transport to the workplace of the machine.
- Check the packing is undamaged on receipt of the equipment. Unpack the machine and verify if there has been any damage due to transportation. In case of damage, call immediately **LARIUS** and the Shipping Agent. All the notices about possible damage or anomalies must arrive timely within 8 days at least from the date of receipt of the plant through Registered Letter to the Shipping Agent and to **LARIUS**.



The disposal of packaging materials is a customer's competence and must be performed in accordance with the regulations in force in the country where the plant is installed and used.



It is nevertheless sound practice to recycle packaging materials in an environment-friendly manner as much as possible.

## E SAFETY RULES

- THE EMPLOYER SHALL TRAIN ITS EMPLOYEES ABOUT ALL THOSE RISKS STEMMING FROM ACCIDENTS, ABOUT THE USE OF SAFETY DEVICES FOR THEIR OWN SAFETY AND ABOUT THE GENERAL RULES FOR ACCIDENT PREVENTION IN COMPLIANCE WITH INTERNATIONAL REGULATIONS AND WITH THE LAWS OF THE COUNTRY WHERE THE PLANT IS USED.
- THE BEHAVIOUR OF THE EMPLOYEES SHALL STRICTLY COMPLY WITH THE ACCIDENT PREVENTION AND ALSO ENVIRONMENTAL REGULATIONS IN FORCE IN THE COUNTRY WHERE THE PLANT IS INSTALLED AND USED.
- **KEEP YOUR WORK PLACE CLEAN AND TIDY. DISORDER WHERE YOU ARE WORKING CREATES A POTENTIAL RISK OF ACCIDENTS.**
- ALWAYS KEEP PROPER BALANCE AVOIDING UNUSUAL STANCE.
- BEFORE USING THE TOOL, ENSURE THERE ARE NOT DAMAGED PARTS AND THE MACHINE CAN WORK PROPERLY.
- ALWAYS FOLLOW THE INSTRUCTIONS ABOUT SAFETY AND THE REGULATIONS IN FORCE.
- KEEP THOSE WHO ARE NOT RESPONSIBLE FOR THE EQUIPMENT OUT OF THE WORK AREA.
- **NEVER EXCEED THE MAXIMUM WORKING PRESSURE INDICATED.**
- **NEVER POINT THE SPRAY GUN AT YOURSELVES OR AT OTHER PEOPLE. THE CONTACT WITH THE CASTING CAN CAUSE SERIOUS INJURIES. IN CASE OF INJURIES CAUSED BY THE GUN CASTING, SEEK IMMEDIATE MEDICAL ADVICE SPECIFYING THE TYPE OF THE PRODUCT INJECTED. NEVER UNDERVALUE A WOUND CAUSED BY THE INJECTION OF A FLUID.**
- ALWAYS DISCONNECT THE SUPPLY AND RELEASE THE PRESSURE IN THE CIRCUIT BEFORE PERFORMING ANY CHECK OR PART REPLACEMENT OF THE EQUIPMENT.
- NEVER MODIFY ANY PART IN THE EQUIPMENT. CHECK REGULARLY THE COMPONENTS OF THE SYSTEM. REPLACE THE PARTS DAMAGED OR WORN.
- TIGHTEN AND CHECK ALL THE FITTINGS FOR CONNECTION BETWEEN PUMP, FLEXIBLE HOSE AND SPRAY GUN BEFORE USING THE EQUIPMENT.
- ALWAYS USE THE FLEXIBLE HOSE SUPPLIED WITH STANDARD KIT. THE USE OF ANY ACCESSORIES OR TOOLING OTHER THAN THOSE RECOMMENDED IN THIS MANUAL, MAY CAUSE DAMAGE OR INJURE THE OPERATOR.
- THE FLUID CONTAINED IN THE FLEXIBLE HOSE CAN BE VERY DANGEROUS. HANDLE THE FLEXIBLE HOSE CAREFULLY. DO NOT PULL THE FLEXIBLE HOSE TO MOVE THE EQUIPMENT. NEVER USE A DAMAGED OR A REPAIRED FLEXIBLE HOSE.



Read carefully and entirely the following instructions before using the product. Please save these instructions in a safe place.





The unauthorised tampering/replacement of one or more parts composing the machine, the use of accessories, tools, expendable materials other than those recommended by the manufacturer can be a danger of accident.

The manufacturer will be relieved from tort and criminal liability.







 The high speed of the product in the hose can create static electricity through discharges and sparks. It is suggested to earth the equipment.

 The pump is earthed through the earth cable of the supply. The gun is earthed through the high pressure flexible hose.

All the conductors near the work area must be earthed.

- NEVER SPRAY OVER FLAMMABLE PRODUCTS OR SOLVENTS IN CLOSED PLACES.
- NEVER USE THE EQUIPMENT IN POTENTIALLY EXPLOSIVE ENVIRONMENTS.

 Always check the product is compatible with the materials composing the equipment (*pump, spray gun, flexible hose and accessories*) with which it can come into contact. Never use paints or solvents containing halogen hydrocarbons (*as the methylene chloride*).

 If these products come into contact with aluminium parts can provoke dangerous chemical reactions with risk of corrosion and explosion.

 IF THE PRODUCT TO BE USED IS TOXIC, AVOID INHALATION AND CONTACT BY USING PROTECTION GLOVES, GOGGLES AND PROPER FACE SHIELDS.





 TAKE PROPER SAFETY MEASURES FOR THE PROTECTION OF HEARING IN CASE OF WORK NEAR THE PLANT.

## CONDITIONS OF GUARANTEE

 The conditions of guarantee do not apply in the following situations:

- improper washing and cleaning of components causing malfunction, wear or damage to the equipment or any of its parts;
- improper use of the equipment;
- use that does not conform with applicable national legislation;
- incorrect or faulty installation;
- modifications, interventions and maintenance that have not been authorised by the manufacturer;
- use of non-original spare parts or parts that do not correspond to the specific model;
- total or partial non-compliance with the instructions provided.

## F SETTING-UP

### TUBE CONNECTIONS

#### Flexible re-circulation tube connection

- Connect the flexible re-circulation tube (F1) to the connector (F2) ensuring to tighten the fittings (*the use of two wrenches is suggested*).

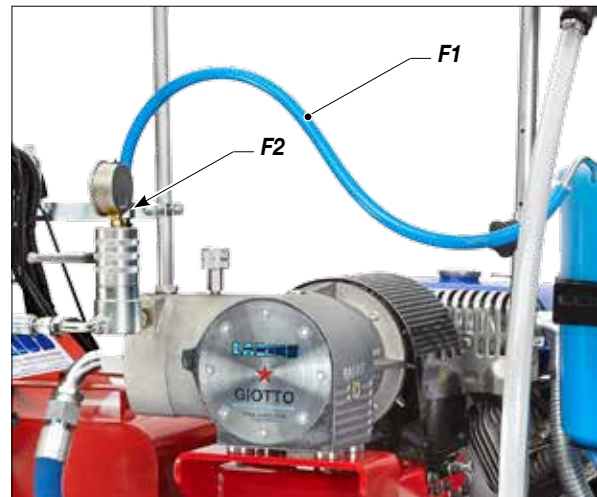

#### Pump unit flexible tube connection

- Connect the product suction flexible tube (F3) to the connector (F4) ensuring to tighten the fittings (*the use of two wrenches is suggested*).





### Flexible tube and spray gun connection

- Connect the flexible tube (F5) to the connector (F6) ensuring to tighten the fittings (*the use of two wrenches is suggested*).

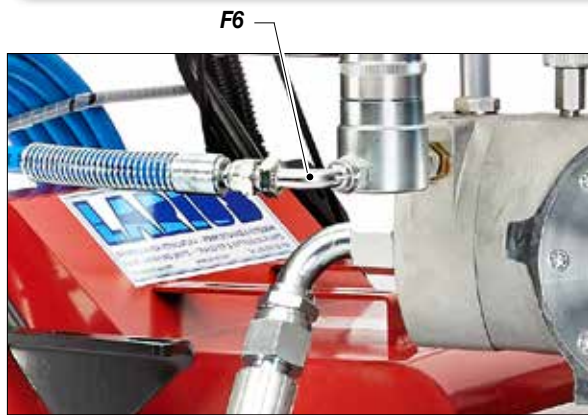
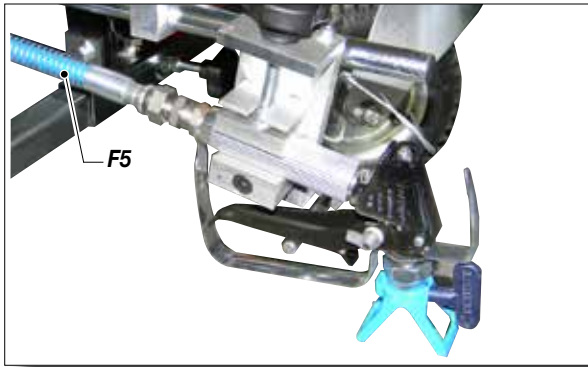

- It is recommended to use the hose provided with the standard kit.  
**NEVER** use a damaged or a repaired flexible hose.  
**NEVER** use sealants on fittings' threads.

### STARTING THE MOTOR

In order to start the motor, proceed as follows:

- Fill the fuel tank (F7).

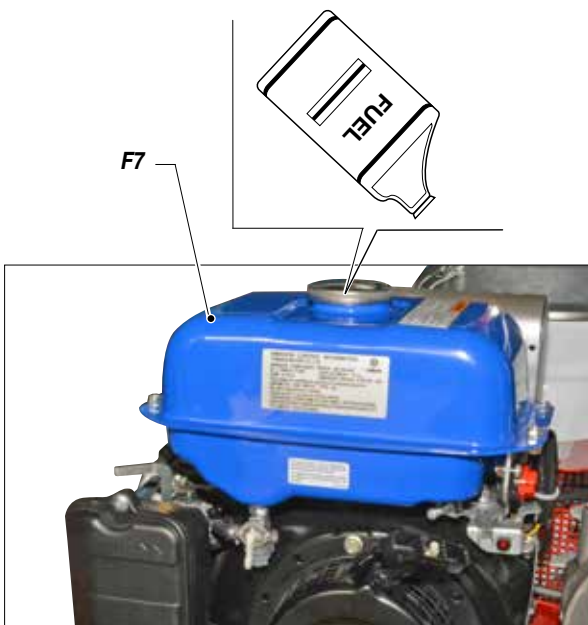

- Open the fuel tap (F8) and position it to "ON" (I).



- Pull lever (F9) for first start-up (*only when cold*).



- Turn the equipment's switch (F10) to ON (I)

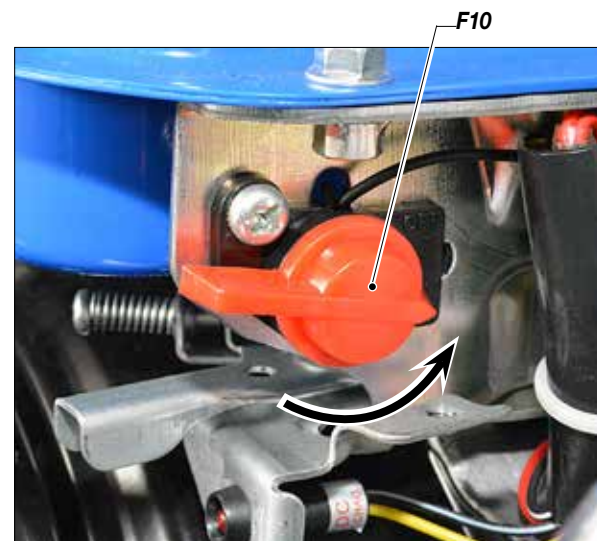



- Bring the accelerator lever (F11) to about 1/2 of its run.

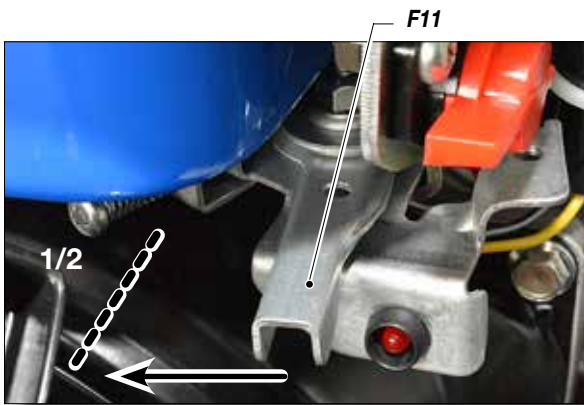

- Ensure the gun (F13) is without nozzle.

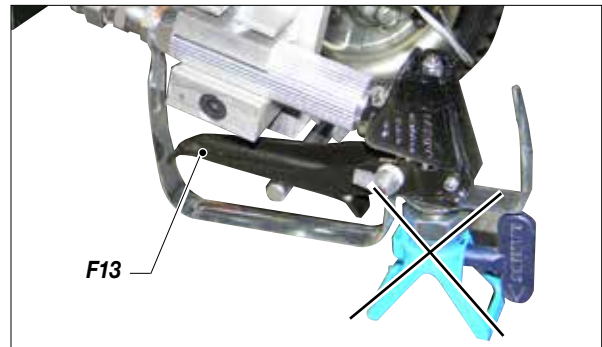

- Pull the lever (F12) for the first cold start up.

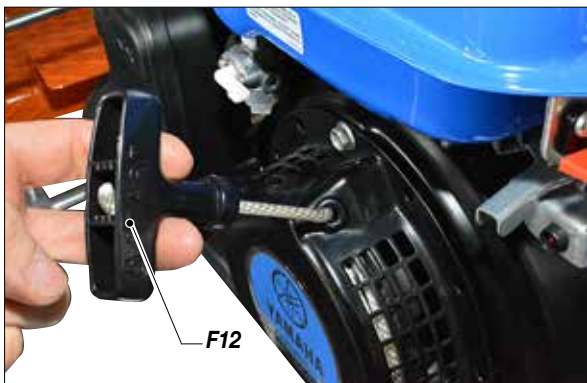

- Open the product output tap (F14).

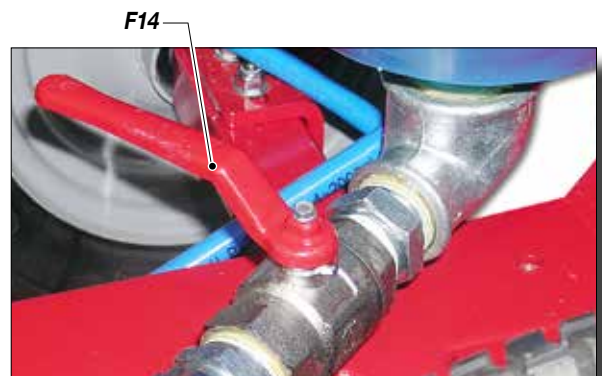

**WASHING OF THE NEW EQUIPMENT**

- The equipment has already been adjusted at our factory with light mineral oil left inside the pumping group as protection. Therefore, wash with diluent before sucking the product.
- Fill the product tank with wash fluid.
- Clean the inside of the tank with a brush.

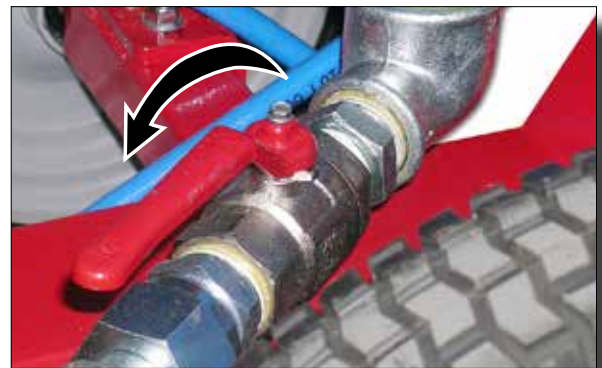

- Open the recirculating-safety valve (F15).

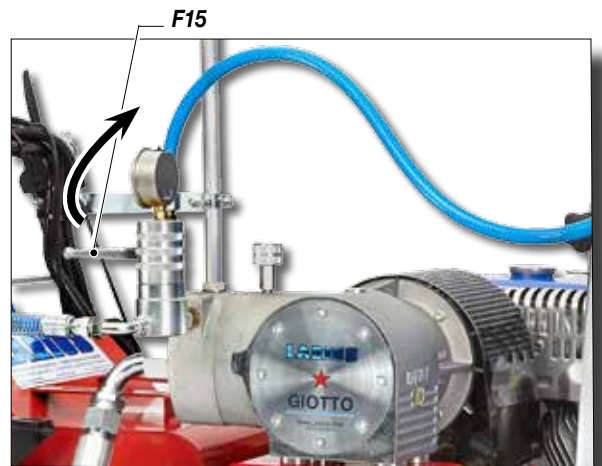



- Start the motor following the indications provided in the chapter “**STARTING THE MOTOR**”.
- Rotate the pressure setting knob (F16) slightly clockwise so that the machine operates at minimum power.

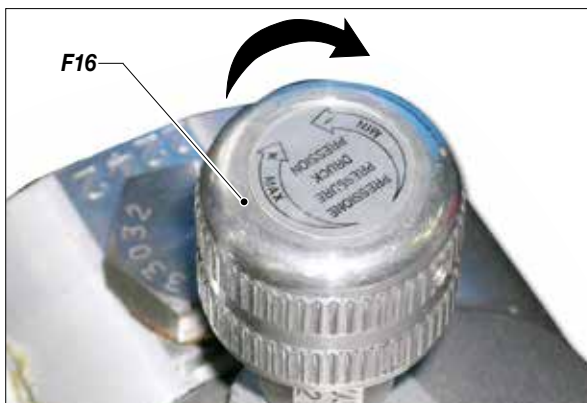

- Visually check that the wash fluid starts to re-circulate within the tank (F17).

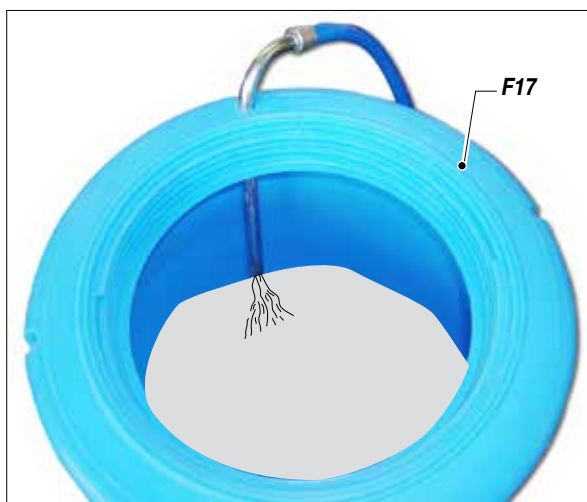

- Once the wash fluid has circulating enough, close the recirculating-safety valve (F15).

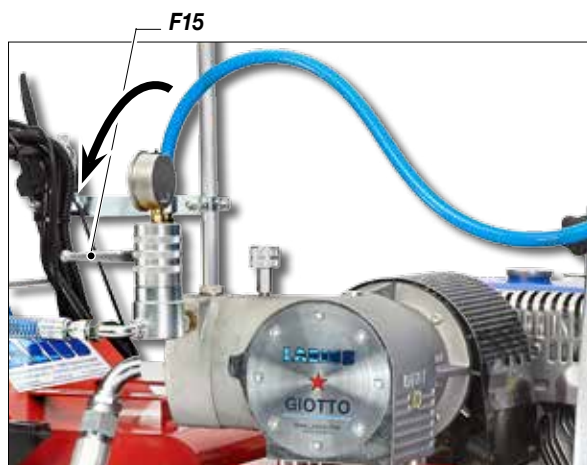

- Remove the gun (F13) from its support and point it into a container (F18). Hold the trigger down (*to perform the cleaning*) until clean solvent comes out, or else until all of the wash fluid has been expelled from the tank.

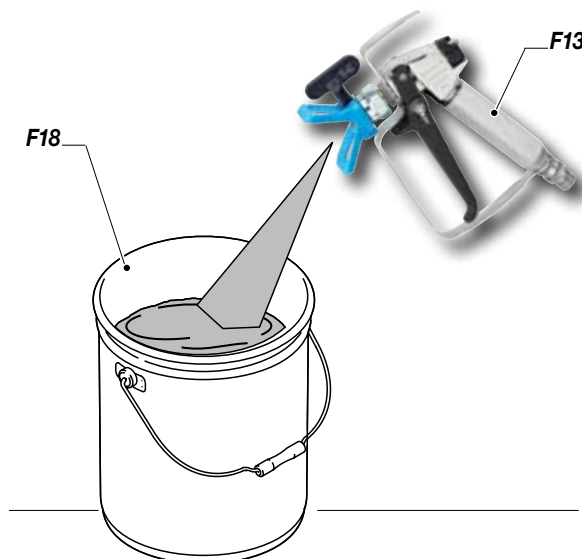

Repeat the same operations with clean solvent if necessary.

- After having completed the wash operations, bring the handle to its MIN position (F17) and point the gun (F13) into a collection container (F18) and press the trigger to release the residual pressure. Release the trigger when finished.



**NEVER** spray solvents indoors. In addition, it is recommended to keep away from the pump in order to avoid the contact between the solvent fumes and the motor.

- When the pump idles stop the combustion engine.
- At this point the machine is ready. If water-based paints are to be used, after the wash with solvent wash the tank again with soap and water (*repeating the previously described procedures*).
- Insert the manual gun trigger lock and assemble the nozzle.

#### PRODUCT PREPARATION



**MAKE SURE THE PRODUCT IS SUITABLE TO BE USED WITH A SPRAY GUN.**

- Mix and filter the product before using it. For filtration use **CLOSE-MESH** (rif. 214) and **LARGE-MESH** (rif. 215) LARIUS METEX braids.



Make sure the product to be used is compatible with the materials employed for manufacturing the equipment (*stainless steel and aluminium*). Because of that, please contact the supplier of the product.

Never use products containing halogen hydrocarbons (as *methylene chloride*). If these products come into contact with aluminium parts of the equipment, can provoke dangerous chemical reactions with risk of explosion.

- Fill the tank (F19) with the paint.



### ADJUSTING THE GUN SUPPORT ARM

In order to adjust the position of the spray gun (G4) use the knobs (G5-G6).

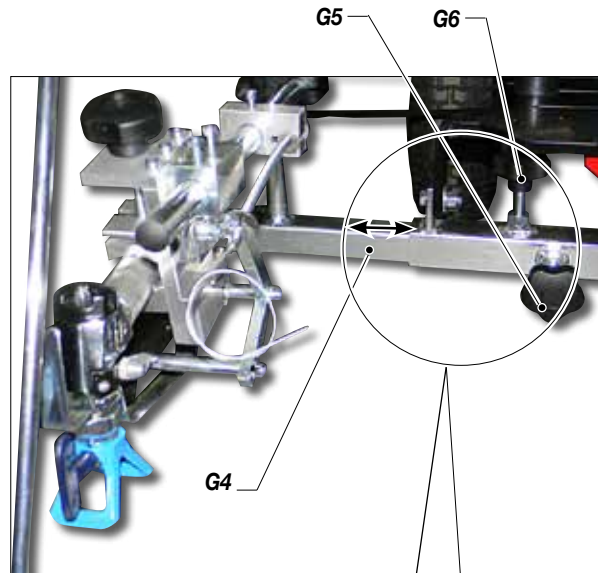

## G REGULATIONS

### ADJUSTING THE GUN POSITION

In order to adjust the position of the spray gun (G1) use the knobs (G2-G3).

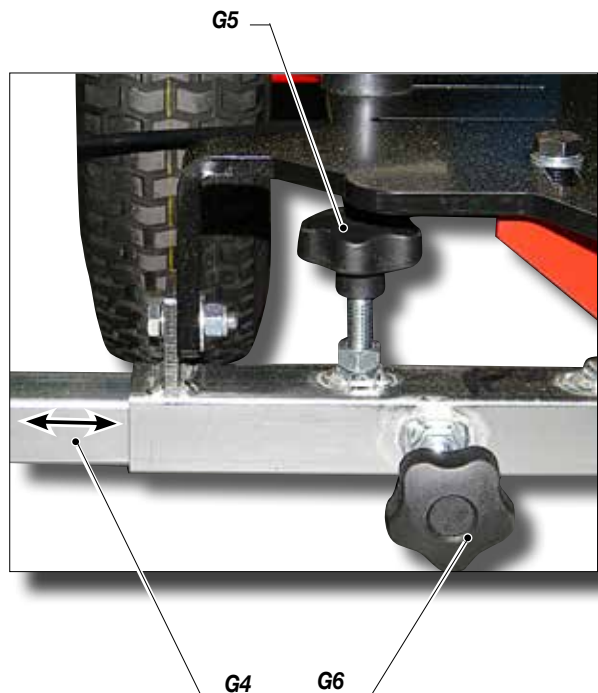
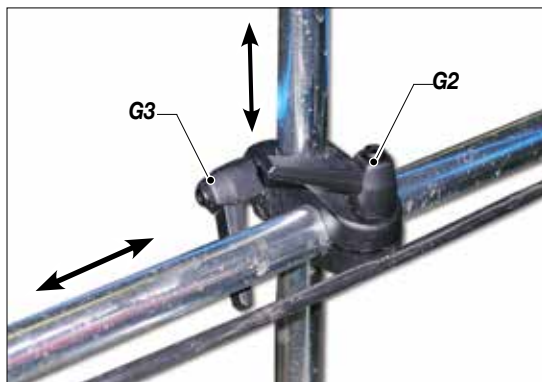
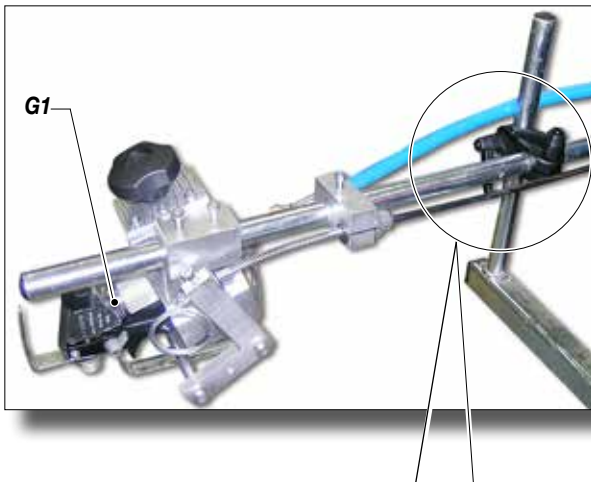



## H OPERATION

### SETUP PROCEDURE

- Use the tooling after performing all the **SETTING UP** operations above described.
- Check that there is enough unleaded petrol.
- Open the product output tap (H1).

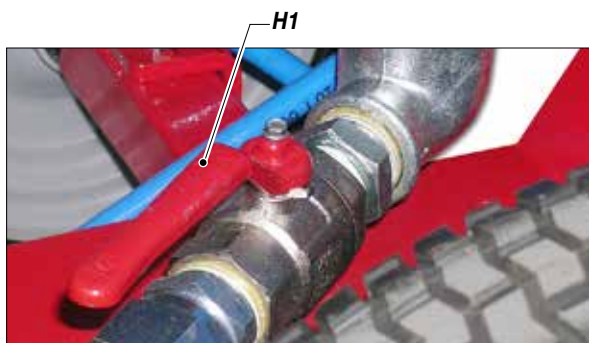

- Turn the equipment knob (H2) on **ON (I)**.



- Start the motor following the indications provided in the chapter "**STARTING THE MOTOR**".
- Make sure that the re-circulation/safety valve (H3) is closed (*spray enabled*).

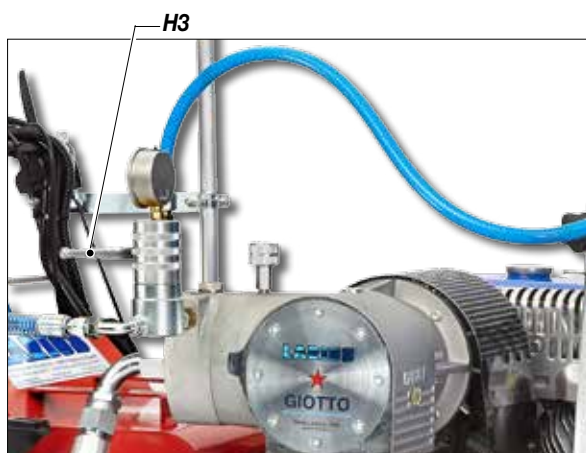

- Turn the pressure adjustment handle clockwise until the desired setting has been reached.

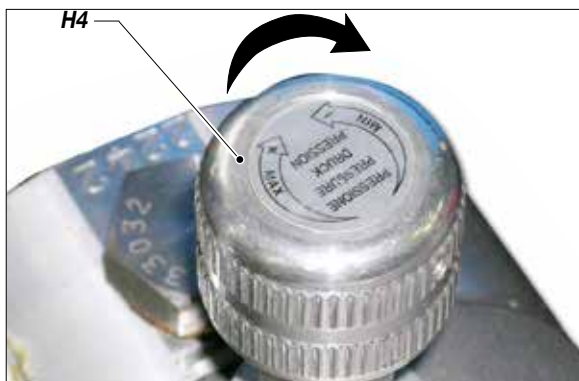

### ADJUSTING PUMP UNIT SPEED

- Move the motor acceleration lever (H5) gently to increase or decrease the speed of the pump.

During the painting operation it is normally recommended to maintain the position of the accelerator lever (H5) at about 3/4 of its maximum run.

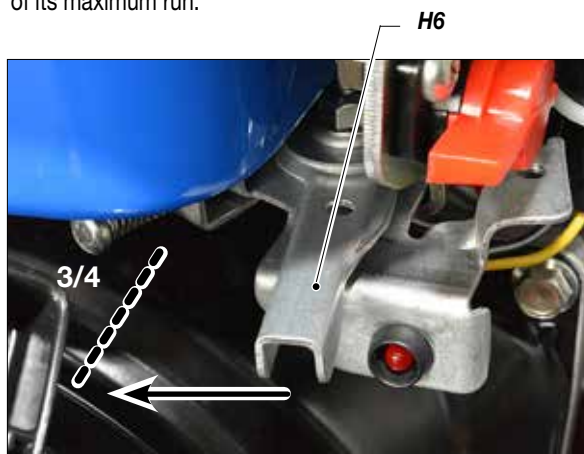

## I PAINTING OPERATIONS

After having performed all of the operations in the "*OPERATION*" chapter, work may be started using the following controls:

- Turn the pressure adjustment handle (I1) clockwise to allow the line-painting gun to dispense paint when the appropriate lever is activated.

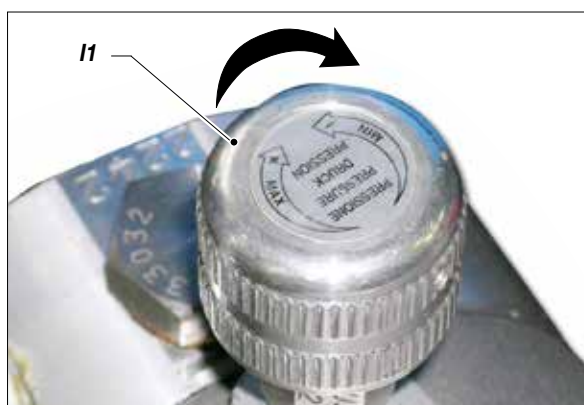



- Press the button (12) located on the control panel.



- If operation is required upon a long rectilinear section, the lever (13) must be placed in its "B" position. A spring-action mechanical stopper will automatically block the front wheel (14) in its straight position, thereby ensuring a straight trajectory for the operator.

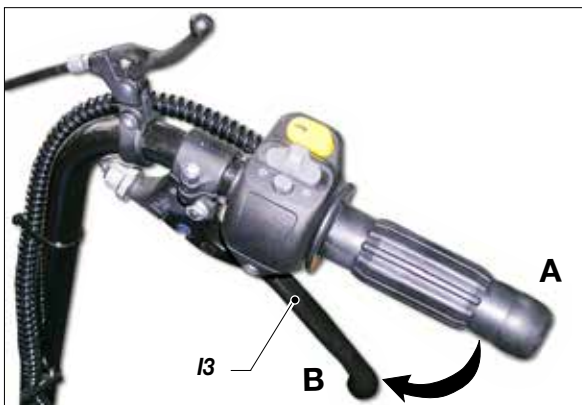

A = Connected block  
B = Disconnected block

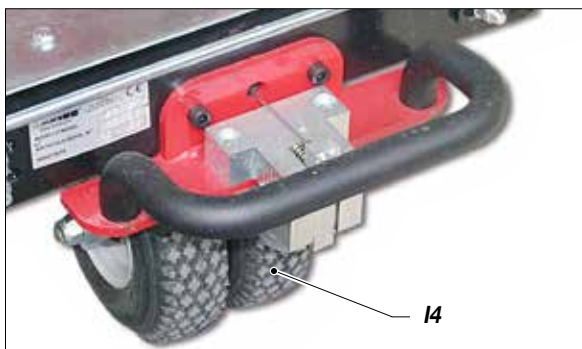

- Use the appropriate handle (15) on the control panel to adjust the machine's advancement speed.

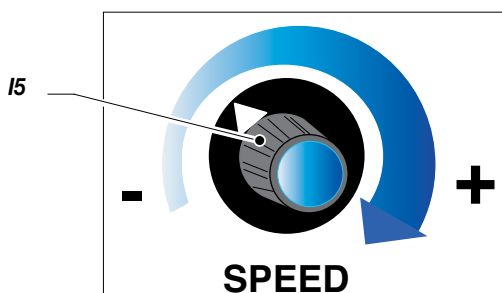

- Use the appropriate switch (16) to select the direction (**FORWARD/REVERSE**). Press the "GEAR" button (17) to initiate the movement of the machine.

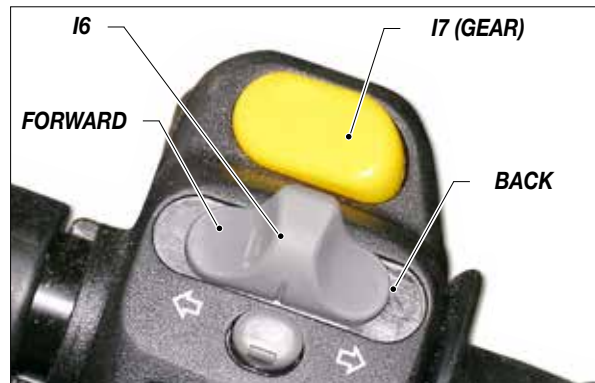

- Hold down the lever (18) on the left side of the control panel while the machine is in motion.

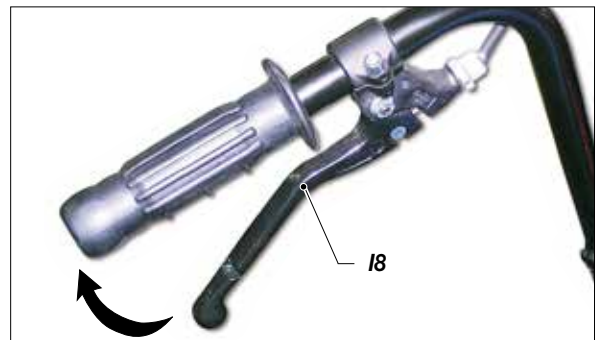

**SPRAY ADJUSTMENT**

- Slowly turn clockwise the pressure control knob to reach the pressure value in order to ensure a good atomization of the product.
- An irregular and marked spray on the sides indicates a low working pressure. On the contrary, a too high pressure causes a high fog ("overspray") and waste of product.
- In order to avoid overthickness of paint, let the gun advance sideways when spraying.
- Always paint with regular parallel bands coats (*manual gun*).
- Keep a safety and constant distance between the gun and the support to be painted and also keep yourselves perpendicular to it.

	<p><b>NEVER</b> point the spray gun at yourselves or at other people.</p> <p>The contact with the casting can use serious injuries. In case of injuries caused by the gun casting, seek immediate medical advice specifying the type of the product injected.</p>
--	---

	<p>When finished using the equipment, follow the decompression and cleaning procedures indicated in the manual and return the levers to their original positions.</p>
--	---



**Recirculating-safety valve:** when working at the maximum pressure available, releasing the gun trigger sudden increases of pressure can occur. In this case, the recirculating-safety valve opens automatically eliminating part of the product from the recirculating tube. Then it closes so as to go back to the first working conditions.

## J CLEANING AT THE END OF WORK

- Reduce pressure to the minimum (turn counterclockwise the pressure control knob (J1)).

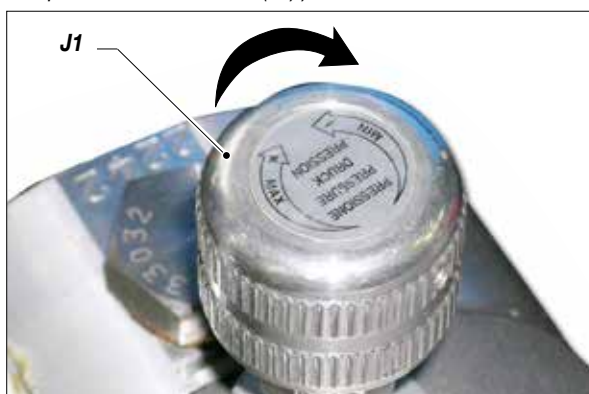

- Release the residual pressure by holding down the trigger of the gun and pointing it into a container.
- Eliminate the paint remaining within the tank (J2) by placing the re-circulation tube (J3) into a container.
- Open the recirculating-safety valve (J4).

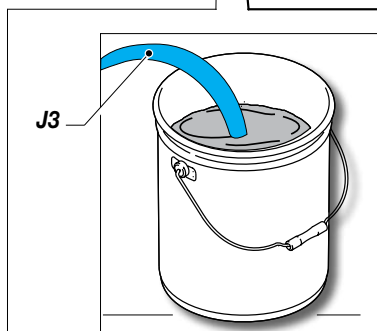
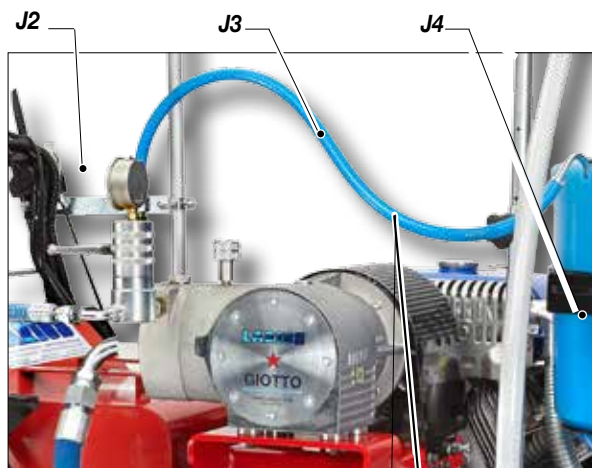

- Turn the pressure adjustment (J1) handle slightly clockwise to make the machine function at minimum pressure (*pump activated*), until the tank has been completely emptied then shut off the pump by bringing the handle (J1) to its minimum position.
- Fill the tank (J2) with wash fluid.
- Clean the walls of the tank with a brush.
- Turn the pressure adjustment (J1) handle slightly clockwise to make the machine function at minimum pressure (*pump activated*).
- Make sure the re-circulation tube (J3) is inserted into a container and wait for clean wash fluid to come out of it.
- Turn the pressure adjustment handle (J1) to minimum (*pump stopped*).
- Place the re-circulation tube back into the tank.
- Keep the gun's trigger pressed to release any residual pressure.
- Remove the nozzle from the gun and wash it separately.
- Closed the recirculating-safety valve
- Turn the pressure adjustment handle (J1) slightly clockwise to make the machine function at minimum pressure (*pump activated*).
- Point the manual gun (J5) into a container (J6), drain the residual paint and wait for the wash fluid to come out clean the entire spraying circuit.

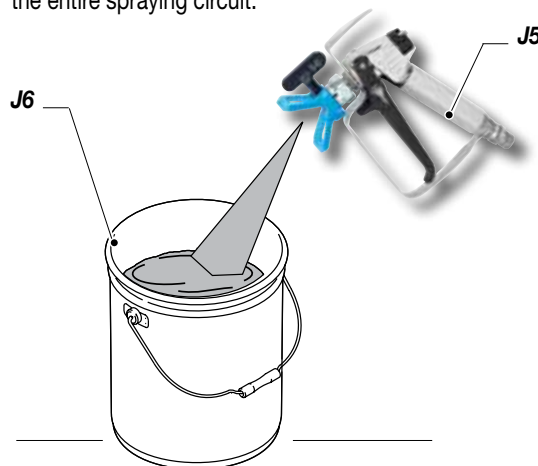

- Empty all of the wash fluid from the tank and turn off the equipment.
- Turn the pressure adjustment handle (J1) to minimum (*pump stopped*).
- Shut off the motor.
- In case of long storage, we recommend you to suck and to leave light mineral oil inside the pumping group and the flexible hose.



**Follow the washing procedure before using again the equipment.**





## K GENERAL MAINTENANCE

 **Discharge the pressure in the pump unit (*open the discharge valve*) before carrying out any maintenance operation.**

### DAILY

- Clean the filters;
- Clean the nozzles;
- Clean all the varnish circuit with a specific product;
- Check the fuel motor (*see the maintenance table*).

### PERIODICALLY

- Check the pumping gaskets draft (*if the product draws, replace gaskets*);
- Clean the mobile parts from the varnish deposits (*spray guns, etc.*);
- Check the gun cables tightening, the wheel block;
- Check that the tubes and all the fittings are correctly locked.

## L ROUTINE MAINTENANCE

### CONTROL THE OIL LEVEL IN THE MOTOR

 **Always check that there is oil in the motor.**

Check the motor oil every 100 working hours via the relevant measuring caps positioned on the bottom of the petrol motor. Top up if necessary.

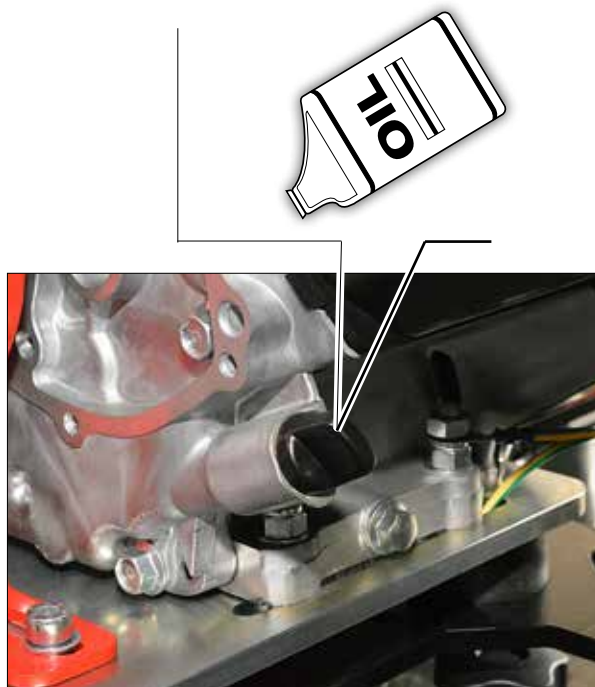

### TOP UP HYDRAULIC OIL

With each start up, check the hydraulic oil level by looking through the gauge (L1) on the side of the hydraulic body; If necessary, use this type of oil to top up the level.

**AGIP DICREA 150 type hidraulic oil**



### RELEASE THE SUCTION VALVE

If the pump malfunctions, release the suction valve fitted on the head of the pump in the following way:

- Remove the suction hose fitting or the suction tank and release the valve by inserting a rigid rod (L2) with a diameter of no more than 15 mm.

 **Add a few drops of oil to make operation easier.**

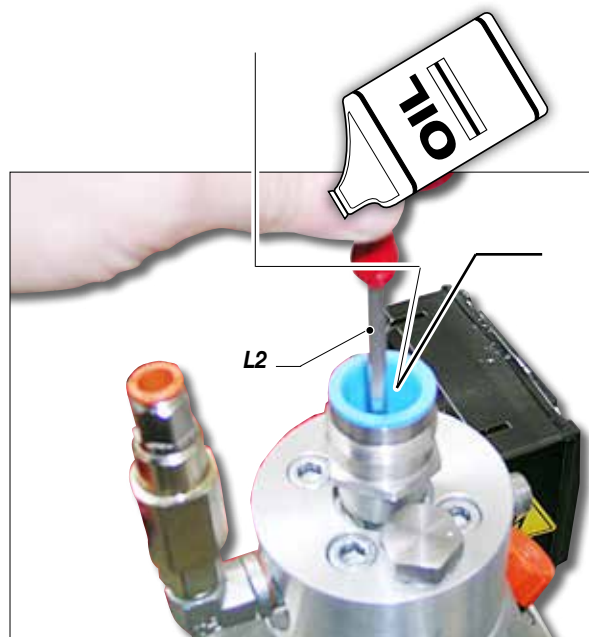



### REPLACING HYDRAULIC OIL

After operating for 100 hours, replace the oil in the pump;

- Discharge the waste oil through the plug (L4) fitted at the bottom of the pump casing.
- Clean the seals on the cap and replace it if worn.
- Clean the filter (L4).
- Clean and, if necessary, replace the worn seals (L4).
- Fill the pump with the recommended oil until it reaches the maximum level the plug (L4).

**AGIP DICREA 150 type hidraulic oil**

- Then, substitute the oil every 250 hours.

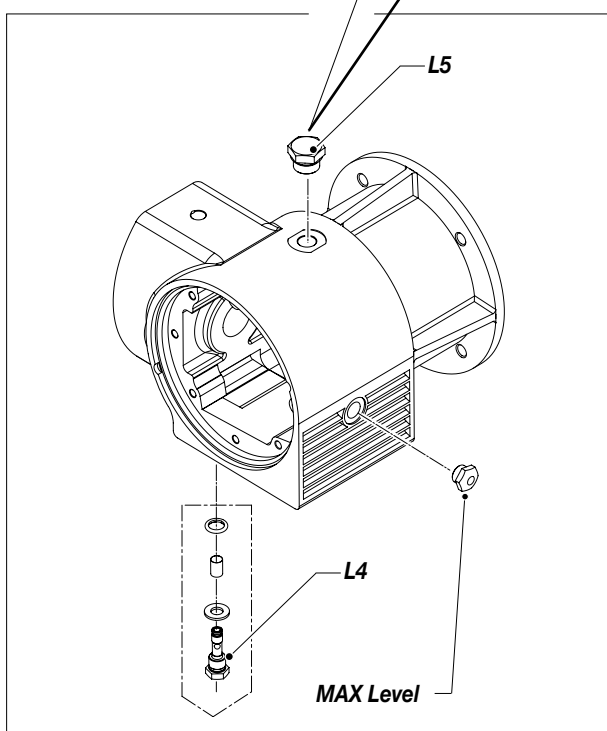

### M DESCRIPTION OF THE CONTROLS

- M1) Directional lever**  
Pull on the lever to release the linear drive lock and allow the machine to perform curved line tracts.
- M2) Indicator light**  
When on, indicates that the machine is ready for operation.
- M3) Spray control lever**
- M4) Speed regulation handle**  
Allows the user to gradually regulate the machine's advancement speed.
- M5) Indicator**  
Indicates the charge in the electrical battery.
- M6) Alternator**  
When the red indicator is on, it indicates a malfunction in the alternator required for charging the batteries.

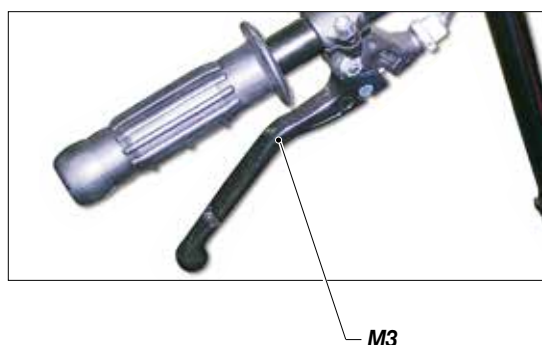
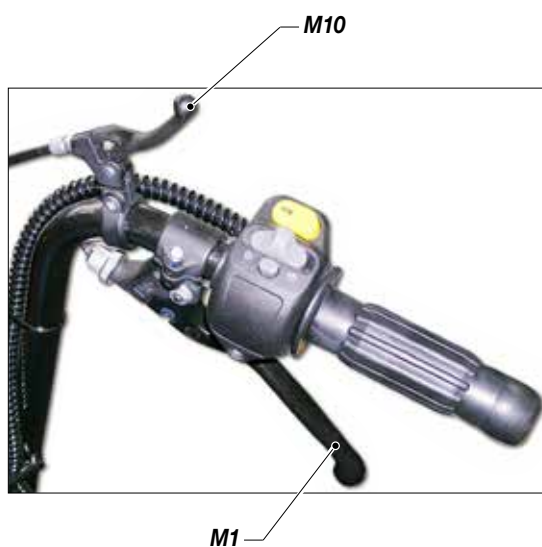



**M7) Direction selector**

Allows the user to select the machine's advancement direction; stops the machine's movement if pressed.

**M8) Speed**

**M9) Light switch**

Activates/deactivates the frontal spotlight (if installed).

**M10) Electric brake release**

When pressed, allows for the machine to be pushed in the event of electrical malfunction or blockage.

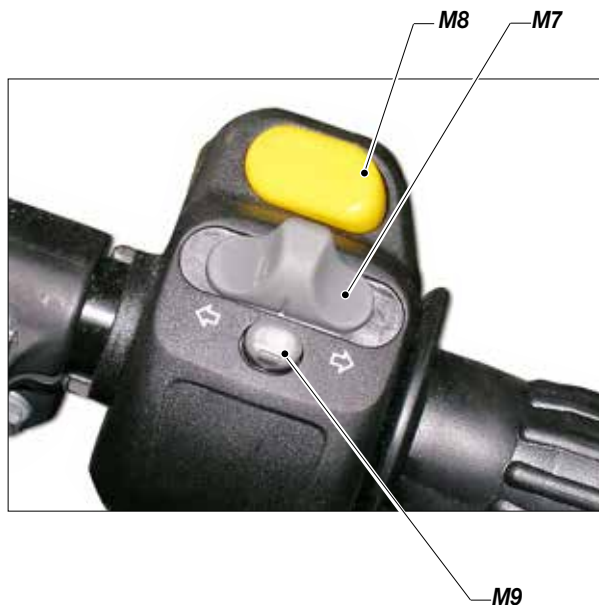
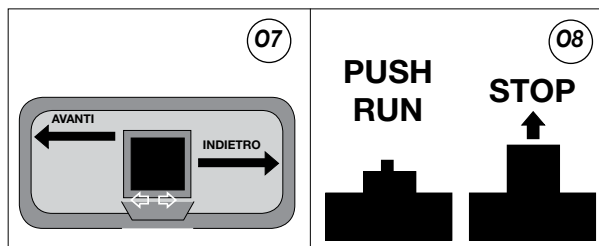



## N CORRECT PROCEDURE OF DECOMPRESSION

- Press the switch (N1) to the OFF position (0) to stop the equipment.

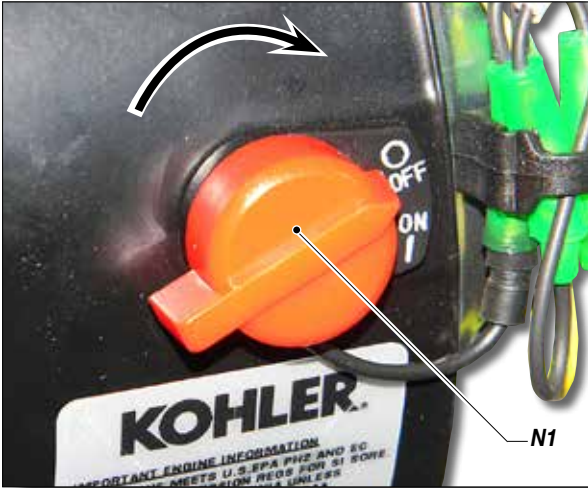

- Point the gun (N4) at the receptacle (N5) used to collect the product and press the trigger to release the pressure. When completed, activate the safety catch again.

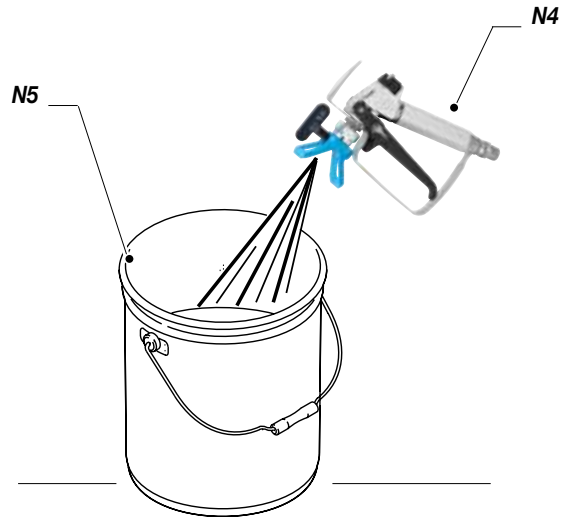

- Minimize pressure level (turning the pressure adjusting knob (N2) clockwise).



- Open the recirculating-safety valve (N6) to release the remaining pressure.



- Unlock the safety clamp (N3).

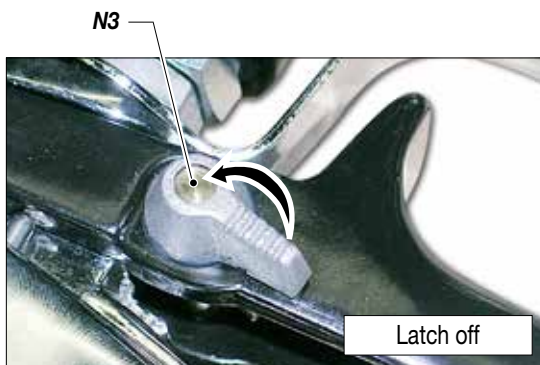

### WARNING:

If the equipment is still under pressure after performing the operations above described because of the nozzle or the flexible hose clogged, proceed as follows:

- Loosen very slowly the gun nozzle.
- Release the clamp.
- Point the gun at the container of the product and press the trigger to release pressure.
- Loosen very slowly the fitting of connection from the flexible hose to the gun.
- Clean or replace the flexible hose and the nozzle.





## **O** PROBLEMS AND SOLUTIONS

Problem	Cause	Solution
<ul style="list-style-type: none"> <li>The equipment does not start</li> </ul>	<ul style="list-style-type: none"> <li>The petrol manifold is closed;</li> <li>Engine is out of gas;</li> <li>Cold engine;</li> <li>Setting valve faulty pressure;</li> <li>The product is solidified inside the pump;</li> <li>Spark plug cable is disconnected or damaged;</li> </ul>	<ul style="list-style-type: none"> <li>Open the petrol manifold;</li> <li>Refill gas tank;</li> <li>Use choke;</li> <li>Verify and replace it, if necessary;</li> <li>Open the drain valve to release pressure in the circuit and stop the machine. Disassemble the pumping group and the pressure transmitter and clean;</li> <li>Connect spark plug cable or replace spark plug;</li> </ul>
<ul style="list-style-type: none"> <li>The equipment does not suck the product</li> </ul>	<ul style="list-style-type: none"> <li>Breakdown of pressure transmitter;</li> <li>The line of material coming out of the pump is already under pressure;</li> <li>The product is solidified inside the pump;</li> </ul>	<ul style="list-style-type: none"> <li>Verify and replace it, if necessary;</li> <li>Open the drain valve to release pressure in the circuit;</li> <li>Open the drain valve to release pressure in the circuit and stop the machine. Disassemble the pumping group and the pressure transmitter and clean;</li> </ul>
<ul style="list-style-type: none"> <li>The equipment does not suck the product</li> </ul>	<ul style="list-style-type: none"> <li>The equipment sucks air;</li> </ul>	<ul style="list-style-type: none"> <li>Check the suction pipe;</li> </ul>
<ul style="list-style-type: none"> <li>The equipment sucks but does not reach the pressure desired</li> </ul>	<ul style="list-style-type: none"> <li>Lack of product;</li> <li>The equipment sucks air;</li> <li>The drain valve is open;</li> <li>Suction or delivery valve dirty;</li> </ul>	<ul style="list-style-type: none"> <li>Add the product;</li> <li>Check the suction pipe;</li> <li>Close the drain valve;</li> <li>Disassemble the colour group;</li> </ul>
<ul style="list-style-type: none"> <li>When pressing the trigger, the pressure lowers considerably</li> </ul>	<ul style="list-style-type: none"> <li>Nozzle too big or worn;</li> <li>The product is too dense;</li> <li>The filter of the gun-butt is too fine;</li> </ul>	<ul style="list-style-type: none"> <li>Replace it with a smaller one;</li> <li>Dilute the product, if possible;</li> <li>Replace it with a larger-mesh filter;</li> </ul>
<ul style="list-style-type: none"> <li>The pressure is normal but the product is not atomized.</li> </ul>	<ul style="list-style-type: none"> <li>The nozzle is partially clogged;</li> <li>The product is too dense;</li> <li>The filter of the gun-butt is too fine;</li> </ul>	<ul style="list-style-type: none"> <li>Clean or replace it;</li> <li>Dilute the product, if possible;</li> <li>Replace it with a larger-mesh filter;</li> </ul>
<ul style="list-style-type: none"> <li>The atomization is imperfect</li> </ul>	<ul style="list-style-type: none"> <li>The nozzle is worn;</li> </ul>	<ul style="list-style-type: none"> <li>Replace it;</li> </ul>



Always release the air compressed supply and unload the plant pressure before performing any check or replacement of pump parts (see “correct procedure of decompression”).

**Intentionally blank page**



# SPARE PARTS

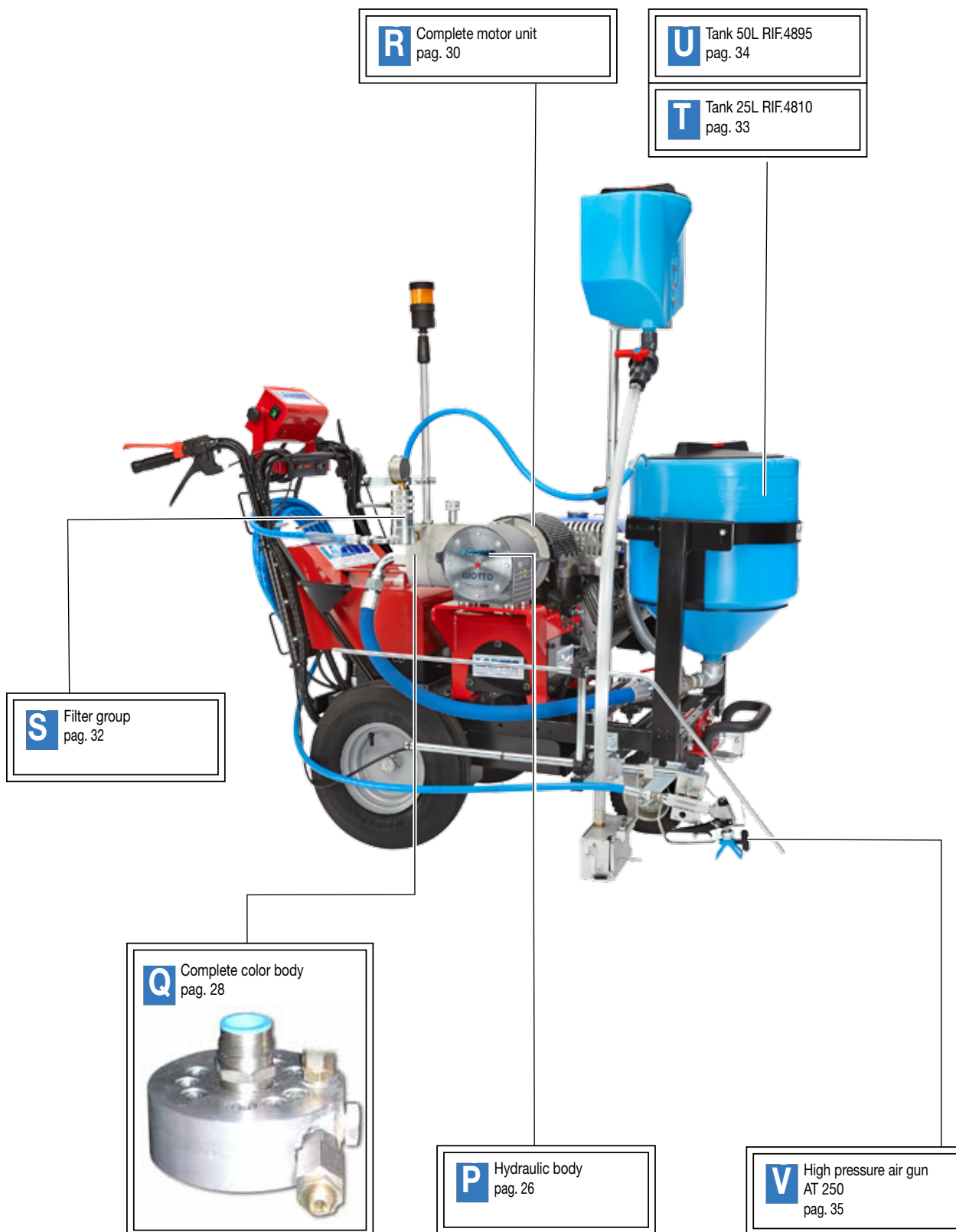



# P HYDRAULIC BODY

**WARNING:** Always indicate code and quantity for each part required.

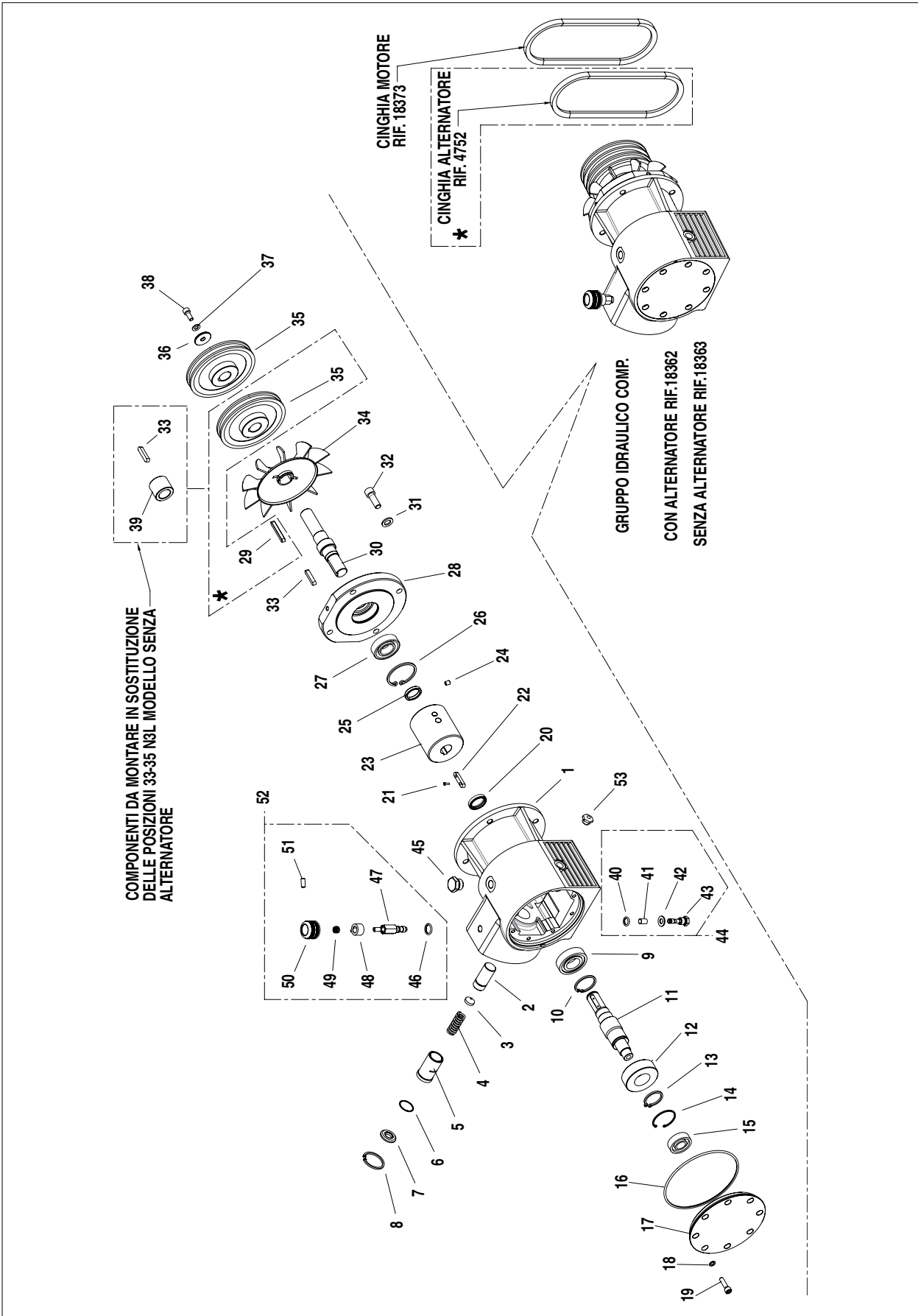





Pos.	Code	Description	Pos.	Code	Description
1	12455	Hydraulic body	28	18314	Flange
2	12456	Hydraulic piston	29	31166	Tab
3	82019G	Backstop for spring	30	18328	Shaft
4	82021	Spring	31	95114	Washer ø 12
5	82017	Cylinder liner	32	18171	Screw M 12x25
6	82022	OR 2118	33	81014	Tab
7	82023	Spring seat	34	18342	Impeller
8	82024	Elastic ring	35	18320	Pulley
9	31125	Bearing	36	95153	Washer ø 9x36
10	81020	Elastic ring	37	34009	Washer ø8
11	18197	Shaft	38	96031	Screw M 8x25
12	12457	Bearing	39	18384	Spacer
13	12467	Elastic ring	40	32012	OR 2021
14	12466	Elastic ring	41	258	Filter
15	12465	Bearing	42	32010	Washer 18x14.4x1.5
16	12464	OR 3625	43	12461	Oil filter body
17	12459	Cover	44	12475	Screw oil filter
18	12462	Washer	45	82005	Oil cap
19	81032	Vite m8x35	46	32014	OR 9.8x1.5
20	31128	Corteco	47	32155	Valve body
21	9308	Screw m3x8 uni 5931	48	32016	Safety stop
22	18919	Spline uni 6604-a	49	32017/2	Spring
23	18327	Handwheel	50	32017/1	Handle
24	18142	Dowel M 8x10 tc	51	32017/1C	Dowel M 5x12
25	18321	Spacer	52	32150	Pressure valve
26	18341	Elastic ring	53	95214	Level oil cap
27	42255	Bearing			



## Q COMPLETE COLOUR BODY

**WARNING:** Always indicate code and quantity for each part required.

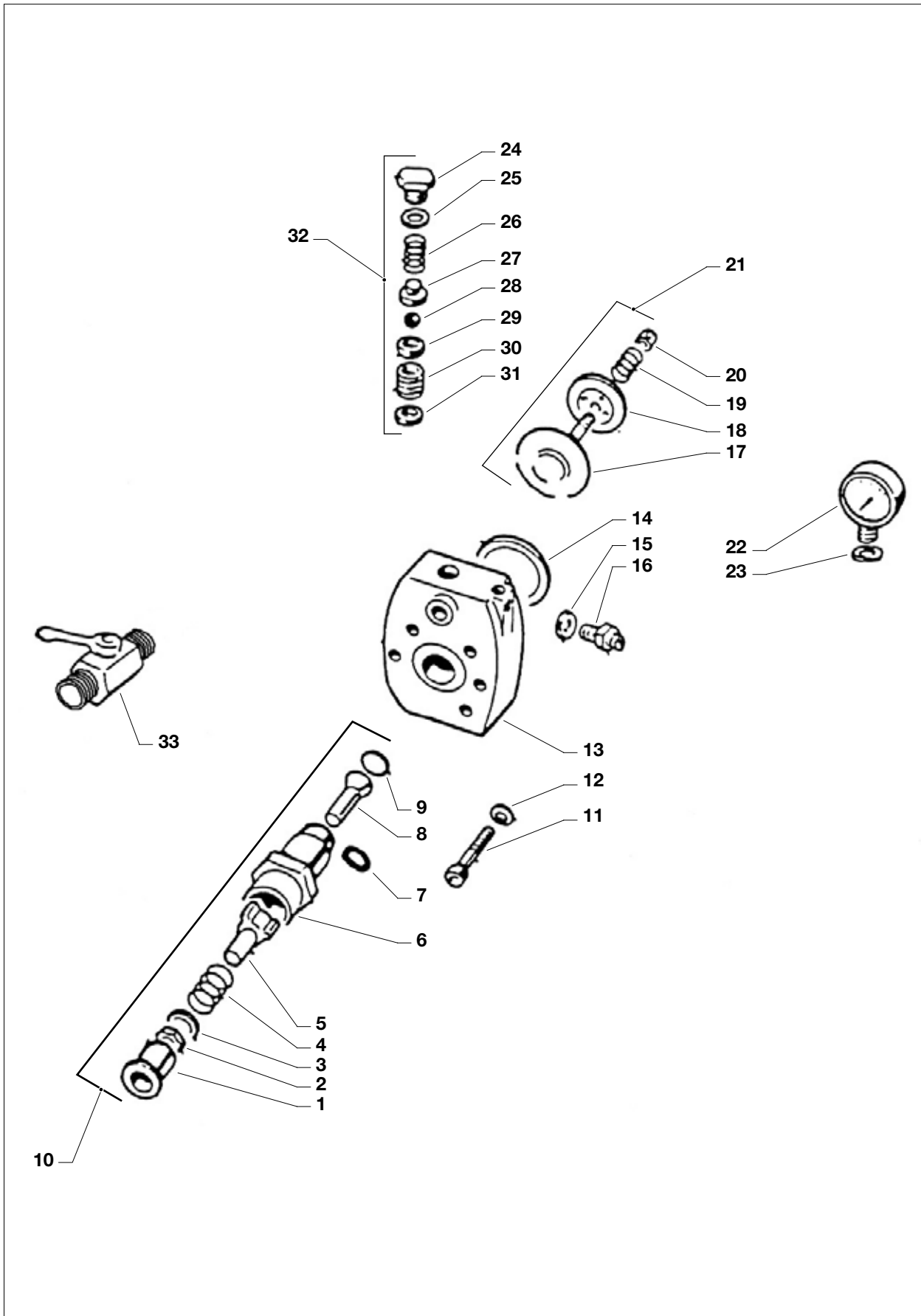



Pos.	Code	Description	Pos.	Code	Description
-	83000	Complete colour body	17	83002/1	Diaphragm
1	96099	Cylinder liner	18	83002/2	Oil distributor
2	33024	Self-tightening nut	19	83002/3	Spring
3	53006/1	Washer	20	83002/4	Sealing block
4	33022	Spring	21	83002	Complete diaphragm
5	33021	Shutter guide	22	33008	Manometer
6	33020	Suction valve body	23	33009	Washer
7	33020/1	Ball seat	24	33032	Plug
8	33019	Conical shutter	25	33031	Gasket
9	33018	Gasket	26	53006	Spring
10	33017	Complete suction valve	27	33029	Spring seat
11	83004	Screw	28	33028	Ball
12	33005	Washer	29	33027/1	Union for ball seat
13	83001	Colour body fusion	30	33027/2	Ball seat
14	83003	Diaphragm insert	31	33026	Gasket
15	33007	Washer	32	83033	Complete valve exhaust
16	33006	Feed tube union	33	33013/2	Cock



# R COMPLETE MOTOR UNIT

**WARNING:** Always indicate code and quantity for each part required.

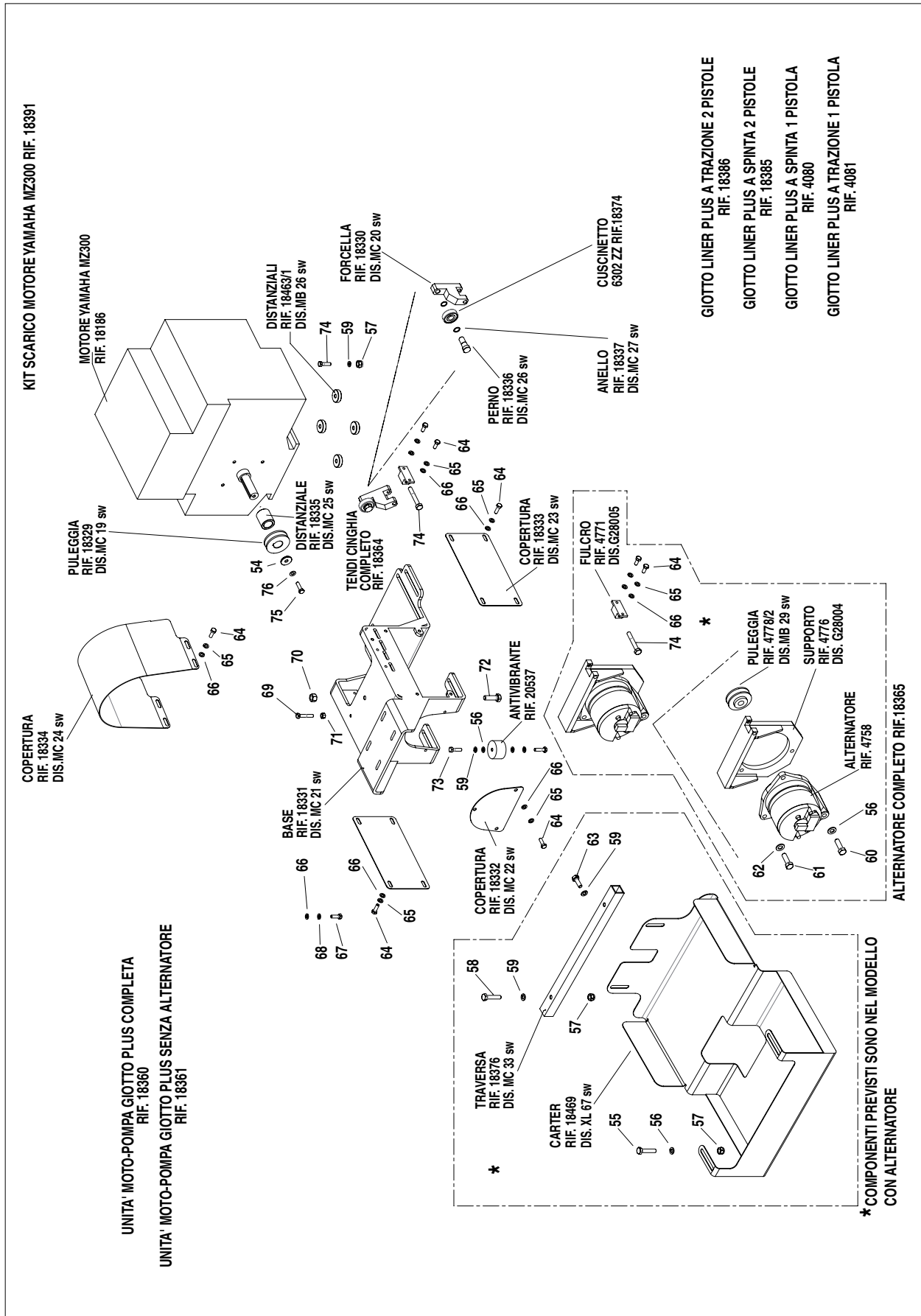

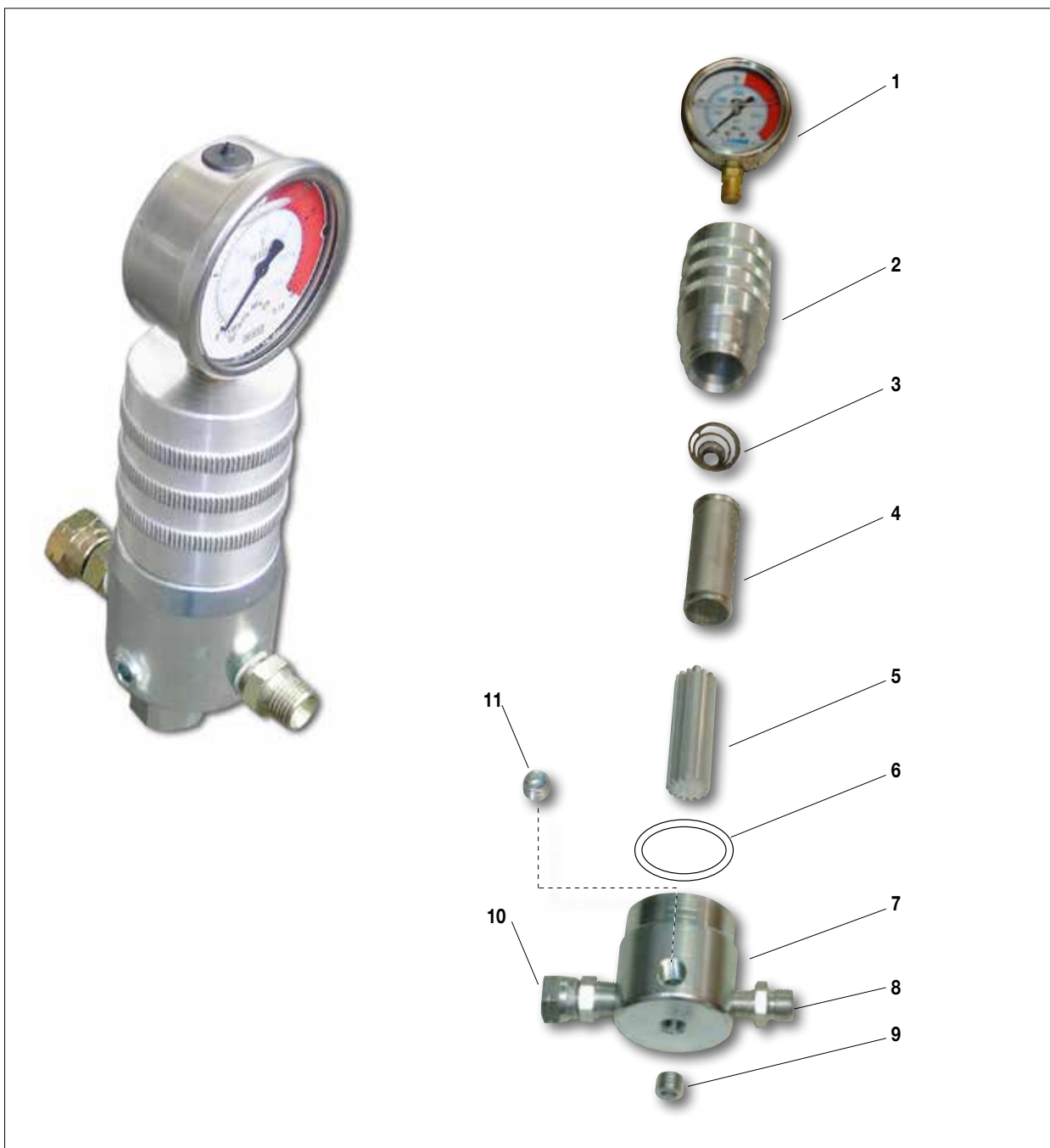

Pos.	Code	Description	Pos.	Code	Description
54	95153	Washer ø9x36	66	32024	Washer ø 8
55	69107	Screw M10x80	67	96031	Screw M8x25
56	95096	Washer ø10	68	96030	Washer grower ø 8
57	96080	Nut M10	69	4436	Screw M8x70
58	20560	Screw M10x60	70	96893	Nut M12
59	81033	Washer ø10	71	52017	Nut M8
60	4440	Screw M10x100	72	5755	Screw M12x120
61	95083	Screw M12x40	73	6130	Screw M10x20
62	95066	Washer ø12	74	20560	Screw TE UNI5737 M10x60
63	6130	Screw M10x20	75	18192	Screw TE 3/8-24
64	32004	Screw M8x16	76	3305	Washer schnor ø 10
65	34009	Washer schnor ø 8			

**S FILTER GROUP REF. 16200****WARNING:** Always indicate code and quantity for each part required.

Pos.	Code	Description	Q.tà	Pos.	Code	Description	Q.tà
1	33008	Manometer 0-400 bar	1	6	96203	Gasket	1
2	16201	Filter tank	1	7	96204	Filter Base	1
3	96020	Spring	1	8	96026	Union	1
4	16205	Standard sieve 60	1	9	96205	Dowel	1
	16204	Standard sieve 100	1	10	3279	Articulated joint 3/8" Gas con.	1
	16203	Standard sieve 200	1	11	96205	Dowel	1
5	16202	Sieve support	1				



## T COMPLETE 25L TANK REF. 4810

**WARNING:** Always indicate code and quantity for each part required.

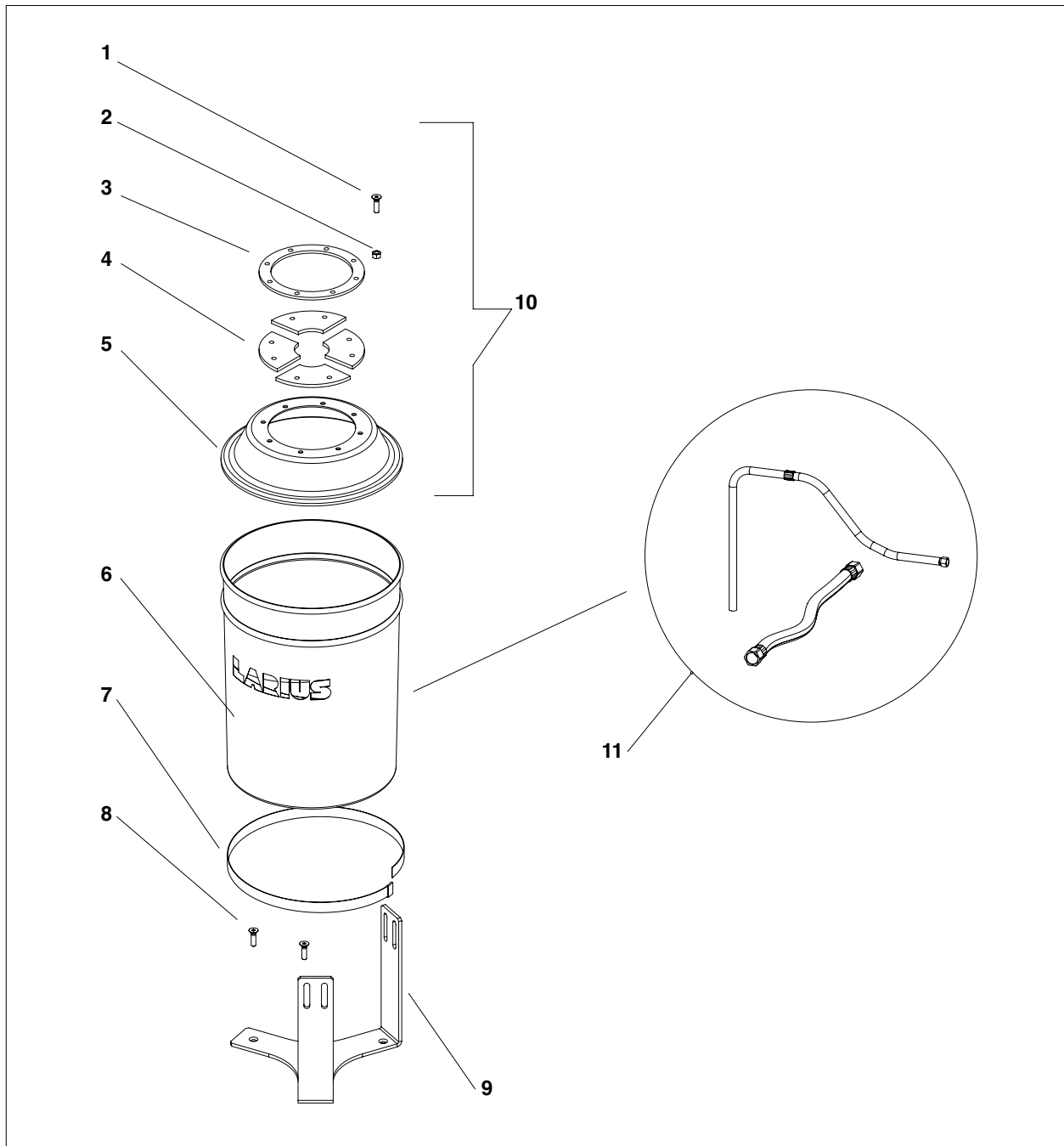

Pos.	Code	Description	Pos.	Code	Description
-	4890	Serbatoio 25L completo	7	4274	Cinghia
1	4314	Vite	8	69014	Vite
2	52017	Dado	9	4250	Base
3	4308	Anello	10	4111	Coperchio completo
4	4309	Gomma	11	16675	Sistema completo aspirazione+mandata
5	4109	Coperchio			
6	4064	Serbatoio 25L			



# U COMPLETE 50L TANK REF. 4895

**WARNING:** Always indicate code and quantity for each part required.

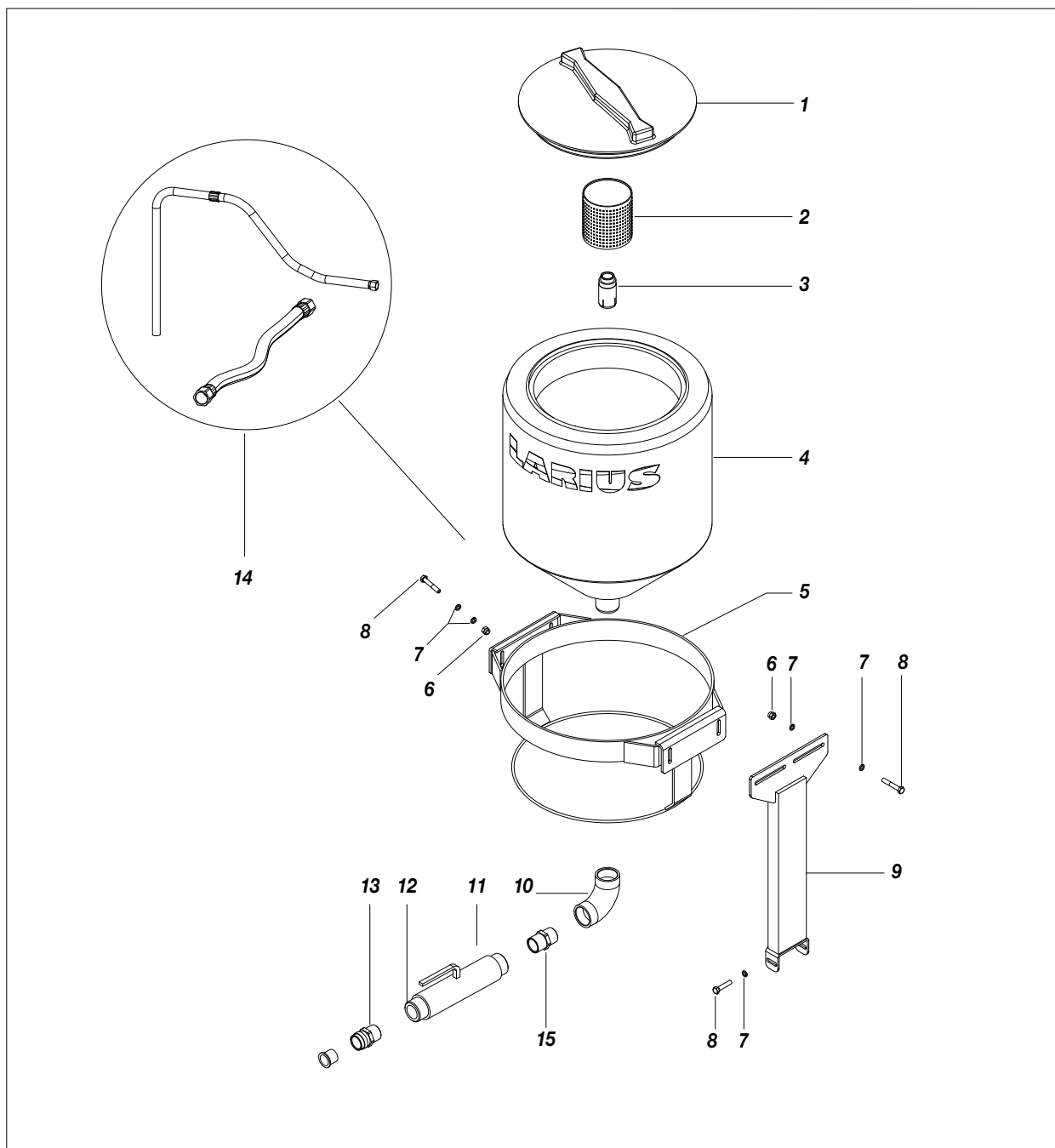

Pos.	Code	Description	Pos.	Code	Description
1	18249/1	Cover	9	4894	Support
2	85014	Filter	10	20833	Elbow
3	18231	Support	11	34107	Adaptor
4	18249	50L Tank	12	95032	Union
5	18246	Support	13	96099	Seal
6	3637	Nut	14	4834	Complete suction+delivery system
7	96030	Washer	15	8375	Union
8	901568	Screw			





## V HIGH PRESSURE GUN AT 250

**WARNING:** Always indicate code and quantity for each part required.

**Ref. 11210**  
**Mirò Small Liner**  
**complete spraying gun**

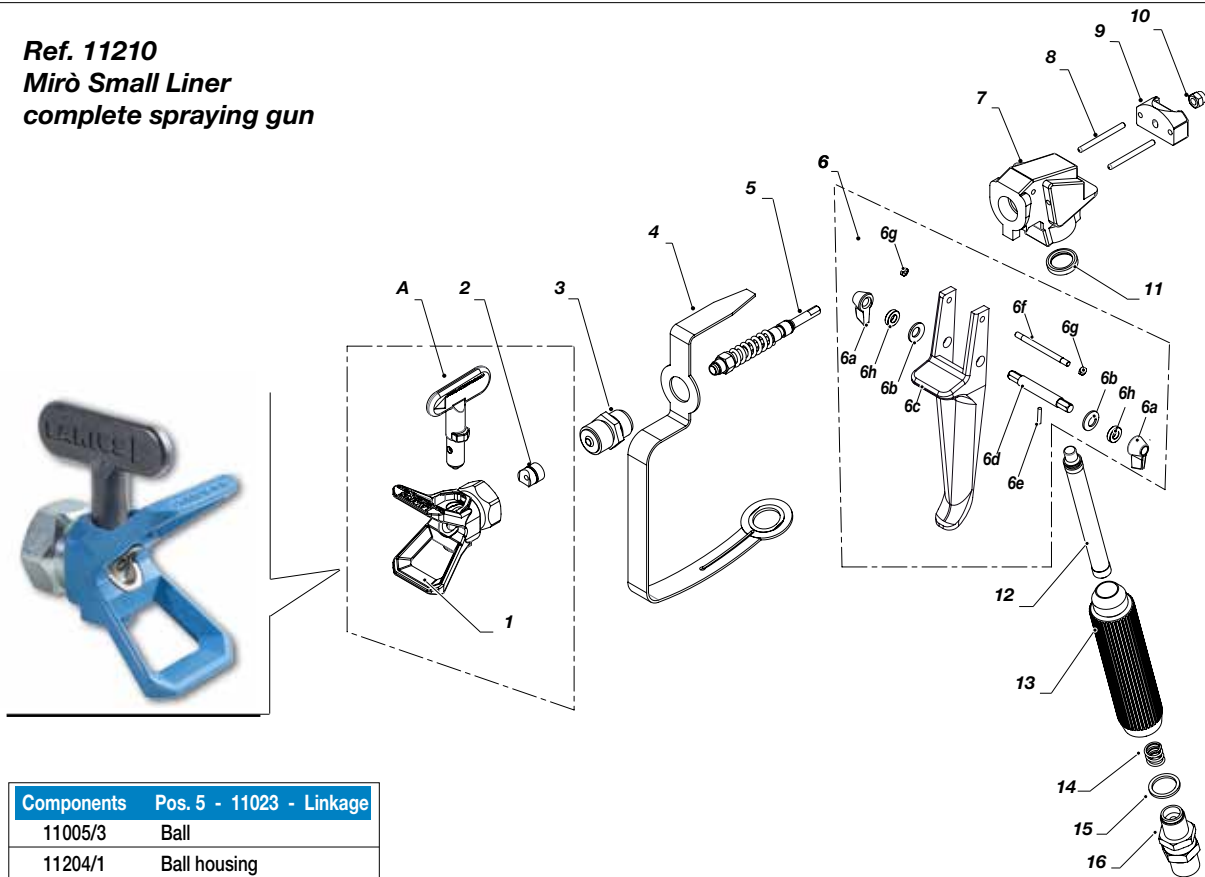

Components	Pos. 5 - 11023 - Linkage
11005/3	Ball
11204/1	Ball housing
11205/2	Spring
11205/4	Linkage
11205/5	Sleeve
11205/6	Ring sleeve
11205/7	Bushing

Pos.	Code	Description	Pos.	Code	Description
A	4833	Fast Clean Small Liner kit	6g	11027	Nut M3
1	18270	Body Super Fast Clean	6h	11016	Washer
2	18280	Gasket Super Fast Clean	7	11206	Gun body
3	11004	Sleeve	8	11207	Spinet
4	11006 + 11032	Safety for hand + 3 screws TSP 3x8	9	11208	Plate
5	11203	Complete linkage	10	11209	Self-locking nut M5
6	11008	Trigger gun	11	11020	Copper gasket
6a	11010	Safety lever	12	-	Filter
6b	11011	Brake washer	13	11018	Handgrip
6c	11009	Trigger	14	11017	Spring
6d	11012	Pin	15	32010	Copper gasket
6e	11013	Pin	16	11015	Articulated joints M16x1,5
6f	11034/1	Pin		11155	Articulated joints 1/4"

**W ACCESSORIES****WARNING:** Always indicate code and quantity for each part required.**Art. 11250:**  
AT 250 1/4"**Art. 11200:**  
AT 250 M16x1,5**Art. 16802:** 30 MESH FILTER**Art. 270:** 100 MESH FILTER  
**Art. 271:** 60 MESH FILTER**PISTON GUNSTOCK  
FILTERS****Art. 11039:** Green (30M)  
**Art. 11038:** White (60M)  
**Art. 11037:** Yellow (100M)  
**Art. 11019:** Red (200M)**SUCTION BELL KIT****Art. 35004:** FILTER BELL  
**Art. 35006:** FILTER 100 MESH  
**Art. 35007:** FILTER 50 MESH  
**Art. 35007/1:** FILTER 30 MESH**HIGH PRESSURE HOSE 3/8"**- M16x1,5  
max pressure 425 bar  
**Art. 18063:** 7,5 mt  
**Art. 18064:** 10 mt  
**Art. 18065:** 15 mt**Art. 147:**  
HIGH PRESSURE  
MANOMETER M16x1,5**Art. 150:** HIGH PRESSURE  
MANOMETER  
GJ 1/4"**ANTISTATIC HOSE 3/16"**- M16x1,5  
max pressure 210 bar  
**Art. 6164:** 5 mt  
**Art. 55050:** 7,5 mt  
**Art. 35018:** 10 mt



**Art. 4405:**  
GLASS BEADS  
DISPENSER



**ANTISTATIC HOSE 1/4"**  
- M16x1,5  
Press. max. 250 bar  
**Art. 35013:** 5 mt  
**Art. 35014:** 7,5 mt  
**Art. 35017:** 10 mt  
**Art. 18026:** 15 mt



**ELECTRIC MIXERS:**  
**Art. 217550:** MX 850 Power 850W  
**Art. 217560:** MX 1100 Power 1080W  
**Art. 217570:** MX 1100E Power 1080W



**GUN EXTENSION**  
**Art. 153:** cm 30  
**Art. 153:** cm 40  
**Art. 155:** cm 60  
**Art. 158:** cm 80  
**Art. 156:** cm 100



PLA 1/4" + BASE

**SUPER FAST-CLEAN**

**Art. K11420-K11425-K11430:**

cm 130-180-240

PLA M16x1,5 + BASE

**SUPER FAST-CLEAN**

**Art. K11421-K11426-K11431:**

cm 130-180-240



**Art. 16780:**

**TELESCOPIC PAINT ROLLER**

complete with:

n. 1 Roller with extra-long fiber

n. 1 Roller with long fiber

n. 1 Roller with medium fiber

Flexible hose mt. 2 3/16 " M16x1,5



**TOP - SPRAYING CLEAN**



**TOP-SPRAYING CLEAN TIP**

Code tip	
TSC 7-20	TSC 19-20
TSC 7-40	TSC 19-40
TSC 9-20	TSC 19-60
TSC 9-40	TSC 21-20
TSC 11-20	TSC 21-40
TSC 11-40	TSC 21-60
TSC 13-20	TSC 23-20
TSC 13-40	TSC 23-40
TSC 13-60	TSC 23-60
TSC 15-20	TSC 27-20
TSC 15-40	TSC 27-40
TSC 15-60	TSC 27-60
TSC 17-20	TSC 31-40
TSC 17-40	TSC 31-60
TSC 17-60	



**Art. 18280: GASKET**



**Art. 18270: SUPER FAST-CLEAN**  
base UE 11/16x16

**SUPER FAST - CLEAN**



**SUPER FAST-CLEAN TIP**

Code tip		
SFC07-20	SFC19-60	SFC29-80
SFC07-40	SFC21-20	SFC31-40
SFC09-20	SFC21-40	SFC31-60
SFC09-40	SFC21-60	SFC31-80
SFC11-20	SFC23-20	SFC33-40
SFC11-40	SFC23-40	SFC33-60
SFC13-20	SFC23-60	SFC33-80
SFC13-40	SFC25-20	SFC39-40
SFC13-60	SFC25-40	SFC39-60
SFC15-20	SFC25-60	SFC39-80
SFC15-40	SFC27-20	SFC43-40
SFC15-60	SFC27-40	SFC43-60
SFC17-20	SFC27-60	SFC43-80
SFC17-40	SFC27-80	SFC51-40
SFC17-60	SFC29-20	SFC51-60
SFC19-20	SFC29-40	SFC51-80
SFC19-40	SFC29-60	



**Art. 18280: GASKET**



**Art. 18270: SUPER FAST-CLEAN** base UE 11/16x16

**Intentionally blank page**



## CE DECLARATION OF CONFORMITY



### Company



**LARIUS srl**  
Via Antonio Stoppani 21 - 23801 Calolziocorte (LC) ITALY  
**Tel:** +39 0341 621152  
**Fax:** +39 0341 621243  
**E-mail:** larius@larius.com

Declares under his owns responsibility that the product:

### **GIOTTO LINER PLUS** Airless line striper with diaphragm pump

complies with the directives:

- EC Directive 2006/42 Machinery Directive
- EU Directive 2014/30 Electromagnetic Compatibility (EMC)
- EU Directive 2014/35 Low Voltage (LVD)

furthermore to the  
harmonized standards:

- UNI EN ISO 12100-1/-2  
Machinery safety, basic concepts, general principles of design. Basic terminology, methodology. Technical principles.

This declaration relates exclusively to the product in the state in which it was placed on the market, and excludes components or modifications which are added or carried out subsequently by end user.

Calolziocorte, 31 August 2020  
Location / Date

Signature

**Pierangelo Castagna**  
Managing Director



**LARIUS srl**

Via Antonio Stoppani 21 - 23801 Calolziocorte (LC) ITALY  
TEL. +39 0341 621152 - Fax +39 0341 621243 - [larius@larius.com](mailto:larius@larius.com)

[www.larius.com](http://www.larius.com)

