



CBU control panel (Mod-Bus transmission Unit)

New design, latest technology, big display and soft touch buttons for quick menu navigation, start and stop procedure, IP54 protection grade. Very compact MASTER CBU 93x93mm (3.66x3.66 in). CBU has many functions for easy monitoring of the generator:

- ON/OFF/START/STOP/MENU controls.
- Digital hour-meter, Main voltage, Generator Battery voltage, external battery pack voltage, Frequency, Service time, Event list of last 10 alarms and time.
- 13 different alarms icons displayed.
- 485 Mod-Bus connector for monitoring generator by boat main control monitor.

Engine

- Easy access in case of maintenance of feeding system, lubrication system, sea/water pump and air filter.
- Safety stop in case of low oil pressure.
- Safety stop in case high engine temperature or exhaust gas temperature.
- Oil filter and fuel filter easy to replace.
- Quick access to seawater pump.

Alternator

- Permanent magnet alternator (PMG)

Soundproof cabin

A new project cabin composed by painted marine aluminum panels. It combines an innovative design and a very high resistance to external agents.

Thanks to this design, soundproof cabin has a very limited weight, and an easy accessibility for maintenance service, also if installed in narrow sites.

THE INTERCOOLER W/A

Assures the perfect functioning of the generator independently of the external ambient temperature, therefore the alternator and the engine will work at ideal temperature optimizing the performance and reliability of the gen-set.

Engine

Model	Kubota D902
Type	Diesel 4 stroke
Cylinders (nr.)	3
Cylinder block material	Cast iron
Bore (mm - in.)	72 - 2,8
Stroke (mm - in.)	73,6 - 2,9
Displacement (cc - cu.in.)	898 - 35,4
Power (hp - kW)	18 - 13,2
Rated rpm	from 2100 to 3150
Combustion system	Indirect
Engine head material	Cast iron
Speed governor	Electronic by actuator
Lubrication system	Forced
Oil sump capacity (L - qt.)	3,8 - 4,0
Engine stop system	Stop solenoid
Fuel pump	Electric
Fuel pump discharge (cm - in.)	70 - 27,6
Starting battery (Ah-V)	45 - 12
Battery charger (W-V)	150 - 12
Starter (kW-V)	1,2 - 12
Max. inclination	30°
Water pump flow (L/min - gal/min)	22 - 5,81

Alternator

Type	PMG
Cooling	Air/water (Intercooler W/A)
Voltage (V)	115 / 240
Frequency (Hz)	50 / 60
Continuous power (kW)	12
Power factor (cos ϕ)	1
Insulating class	H
Voltage stability	$\pm 1\%$
Frequency stability	$\pm 1\%$

Cooling system

The cooling of the engine is based on a coolant closed circuit. The system is composed by seawater/coolant heat exchanger. Air inside the canopy is cooled through seawater/air heat exchanger. This system makes cooling of alternator more effective and achieve optimal temperature for best performance and reliability of the generating set, independent from allocation room temperature.

VS 12.6 50/60 Hz

50Hz / 60Hz

Dimensions (Leng. x Width x Height)	730 x 468 x 555	mm
	28,7 x 18,4 x 21,9	in.
Weight	192 - 423	kg - lb
Noise level emission	54 dBA @ 7mt	

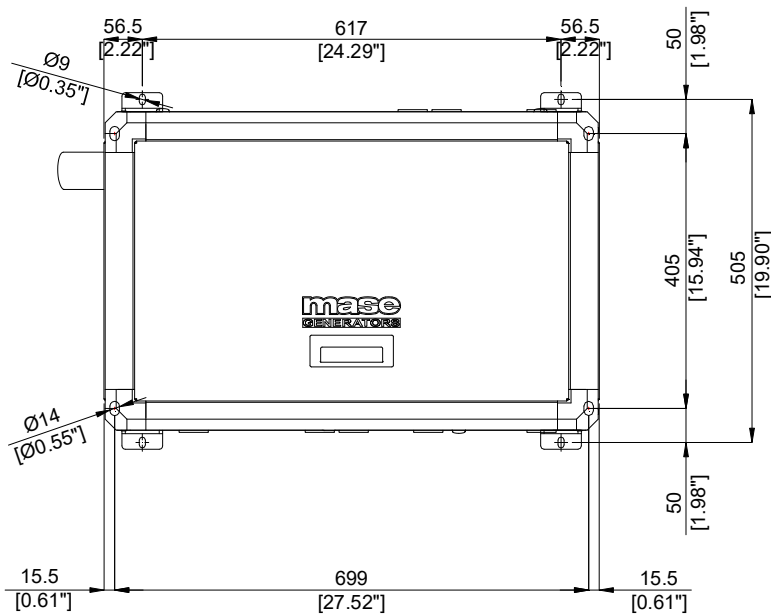
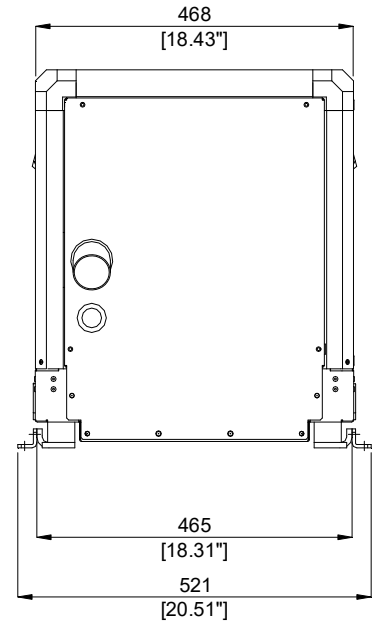
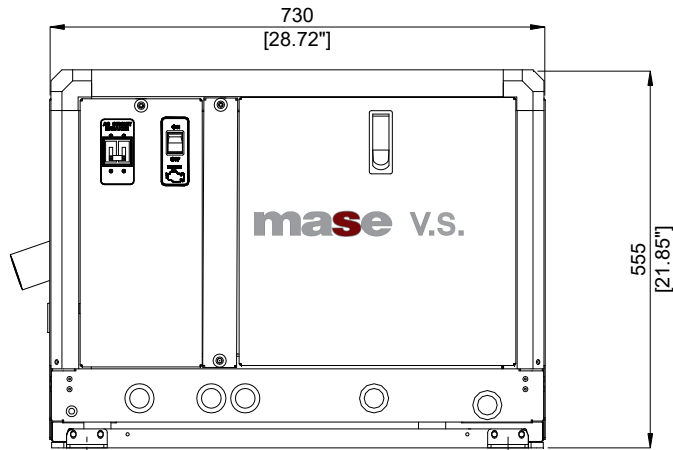

FITTINGS (optional)

- EXHAUST COMPONENTS KIT
- SIPHON BREAK
- WATER-GAS SEPARATOR KIT
- STARTING REMOTE CONTROL PANEL WITH A SHIELD CONNECTING CABLE 10 Mt. (32.8 ft) LONG OR
- SLAVE CBU CONTROL PANEL WITH A SHIELD CONNECTING CABLE 10 Mt. (32.8 ft) LONG

*This drawing is only a reference and is not indicated for the installation. For more information, you may contact your local dealer or **mase generators S.p.A.***

***mase generators S.p.A.** reserves the right to change the design or specifications without notice and without any obligations or liability whatsoever. For more information, you may contact your local **mase** dealer.*

Dealer:

mase
GENERATORS

MASE GENERATORS S.p.A. Via Tortona, 345
47522 Cesena (FC) Italy
Tel.+39-0547-354311 Fax.+39-0547-317555
Email : mase@masegenerators.com