

Contents

Contents	2
Important Notice	3
1. SAFETY INSTRUCTIONS	4
1.1 General.....	4
1.2 Safety Instructions	5
2. DEVICE DESCRIPTION	6
2.1 Introduction	6
2.2 Area of application	7
2.3 Hardware	8
2.3.1 Control elements and interfaces	8
2.3.2 Device connections: power and high voltage.....	10
2.3.3 Device connections: control signals and interfaces.....	11
2.4 Software	13
2.4.1 Operating modes.....	13
3. Description of the functionality.....	14
3.1 Soft Start.....	14
3.2 Droop Compensation	14
3.3 'Keep alive'.....	15
3.4 Limiters	16
3.4.1 V/f Limiter	16
3.4.2 Minimum excitation current.....	16
3.4.3 Maximum excitation current.....	17
3.4.4 Minimum capability	17
3.4.5 Massima capability.....	18
4. References and Regulations.....	19
4.1 Field Current Regulation (FCR).....	20
4.2 Automatic voltage regulator (AVR)	20
4.3 Automatic Power Factor regulation (PF)	21
4.4 Automatic reactive power regulation (VAR)	21
4.5 Digital reference adjust by calibrator (U/Down).....	22
4.6 Digital reference adjust by analog (Pot/An. In)	22
5. OPERATOR INTERFACE	23
5.1 Control keypad and display	23
5.2 Navigating the menus.....	23
5.3 Menu	25
5.3.1 Menu d – Display.....	25
5.3.2 Menu r – References and Regulators.....	25
5.3.3 Menu I – Inputs and outputs.....	26
5.3.4 Menu P – Parameters.....	26
6. MAINTENANCE AND FAULTS	27
6.1 Safety regulations	27
6.2 Maintenance	27
6.3 Trouble shooting	27
6.4 Repair.....	28
7. General Data.....	29

Important Notice

Our experience has shown that, if the information and recommendations contained in this Operating Instructions are observed, the best possible reliability of our products is assured.

The data contained herein purports solely to describe the product and it is not a warranty of performance or characteristics. It is with the best interests of our customers in mind that we constantly strive to improve our products and keep them abreast of advances in technology. This may, however, lead to discrepancies between a product and its "Technical Description" or "Operating Instructions".

This document has been carefully prepared and reviewed, however should in spite of this the reader find an error, he is requested to inform us at his earliest convenience.

It is scarcely possible for the operating instructions for technical equipment to cover every eventuality, which can occur in practice. We would therefore request you to notify us or our agent in the case of all unusual behavior that does not appear to be covered by these operating instructions.

It is pointed out that all local regulations must be observed when connecting and commissioning this equipment in addition to these operating instructions.

We cannot accept any responsibility for damage incurred as a result of mishandling the equipment regardless of whether particular reference is made in these operating instructions or not.

We lay particular stress on the fact that only genuine spare parts should be used for replacements.

All rights with respect to this document, including applications for patent and registration of other industrial property rights, are reserved. Unauthorized use, in particular reproduction or making available to third parties, is prohibited.

1. SAFETY INSTRUCTIONS

1.1 General

The safety instructions shall be followed during installation, commissioning, operation and maintenance of the excitation system. Read all instructions carefully before operating the device and keep this manual for future reference.

Required Qualification

Personnel involved in installation work and commissioning of the S2014 must be familiar, specially instructed and informed about the residual danger areas according to the regulations currently in force.

Operating personnel is not permitted to work at the control system.

Specially instructed personnel must only carry out maintenance and repair work.



The maintenance personnel must be informed about the emergency shutdown measures and must be capable of turning off the system in case of emergency.

The maintenance personnel must be familiar with the accident prevention measures at their workplace and must be instructed in first aid and fire fighting.

It is the owner's responsibility to ensure that each person involved in the installation and commissioning of the S2014 has received the appropriate training or instructions and has thoroughly read and clearly understood the safety instructions in this chapter.

1.2 Safety Instructions

The safety instructions always appear at the beginning of each chapter and/or precede any instruction in the context where a potentially dangerous situation may appear. The safety instructions are divided into five categories and emphasized by the use of the following layout and safety signs:

	<p>DANGER!</p> <p>This symbol indicates an imminent danger resulting from mechanical forces or high voltage. A non-observance leads to life-threatening physical injury or death.</p>
	<p>WARNING!</p> <p>This symbol indicates a dangerous situation. A non-observance may lead to bad or life-threatening physical injury or death.</p>
	<p>CAUTION!</p> <p>This symbol indicates a dangerous situation. A non-observance may lead to physical injury or cause damage to the converter.</p>
	<p>NOTICE!</p> <p>This symbol emphasizes important information. A non-observance may cause damage to the converter or to objects close to it.</p>
	<p>IMPORTANT!</p> <p>This symbol indicates useful information. Not to be used to indicate dangerous situations.</p>

2. DEVICE DESCRIPTION

2.1 Introduction

S2014 is an automatic voltage regulator of the latest design for controls alternators excitation. The unit contains the most advanced microprocessor technology together with SCR semiconductor technology (Silicon Controlled Rectifier).

A practical and simple-to-operate panel on the unit is used for all control operations. In addition, user friendly software facilitates commissioning allows optimization of operation.

The mechanical construction is compact and robust.

2.2 Area of application

This advanced-design automatic voltage regulator is used for the excitation of synchronous machines. This unit is only suitable for this one area of application.

The regulator can also be switched over to function as a automatic voltage regulator, power factor or reactive power regulation.

SM= Synchronous Machine

E = Exciter

PMG = Permanent-Magnet-Generator

Generator excitation from generator output

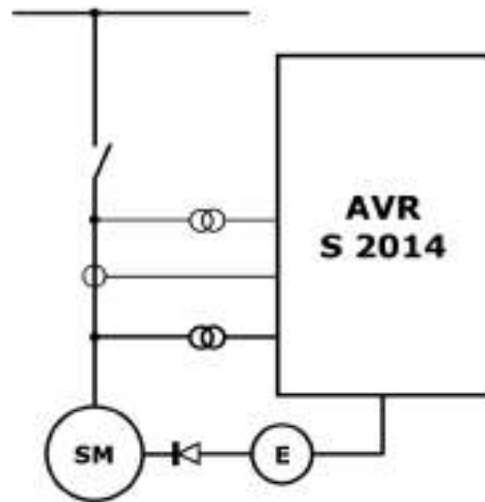

Generator excitation with PMG or external supply.

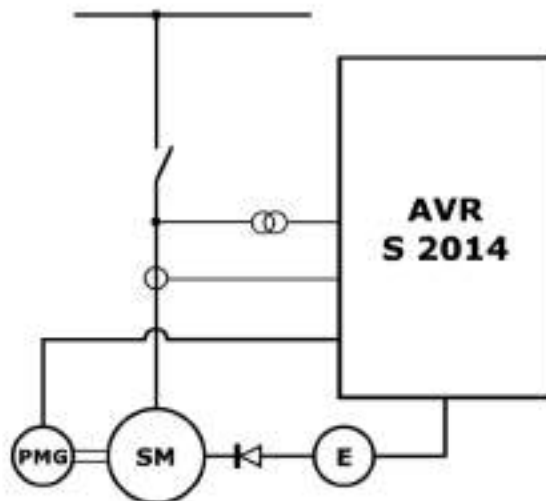

Replacement of voltage regulators for generators with direct-current excitation machines.

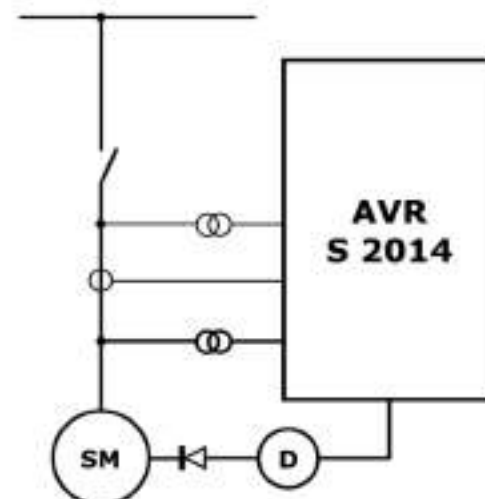

2.3 Hardware

Structure:

The device is built into a plastic casing, depending on the nominal output current some models have an aluminum base for cooling.

The connection terminals are integrated on top of the circuit boards.

Power electronics:

The power part is fitted with SCR semiconductors.

The average value of the output voltage is always positive. The output is protected against short-circuit by a fuse.

Control elements:

The operating keys and the display are located on the circuit board.

The connector of the communication port it is located on the regulator.

Installation:

The site of installation must be dry and free of dust.

Mounting:

The regulator must be installed inside the machine or inside the control panel in order to be protected against accidental contacts. For fastening the regulator, 4 MA through-screws should be tightened with self-locking nuts in two corners holes.

It is recommended to bind the regulator back on a metal plate for better dissipation.

Connection diagram:

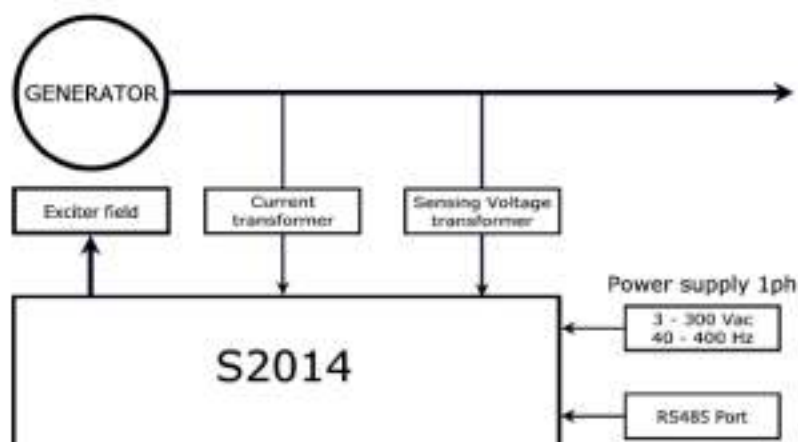

2.3.1 Control elements and interfaces

Carrying out settings on the unit

The displays and the four keys are sufficient to allow complete operation.

All settings can be carried out directly on the unit without additional equipment.

- Configuration of inputs and outputs;
- Parameter setting;
- Display of important measuring values.

Interface with PC

Parameter setting and also optimization is possible using the user-friendly software *S2014 Config* for Microsoft Windows.

Connection cable with RS-485 Half-Duplex (two wire)

- Configuration of inputs and outputs;
- Parameter setting;
- Display of important measuring values;
- Parameter File upload or download.

Note: The interface is not isolated from the power supply

In order to connect with a pc or other devices an interface isolator must be used



Terminal blocks

Overview of the device connections

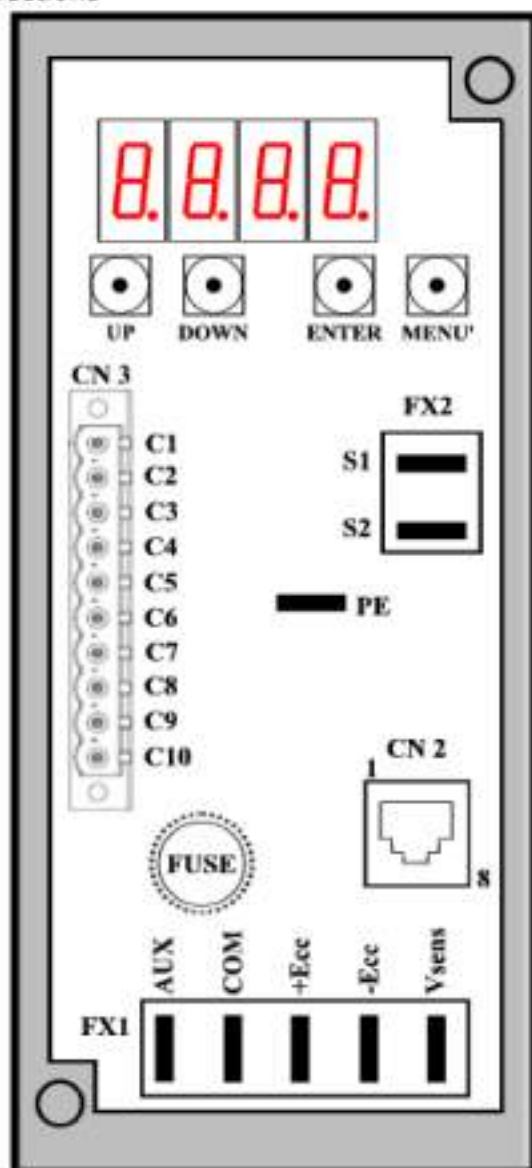

CN2 – RS 485 Serial Interface		CN3 – Control connections	
1	GND	C1	Common
2	GND	C2	Up reference adjust
3	--RESERVED--	C3	Down reference adjust
4	LINK -	C4	Feedback Parallel
5	LINK +	C5	±5V reference adjust
6	--RESERVED--	C6	Potentiometer reference adjust 1Kohm
7	--RESERVED--	C7	+6V Aux
8	--RESERVED--	C8	N.C.
Note: the reserved pins have to be left <u>unconnected</u>		C9	OUT (E)
		C10	OUT (C)
FX1 - Power connections		FX2 - Current sensing inputs	
AUX	AUX	S1	C.T. input
COM	Common	S2	C.T. input
+Ecc	Excitation output +		
-Ecc	Excitation output -		
Vsense	Voltage sensing input		
PE	PE		

2.3.2 Device connections: power and high voltage

Terminal designation	Signal	Specifications
Power electronics supply	AC input voltage single-phase	80÷300 Vac 40÷400 Hz
Measurements inputs	1 Generator voltage	<ul style="list-style-type: none"> 0÷500 Vrms Not isolated: one terminal common with power supply
	1 Generator current	<ul style="list-style-type: none"> 0÷5 Arms galvanic isolation
Excitation output	Excitation voltage	3÷300 VDC
	Excitation current	0÷8 A (16 A for 10 s)

2.3.3 Device connections: control signals and interfaces

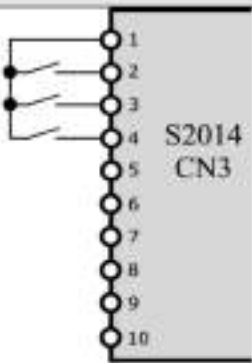
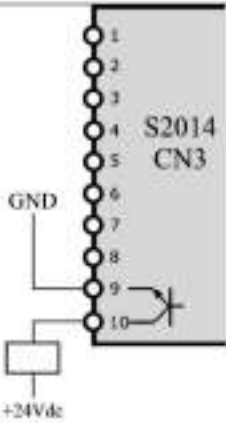
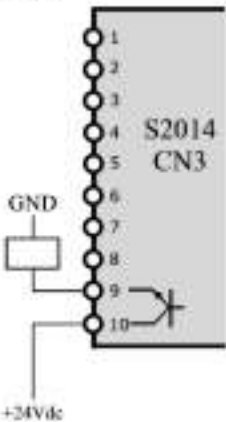
Terminal designation	Signal	Specifications
<u>Digital inputs</u>	3 programmable digital inputs	<div data-bbox="885 454 1137 814" style="text-align: center;">  <p>S2014 CN3</p> </div> <ul style="list-style-type: none"> • 4mA • Up / Down / programmable function • not isolated from power supply
<u>Digital outputs</u>	1 programmable digital output	<div data-bbox="899 940 1125 1360" style="text-align: center;">  <p>S2014 CN3</p> </div> <div data-bbox="899 1360 1125 1780" style="text-align: center;">  <p>S2014 CN3</p> </div> <ul style="list-style-type: none"> • Load Max 65mA 24Vdc

Analog inputs

2 analog inputs

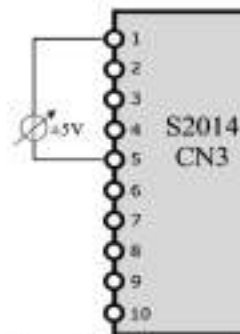

- input $\pm 5V$ for reference adjust
- **not isolated from power supply**

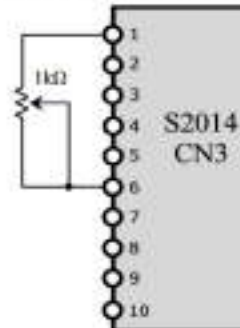

- potentiometer 1K Ω 5% for ref. adjust
- **not isolated from power supply**

Communication

1 RS485

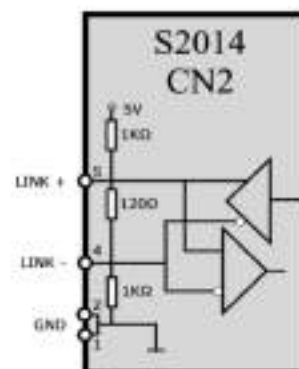

- Modbus RTU and proprietary protocols
- half duplex
- **not isolated from power supply**

2.4 Software

2.4.1 Operating modes

Bump less changeover between all modes of operation

Automatic voltage regulator (Auto)

Regulates the terminal voltage of the synchronous machine.

Note: Current measurement is optional:
used only for droop compensation

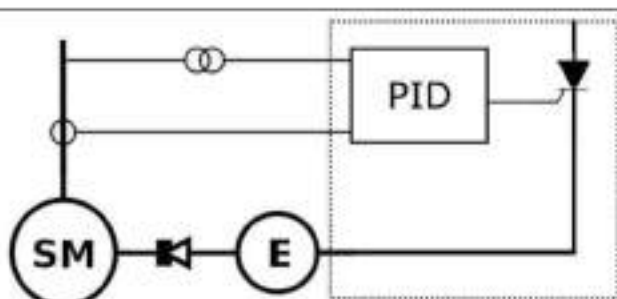

PF or Var regulation (PF, Var)

Regulates the power factor or reactive power of the synchronous machine.

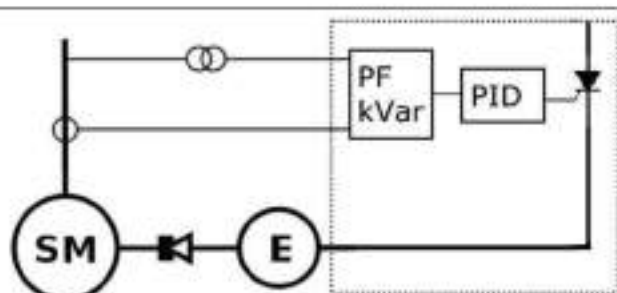

3. DESCRIPTION OF THE FUNCTIONALITY

3.1 Soft Start

Thanks to the configuration of the following parameters, it is possible to set up the excitation ramp of the alternator as follows:

Parametro	Descrizione (short)	Descrizione
P.100	Gen rate voltage	Generator rated voltage [V]
P.101	Max Gen. voltage	Generator maximum voltage [%]
R.002	Ramp slope	Ramp slope [%/s]

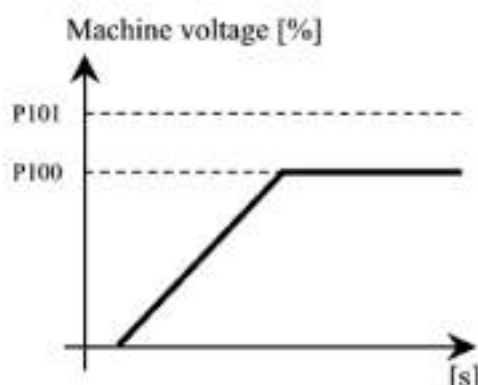

A soft start is done only in the AVR mode

3.2 Droop Compensation

The compensation function ($K > 0$) is used in order to cancel the voltage drop in the possible transformer, which is downstream connected with the alternator.

The 'droop' function ($K < 0$) is to be used if you are operating with more generators in parallel. It is applied a voltage reduction according to the output of the reactive power.

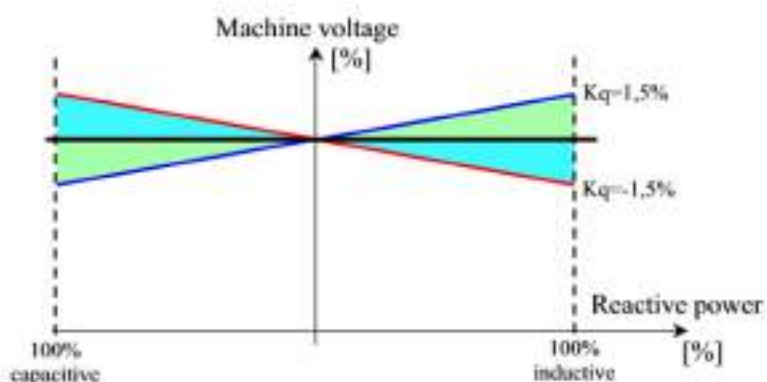

This function is enabled only in AVR mode. The input must be configured as follows: $100x = 4$.

Parametro	Descrizione (short)	Descrizione
P.400	Voltage comp K	Voltage comp [%]

3.3 'Keep alive'

This feature allows to maintain a minimum excitation current even when the alternator frequency drops below the minimum (P.130).

The parameter P.250 is the one, where the minimum excitation current must be set up; this setting must be done based on the power source (set up to 0 if the power is from PMG or auxiliary).

The AVR S2014 works to maintain an input auxiliary voltage of 60V in order to feed itself.

Parameter	Description (short)	Description
P.250	KeepAlive min I	Keep Alive minimum I
P.130	Gen. V/f min freq	Generator V/f minimum frequency

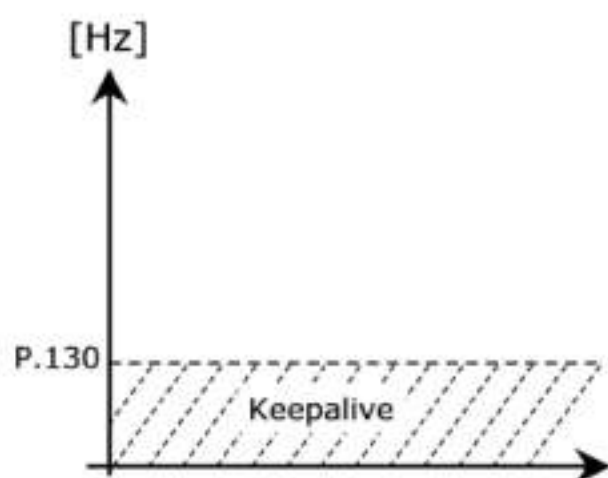

Having P.250 = 0 under the alternators minimum frequency the output will be disabled.

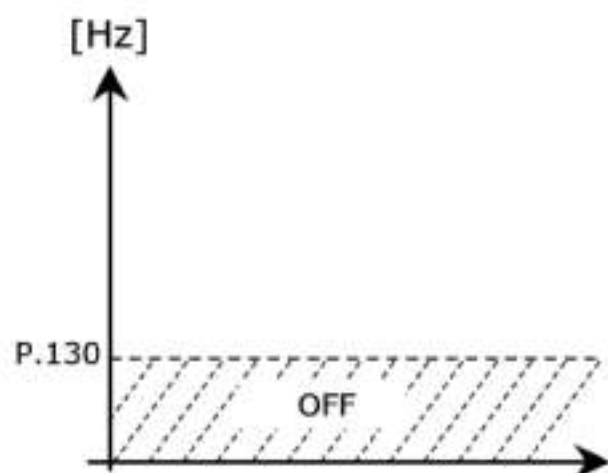

3.4 Limiters

3.4.1 V/f Limiter

The V / Hz limit is active during the voltage control phase. It works by limiting the alternator voltage as the frequency falls below the maximum frequency set in parameter P.131. This operation can avoid an alternator over-flushing in case of a reduction of laps.

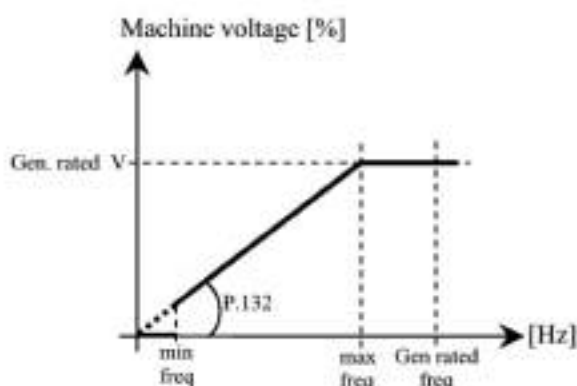

Parameter	Description (short)	Description
P.100	Gen. rated V	Generator rated voltage [V]
P.130	Gen. V/f min freq	Generator V/f minimum frequency [Hz]
P.131	Gen. V/f Max freq	Generator V/f maximum frequency [Hz]
P.132	V/f slope	Generator V/f slope

3.4.2 Minimum excitation current

The limit of minimum excitation current is only active when the machine is in parallel with Main.

It represents the minimum excitation current below which the machine cannot work.

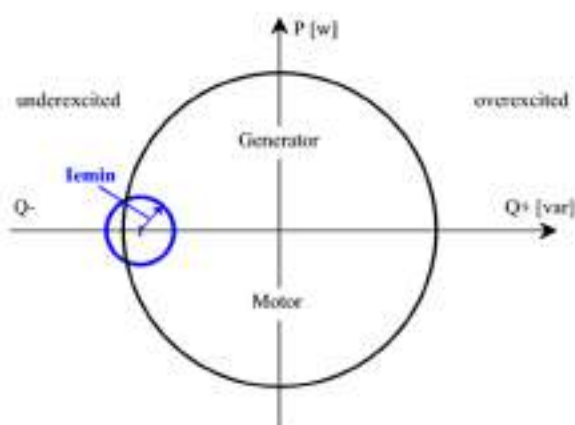

Parameter	Description (short)	Description
P.002	F. UE Lim	Field UE Lim. [%]
r.900	OE/UE Lim reg KP	OE/UE Lim. Reg. KP
r.901	OE/UE Lim reg TI	OE/EU Lim. Reg. TI

3.4.3 Maximum excitation current

The limit of maximum excitation current operates a limitation on the maximum excitation current.

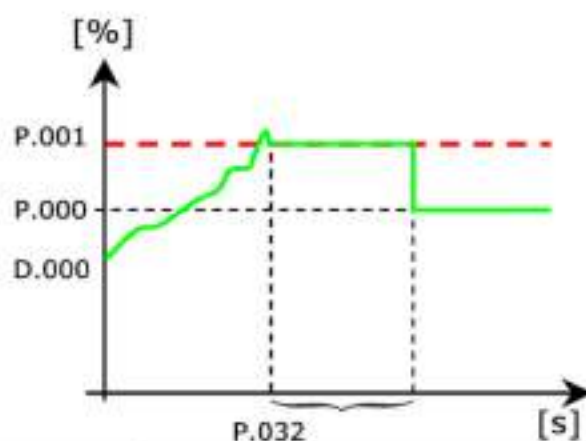

Parameter	Description (short)	Description
P.000	F. rated I	Field rated I [A]
P.001	F. OE Lim	Field OE Lim. [%]
P.032	F. OE Lim time	Field OE Lim time [s]
r.900	OE/UE Lim reg KP	OE/EU LIM reg KP
r.901	OE/UE Lim reg TI	OE/EU LIM reg TI

3.4.4 Minimum capability

The curve of minimum capability represents the reactive power limit absorbed by the machine. It is determined by interpolating 5 data:

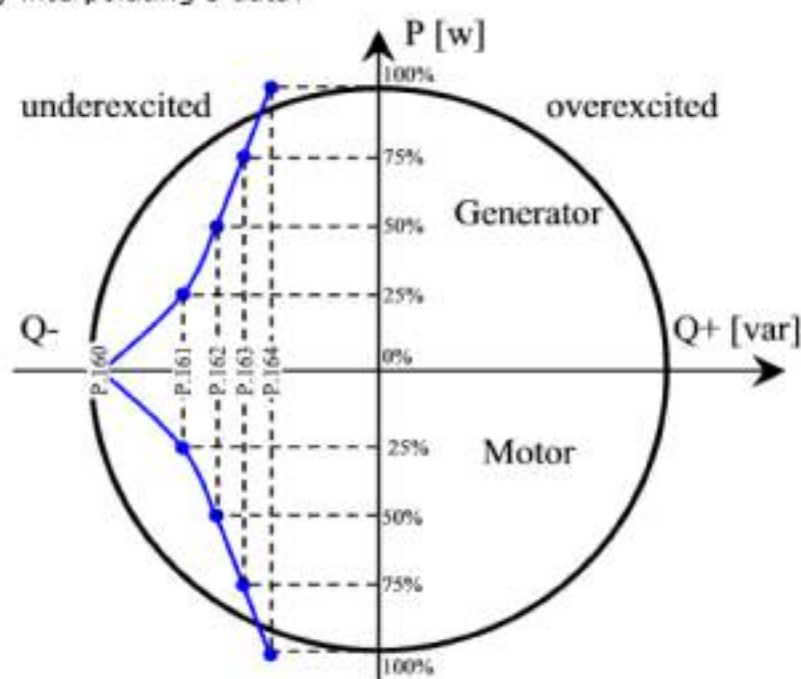

Parameter	Description (short)	Description
P.160	Q - lim @ P 0%	Limit Q- a P=0%
P.161	Q - lim @ P 25%	Limit Q- a P=25%

P.162	<i>Q - lim @ P 50%</i>	Limit Q- a P=50%
P.163	<i>Q - lim @ P 75%</i>	Limit Q- a P=75%
P.164	<i>Q - lim @ P 100%</i>	Limit Q- a P=100%

3.4.5 Massima capability

The curve of maximum capability represents the reactive power limit delivered by the machine. It is determined by interpolating 2 data:

- Q+ limit a P=0% P.170 [%]
- Q+ limit a P=100% P.171 [%]

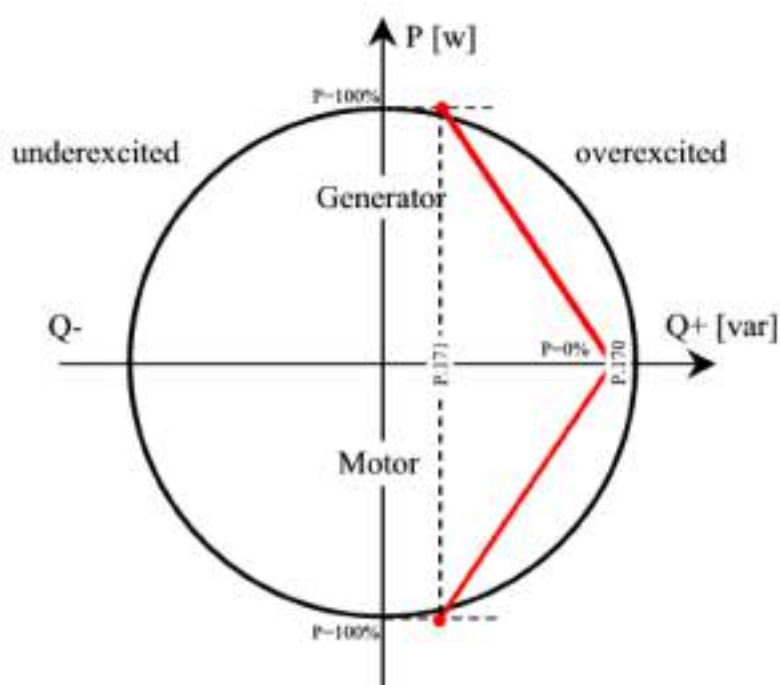

Parameter	Description (short)	Description
P.170	<i>Q + lim @ P 0%</i>	Limit Q+ a P=0%
P.171	<i>Q + lim @ P 100%</i>	Limit Q+ a P=100%

4. REFERENCES AND REGULATIONS

AVR [Automatic Voltage Regulator]

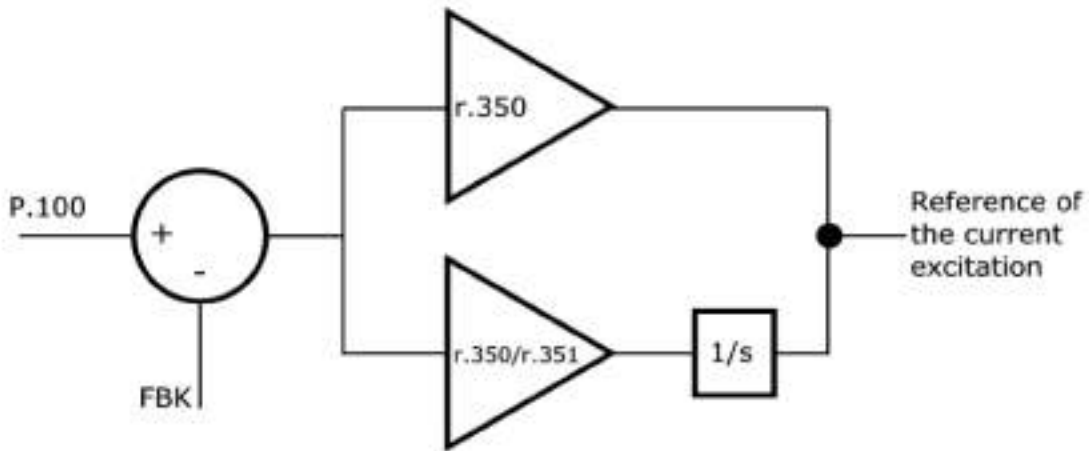

FCR [Field Current Regulation]

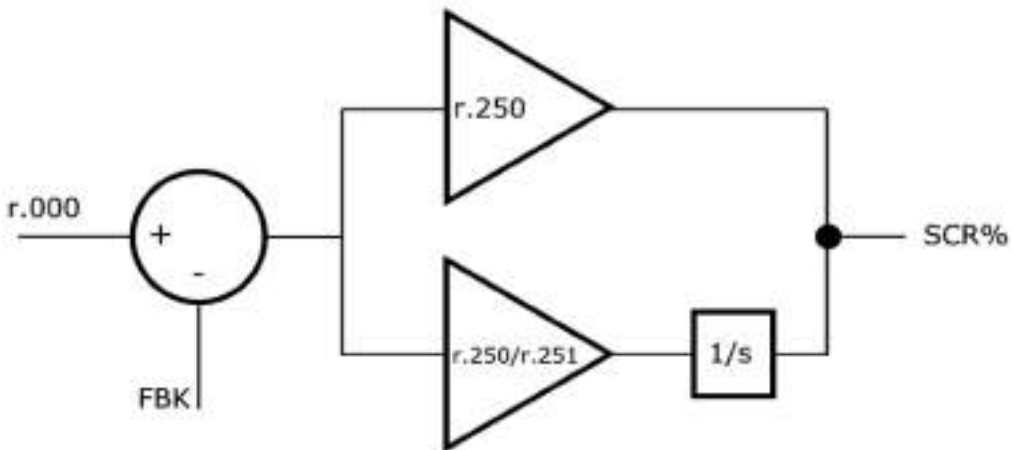

PF/VAR Control

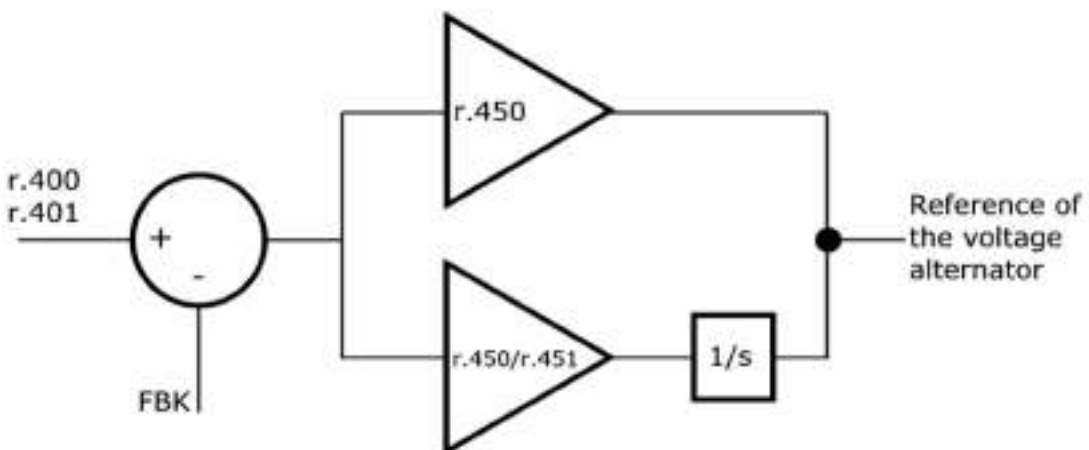

4.1 Field Current Regulation (FCR)



This functioning mode allows to control the regulator output current. In this case the regulator controls only the output current to the regulator excitation terminals without considering what happening externally.

This functioning mode could become useful during the regulator commissioning phase or in case of the eventual failure search.

Parameter	Description	Note
r.000	F. I digital	% compared to P.000
r.002	Ramp slope [s]	%/s
r.250	Field I Reg KP	
r.251	Field I Reg TI	
r.010	Delta Ref calibrator	%
r.011	Delta Ref analog	%
r.012	Delta ramp slope	%/s

4.2 Automatic voltage regulator (AVR)

The regulator controls automatically the output voltage to generator terminals.

This is the main functioning mode.

The AVR function is active when the parameter P300 = 1 is set and when the configured input I00X = 4 is closed.

Parameter	Description	Note
P.100	Generator rated voltage	V rms
r.002	Ramp slope [s]	%/s
r.350	Generator V Reg KP	
r.351	Generator V Reg TI	
r.010	Delta Ref calib	%
r.011	Delta Ref analog	%
r.012	Delta ramp slope	%/s

4.3 Automatic Power Factor regulation (PF)

The regulator controls in automatic mode the power factor at generator terminals.

The AVR function is active when the parameter P300 = 1 is set and when the configured input IOOX = 5 is closed.

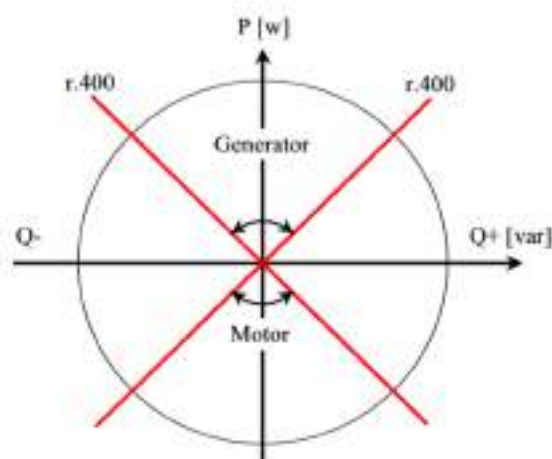

Parameter	Description	Note
r.400	Generator PF digital ref	
r.402	Ramp slope	
r.450	PF/VAR Reg KP	
r.451	PF/VAR Reg TI	
r.410	Delta Ref calibrator	
r.411	Delta Ref analog	
r.412	Delta ramp slope	

4.4 Automatic reactive power regulation (VAR)

The regulator controls in automatic mode the reactive power at generator terminals.

The AVR function is active when the parameter P300 = 1 is set and when the configured input IOOX = 5 is closed.

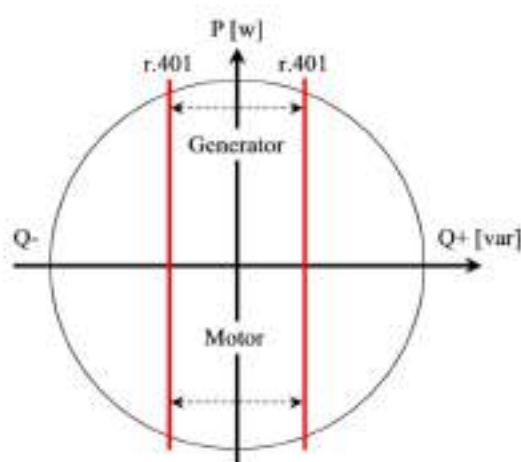

Parametro	Descrizione	Note
r.401	Generator VAR digital reference	% compared to P.100 xP.110
r.402	Ramp slope	
r.450	PF/VAR Reg KP	
r.451	PF/VAR Reg TI	

r.410	Delta Ref Calibrator	
r.411	Delta Ref analog	
r.412	Delta ramp slope	

4.5 Digital reference adjust by calibrator (U/Down)

Thanks to the programmed digital inputs (IOOX = 1 increase, IOOX = 2 decrease) it is possible to vary the reference in a range between the maximum and the minimum of parametrized delta.

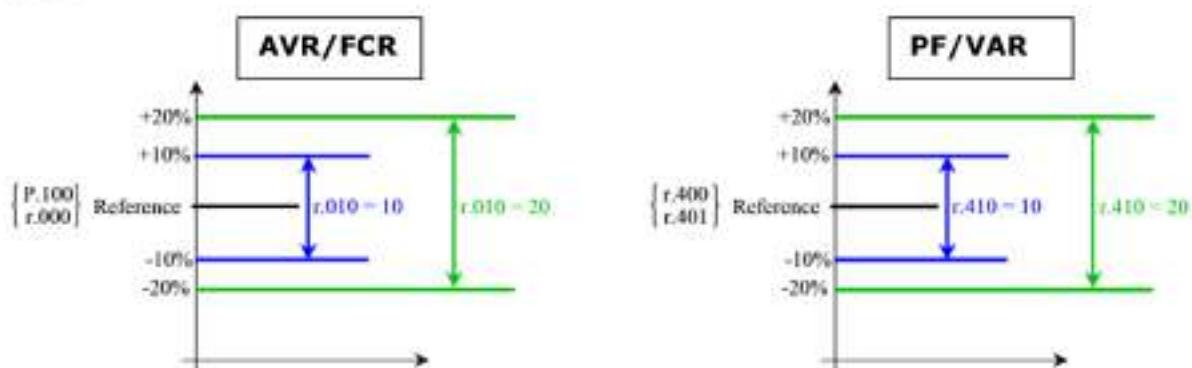

4.6 Digital reference adjust by analog (Pot/An. In)

Via the analog inputs (potentiometer or input $\pm 5V$) it is possible to vary the reference in a range between the maximum and the minimum of parametrized delta.

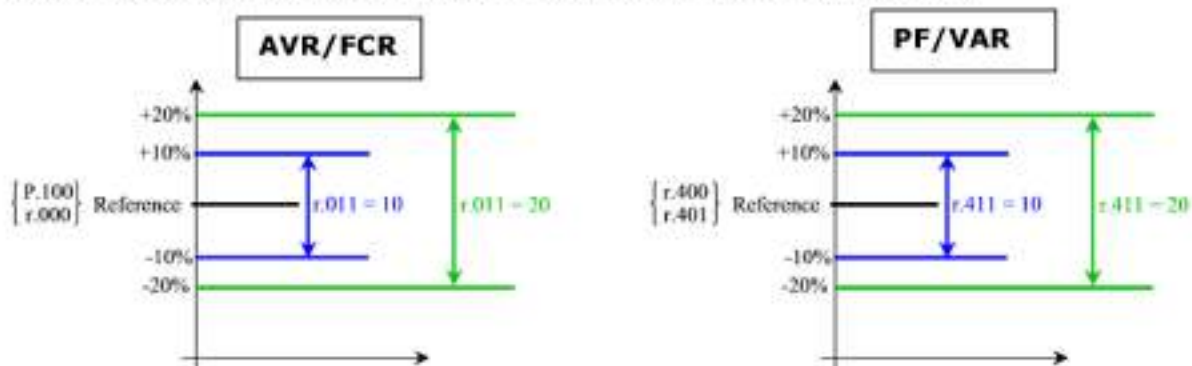

5. OPERATOR INTERFACE

In this chapter, it is described how parameters are managed by using the programming keypad.

5.1 Control keypad and display

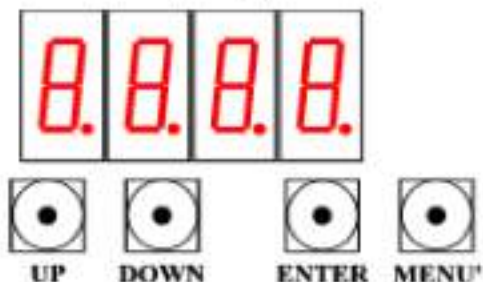

- M** Scroll menu: allows to change parameter menu (d, r, I, P)
- E** key Enter: used to begin parameter setting and/or to confirm value
- +** key UP: used to increase displaying parameter and/or numerical value
- key DOWN: used to decrease displaying parameter and/or numerical value

5.2 Navigating the menus

While the S2014 is working the parameter d000 is shown automatically in the Display menu.

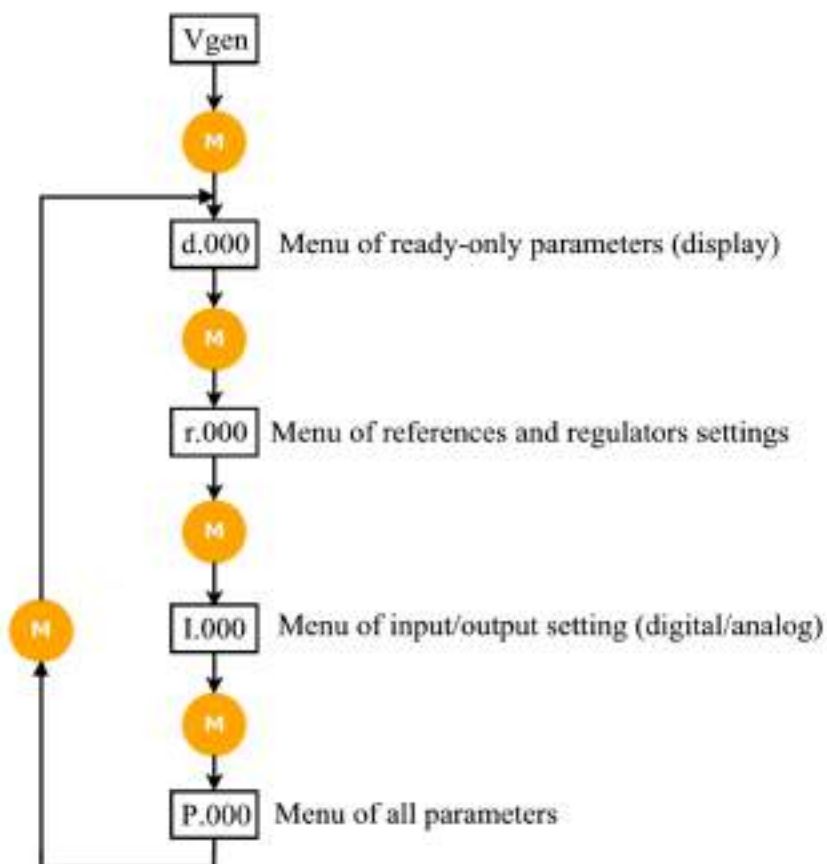

Example: how to change a Rated voltage generator reference

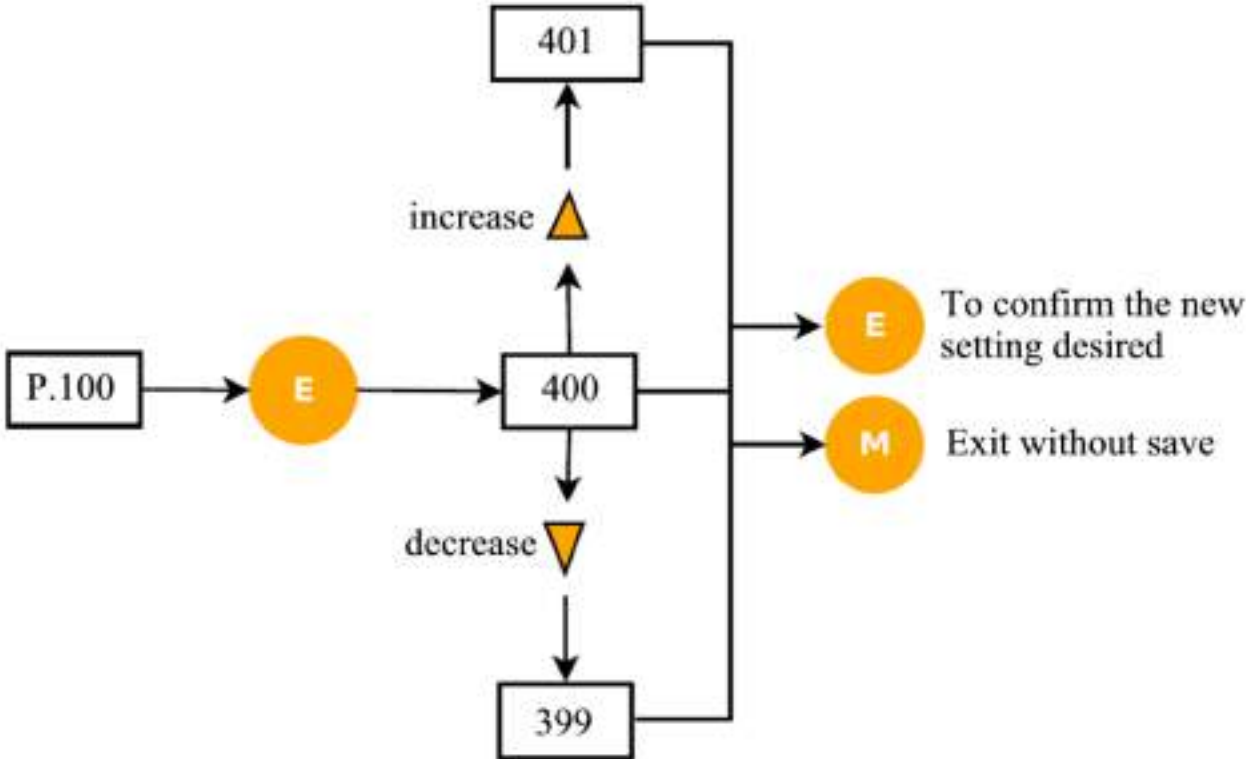

5.3 Menu

5.3.1 Menu d – Display

DISPLAYS	Name	IPA	Description	[U.M.]	Min	Default	Max	Notes, values
Field	d.000	0	Field Current	%	0,0	-	200,0	% of P.000
	d.020	1	Out Duty Cycle	%	0,0	-	100,0	
Generator output	d.100	2	Gener. V	%	0,0	-	-	% of P.100
	d.104	3	Gener. Freq.	Hz	0,00	-	99,99	
	d.110	4	Gener. Current	%	0,0	-	-	% of P.110
	d.111	5	Gener. PowerFact	-	0,25 c	-	0,25 i	Capacitive / Inductive
	d.120	6	Gener. Power S	%	0,0	-	-	% of P.100xP.110
	d.121	7	Gener. Power P	%	-d.120	-	d.120	% of P.100xP.110
d.122	8	Gener. Power Q	%	-d.120	-	d.120	% of P.100xP.110	
Exciter	d.950	9	FM var. & rev.	-	-	-	-	xx.yy(hex)
	d.952	10	SN	-	-	-	-	y.nnn
	d.997	11	Heatsink Temp.	°C	-5	-	110	
	d.999	12	AUX V	V	0,0	-	-	

5.3.2 Menu r – References and Regulators

REFERENCES & REGULATORS	Name	IPA	Description	[U.M.]	Min	Default	Max	Notes, values
Primary regulator	r.000	200	F. I digital ref	%	0	0,0	P.001	% of P.000
	r.002	201	Ramp slope	%/s	0,1	50,0	999,9	
	r.010	202	Delta Ref calib	%	0	20	200	
	r.011	203	Delta Ref analog	%	0	20	200	
	r.012	204	Delta ramp slope	%/s	0,1	1,0	10,0	
Field current regulator	r.250	205	F. I Reg KP	-	0,01	0,50	99,99	
	r.251	206	F. I Reg TI	1/(2*AuxF)	0,1	20,0	100,0	related to Aux supply period
Generator voltage regulator	r.350	207	G. V Reg KP	-	0,01	0,50	99,99	
	r.351	208	G. V Reg TI	1/(2*GenF)	0,1	20,0	100,0	related to generator period
Secondary regulator	r.400	209	G. PF dig. ref	-	0,50c	1,00	0,50i	Capacitive / Inductive
	r.401	210	G. VAR dig. ref	%	-100	0	100	% of P.100xP.110
	r.402	211	Ramp slope	%/s	0,1	1,0	100,0	
	r.410	212	Delta Ref calib	%	0	20	100	
	r.411	213	Delta Ref analog	%	0	20	100	
	r.412	214	Delta ramp slope	%/s	0,1	1,0	10,0	
PF/VAR	r.450	215	PF/VAR Reg KP	-	0,01	0,50	99,99	
	r.451	216	PF/VAR Reg TI	10/(2*GenF)	0,1	20,0	100,0	related to generator period
Aux voltage regulator	r.650	217	AuxV Reg KP	-	0,01	0,50	99,99	
	r.651	218	AuxV Reg TI	1/(2*AuxF)	0,1	20,0	100,0	related to Aux supply period
	r.900	219	OE/OE LIM Reg KP	-	0,01	0,25	99,99	
	r.901	220	OE/OE LIM Reg TI	1/(F reg)	0,1	40,0	100,0	related to generator period

5.3.3 Menu I – Inputs and outputs

I/Os	Name	IPA	Description	[U.M.]	Min	Default	Max	Notes, values
Digital inputs	I.000	600	Dig inp 1 cnf	-	0	1	6	0 NONE 1 SET RAISE 2 SET LOWER 3 MANUAL FCR 4 GRID PAR (VDC) 5 GRID PAR (PF) 6 GRID PAR (VAR)
	I.001	601	Dig inp 2 ofg	-	0	2	6	
	I.002	602	Dig inp 3 cfg	-	0	5	6	
Digital outputs	I.100	603	Dig out 1 cnf	-	0	3	4	0 NONE 1 FAULT 2 NOT FAULT 3 LIMIT 4 NO LIMIT
RS485	I.400	604	RS485 config	-	0	0	4	0 custom protocol 1 Modbus RTU 8N1 2 Modbus RTU 8E1 3 Modbus RTU 8O1 4 Modbus RTU 8N2
	I.401	605	RS485 bitrate	-	0	2	5	
	I.402	606	RS485 node ID	-	1	1	247	
	I.404	607	RS485 delay	s	0,000	0,001	0,100	

5.3.4 Menu P – Parameters

PARAMETERS	Name	IPA	Description	[U.M.]	Min	Default	Max	Notes, values
Field excitation data	P.000	1000	F. rated I	A dc	1,0	5,0	10,0	
	P.001	1001	F. OE Lim	%	100	150	250	% of P.000
	P.002	1002	F. UE Lim	%	0	5	50	% of P.000
	P.032	1003	F. OE Lim time	s	1	10	240	
Generator data	P.100	1004	G. rated V	V rms	50	100	500	
	P.101	1005	G. max V	%	105	120	120	% of P.100
	P.110	1006	G. rated I	A rms	0,20	2,50	5,00	
	P.130	1007	G. V/f min freq	Hz	20	30	150	
	P.131	1008	G. V/f max freq	Hz	P.130	45	250	
	P.132	1009	G. V/f slope	-	1,0	2,0	4,0	
	P.160	1010	Q - lim # P 0%	%	-100	-40	-5	% of P.100 x P.110
	P.161	1011	Q - lim # P 25%	%	-100	-35	-5	% of P.100 x P.110
	P.162	1012	Q - lim # P 50%	%	-100	-30	-5	% of P.100 x P.110
	P.163	1013	Q - lim # P 75%	%	-100	-25	-5	% of P.100 x P.110
P.164	1014	Q - lim # P 100%	%	-100	-20	-5	% of P.100 x P.110	
P.170	1015	Q + lim # P 0%	%	5	80	100	% of P.100 x P.110	
P.171	1016	Q + lim # P 100%	%	5	60	100	% of P.100 x P.110	
Power supply	P.250	1017	KeepAlive min I	%	5	50	2	% of P.000 set 0 for PMG or other independent Power Supply
Control mode	P.300	1018	Primary reg.	-	0	1	1	0 FCR 1 AVR
Voltage Droop Compensation	P.400	1019	Voltage comp K	%	-10,0	0,0	10,0	% of P.100 @ Q = 100%
Access control	P.981	1020	Password	-	0	1	9999	0 --> no password

6. MAINTENANCE AND FAULTS

6.1 Safety regulations



WARNING!

The secondary voltage of the excitation transformer and the rotor field voltage are fed into the excitation cabinet.

These components present a great danger of electric shocks.

Maintenance work shall only be carried out on the electrical installation if the system has been switched off and protective grounds installed.

6.2 Maintenance

When the system is at a standstill, check the fastening of faston terminals on the regulator.

6.3 Trouble shooting

The following instructions are supposed to assist in localizing a fault within the excitation system as a whole. However, it is not possible to deal with all eventualities in full.

List of possible faults

Possible causes	Checks, action
Machine is not excited	
<ul style="list-style-type: none"> Field circuit interrupted Field circuit-breaker does not close 	<ul style="list-style-type: none"> Check wiring for break Check field circuit-breaker
<ul style="list-style-type: none"> No electronics supply 	<ul style="list-style-type: none"> Measure power supply Aux - Com Check for tripped protective circuit-breaker Check builtin fuse
<ul style="list-style-type: none"> Set point error 	<ul style="list-style-type: none"> Check operating mode Check programmable digital input setting and connection Check set point

Overvoltage during build-up	
<ul style="list-style-type: none"> Overvoltage caused by voltage regulator 	<ul style="list-style-type: none"> Generator voltage present (measure voltage sensing input at terminals Vsens and Common Aux) Check system data Check set point Check overvoltage threshold Check regulator settings
Machine voltage not stable in no-load operation	

• Regulator error	<ul style="list-style-type: none"> • Check operating mode. • Check programmable digital input setting and connection • Check set points • Check parameters of voltage regulator
• Set point error	<ul style="list-style-type: none"> • Higher, lower inputs unstable • Externally input set point adjust unstable
• Control element fault	<ul style="list-style-type: none"> • Check wiring, loose contact V generator, Excitation current

Parallel operation with grid unstable.

Periodic oscillation of reactive and possibly active power

• Regulator settings incorrect	<p>Were changes made to the grid configuration? Are additional outputs, loads etc. installed?</p> <ul style="list-style-type: none"> • Yes: re-set regulator • No: check parameters of Auto and PF, Var regulator
--------------------------------	---

Irregular instability, i.e. sporadic over - or under excitation which is not caused by grid

• Droop influence of the voltage regulator ineffective or CT measurement defective	<ul style="list-style-type: none"> • Check droop compensation setting • Check external current transformer circuit • Gen CB Closed Status not active • Check programmable digital input setting and connection
• Machine within inadmissible operating range (normally protected by limiters)	<ul style="list-style-type: none"> • Bring machine into normal operating range by adjusting the set point. • Check setting of limiters

Operating point cannot be adjusted

• Set point error	<ul style="list-style-type: none"> • Check operating mode. • Check programmable digital input setting and connection • Check set point
• Limiter active	<ul style="list-style-type: none"> • Bring machine into normal operating range by adjusting the set point. • Check setting of limiters

External controls faulty

• No external control voltage	<ul style="list-style-type: none"> • Measure control voltage • Check wiring
• Configuration of the digital or analog inputs are not correct	<ul style="list-style-type: none"> • Check configuration

6.4 Repair

A defective unit should be sent back for repair.

7. GENERAL DATA

Ordering information

Device designation S2014

Mechanical data

Weight max 600 g

Protection class IP00 (limited by faston-type terminals, IP50 if terminals are protected by an external isolation screen)

Dimensions (LxWxH) 138x58x55 mm

Climatic stability

Temperature range for operation:	0 to 55 °C
Temperature range for storage:	-20 to +80 °C
Vibration:	5 mm, 2 G, 5<f<150 Hz

Electrical data

Power electronics supply:	80÷300Vac, 40 to 400 Hz
Excitation output:	- maximum continuous current 8 A - current reduction for ambient temperatures >50 °C 1 A/degree - overload (maximum 10 s) 16 A
Frequency range of measuring values Vgen and Igen	10 to 100 Hz
Accuracy:	Voltage regulation <0.5%

Test voltage: power electronics supply against case 2500 Vdc, 2 s

Voltage measurement inputs Vgen, without galvanic separation

Relevant standards, CE conformity

EMC directive: 89/336/EEC

Generic emission standard EN 50081-2 (IEC 61000-6-4)

Generic immunity standard IEC/EN 61000-6-2

