

ENERMAX SERIES

DIESEL GENERATOR
GROUPE ELECTROGENE DIESEL
GRUPO ELECTROGENO DIESEL
GRUPPO ELETTOGENO DIESEL

MODEL
 MODELE
 MODELO
 MODELLO

PK 22 TSX



SOUNDPROOF VERSION

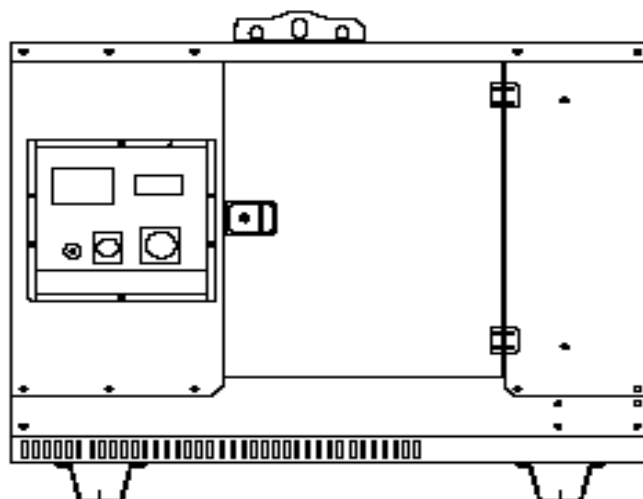

GENERATING SET PERFORMANCE PERFORMANCES DU GROUPE PRESTACIONES DEL GRUPO PRESTAZIONI DEL GRUPPO		50 Hz	60 Hz
Voltage Voltage Voltaje Tensione		V 400 / 230	V --
Continuous Power Puissance service continue Potencia servicio continuo Potenza servizio continuo	PRP	kVA 20,0	kVA --
Stand-by Power Puissance service secours Potencia servicio emergencia Potenza servizio in emergenza	LTP	kVA 22,0	kVA --
Continuous Power Puissance service continue Potencia servicio continuo Potenza servizio continuo	PRP	kWe 16,0	kWe --
Stand-by Power Puissance service secours Potencia servicio emergencia Potenza servizio in emergenza	LTP	kWe 17,6	kWe --
Power factor Facteur de puissance Factor de potencia Fattore di potenza	cos φ	0,8	--
Fuel consumption Consommation combustible Consumo de combustible Consumo combustibile	70 %	l/h 3,6	l/h --

ENGINE MOTEUR MOTOR MOTORE		PERKINS		404A-22G1	
PERFORMANCE PERFORMANCES PRESTACIONES PRESTAZIONI		1500 rpm		1800 rpm	
Continuous Power Puissance service continue Potencia servicio continuo Potenza servizio continuo	PRP	kWm	18,4	kWm	--
Stand-by Power Puissance service secours Potencia servicio emergencia Potenza servizio in emergenza	LTP	kWm	20,3	kWm	--
Specific fuel consumption Consumption spécifique combustible Consumo específico de combustible Consumo specifico combustibile		g/kWh	50 % 258 75 % 238 100 % 237 110 % 244	g/kWh	50 % -- 75 % -- 100 % -- 110 % --
Diesel 4 Stroke – Injection type Diesel 4 temps – Type injection Diesel 4 tiempos – Tipo de inyeccion Diesel a 4 tempi – Tipo di iniezione					Indirect Indirecte Indirecta Indiretta
Aspiration type Type d’aspiration Tipo de aspiracion Tipo d’aspirazione					Natural Naturel Natural Naturale
Cooling system Refroidissement Sistema de refrigeracion Raffreddamento					Water Eau Agua Acqua
Speed governor Régulateur de tours Regulador Regolatore di giri					Mechanical Mécanique Mecanico Meccanico
Cylinders, numbers and arrangement Nombre et disposition des cylindres Cilindros, numero y disposicion Numero e disposizione dei cilindri					4 L
Total displacement Cylindrée totale Cilindrata total Cilindrata totale				cm ³	2216
Bore x stroke Alésage x course Diámetro x carrera Alesaggio x corsa				mm	84.0 x 100.0
Compression ratio Rapport de compression Relación de compresión Rapporto di compressione					23.3 :1
Engine electric system voltage Voltage système électrique moteur Voltaje sistema eléctrico motor Voltaggio sistema elettrico motore					12 V
Derating for temperature Déclassement pour temperature Declasamiento para temperatura Declasseamento per temperatura				0 ÷ 25°C > 25 °C	0 2 % / 10°C
Derating for altitude Déclassement pour altitude Declasamiento para altitud Declasseamento per altitudine				0 ÷ 500 m 500 ÷ 1500 m 1500 ÷ 3000 m	0 4 % / 500 m 6 % / 500 m

ALTERNATOR ALTERNATEUR ALTERNADOR ALTERNATORE		MECCALTE	
PERFORMANCE PERFORMANCES PRESTACIONES PRESTAZIONI		1500 rpm	1800 rpm
Model Modèle Modelo Modello		ECP28-M/4	---
Continuous Power Puissance service continue Potencia servicio continuo Potenza servizio continuo	40 °C	kVA kWe	20,0 16,0
Stand-by Power Puissance service secours Potencia servicio emergencia Potenza servizio in emergenza	40 °C	KVA kWe	20,5 16,4
Stand-by Power Puissance service secours Potencia servicio emergencia Potenza servizio in emergenza	27 °C	KVA kWe	21,5 17,2
Efficiency Rendement Eficiencia Efficienza		2/4 3/4 4/4	85,6 % 87,8% 87,4 %
Standard winding connections Liaison des bobinages Tipo de conexión Collegamento avvolgimenti		Y	---
Exciter Excitatrice Excitador Excitatrice	brushless rotating exciter design with solid state pivotante sans brosses avec pont de diodes pivotants puente de diodos sin escobillas rotantes rotante senza spazzole con ponte di diodi rotanti		
Poles Poles Polos Poli			4
Phases Phases Fases Fasi			3 + N
Wires Fils Hilos Morsetti			12
Voltage accuracy Regulation Voltage Regulación voltaje Regolazione tensione			± 1 %
Insulation class Classe d' isolation Classe de aislamiento Classe di isolamento			H
Enclosure Degré de protection mécanique Grado de protección mecánica Grado di protezione meccanica			IP 23
Air volume Volume d'air Volumen de aire Volume d'aria		50 Hz 60 Hz	5,3 m ³ /min 5,8 m ³ /min
Standard AVR model Modèle AVR standard Modelo AVR standard Modello AVR standard			DSR
Derating for temperature Déclassement pour température Declasamiento para temperatura Declassamento per temperatura		0 ÷ 40°C > 40 °C	0 3 % / 5°C
Derating for altitude Déclassement pour altitude Declasamiento para altitud Declassamento per altitudine		0 ÷ 1500 m 1500 ÷ 2500 m 2500 ÷ 3000 m	0 3% / 500 m 4% / 500 m

LOGISTIC INFORMATION
INFORMATIONS LOGISTIQUES
INFORMATION LOGISTICA
INFORMAZIONI LOGISTICHE

	Integrated fuel tank capacity Capacité réservoir intégré Capacidad Tanque integrado Capacità Serbatoio integrato		Weight Poids Peso Peso	Dimensions Cotes d'encombrement Medidas externas Dimensioni d'ingombro		
	(L.)		(kg)	(cm)		
	STD	EXTRA1		L	W	H
SOUND PROOF VERSION VERSION INSONORISEE VERSION INSONORISADA VERSIONE INSONORIZZATA	75	ON REQUEST	620	150	80	133

GENSET STANDARD EQUIPMENT
EQUIPEMENT STANDARD GROUPE ELECTROGENE
EQUIPAMIENTO STANDARD GRUPO ELECTROGENO
EQUIPAGGIAMENTO STANDARD GRUPPO ELETTROGENO

GB	F	E	I
<ul style="list-style-type: none"> Lifting eye Vibration dampers Integrated bunded fuel tank Battery Manual autostart control panel With DSE7310 Emergency stop button Sound proof canopy of galvanized steel with residential silencer Fork lift guides 	<ul style="list-style-type: none"> Crochet de levage Amortisseurs de vibrations Réservoir intégré avec bac de rétention Batterie Coffret de contrôle manuel autostart avec DSE7310 Bouton arrêt d'urgence Capote d'insonorisation d'acier galvanisé avec silencieux résidentiel Supports pour fourches 	<ul style="list-style-type: none"> Gancho central Apagadores de vibracion Tanque combustible integrado con bandeja para la recogida de líquidos Bateria Cuadro manual autostart con DSE7310 Botón parada de emergencia Cabina de insonorización de acero cincado con silenciador residencial Supportes para carretilla 	<ul style="list-style-type: none"> Gancio centrale di sollevamento Antivibranti Serbatoio integrato con vasca di raccolta liquidi Batteria Quadro manuale autostart con DSE7310 Pulsante arresto di emergenza Cabina di insonorizzazione di acciaio zincato con marmitta residenziale Porta forche

MANUAL AUTOSTART CONTROL PANEL
COFFRET ELECTRIQUE MANUEL AUTOSTART
CUADRO ELECTRICO MANUAL AUTOSTART
QUADRO ELETTRICO MANUALE AUTOSTART

ACP 7310 AUS

30A (400 V - 3 ph - 50Hz - 1500 rpm)

STANDARD EQUIPMENT: 4 poles circuit breaker Electronic control board DSE 7310 Control panel box key Emergency Stop button	EQUIPEMENT STANDARD: Disjoncteur de protection 4 pôles Fiche électronique DSE 7310 Clé pour serrure du coffret Interrupteur d'arrêt d'urgence	EQUIPAMIENTO STANDARD: Interruptor magnetotermico 4 polos Carta electronica DSE 7310 Llave cuadro Botón de parada de emergencia	EQUIPAGGIAMENTO STANDARD: Interruttore magnetotermico 4 poli Scheda elettronica DSE 7310 Chiave quadro Pulsante di arresto di emergenza
---	---	---	---



DSE 7310

CONTROL BOARD
CARTE ELECTRONIQUE DE CONTROL
CARTA ELECTRONICA DE CONTROL
SCHEDA ELETTRONICA DI CONTROLLO

PROTECTIONS	PROTECTIONS	PROTECCIONES	PROTEZIONI
Low oil pressure High engine temperature Low fuel level Fail to start Fail to stop Emergency stop Over/under generator frequency Over/under generator voltage Over/under speed Fuel level Belt breakage Over current Over/under battery voltage	Basse pression huile moteur Haute température moteur Basse niveau combustible Non démarrage Non arrêt Arrêt d'urgence Sur/sous générateur fréquence Sur/sous générateur voltage Sur/sourvitesses Niveau de combustible Rupture courroie Surcourant Sur/sus la tension de batterie	Baja presión aceite Elevada temperatura motor Baja nivel carburante Falta de arranque Falta de parada Parada de emergencia Sobre/bajo generatore frecuencia Sobre/bajo generatore voltaje Sobre/bajo velocidad Nivel de combustible Ruptura correa Corriente maxima Sobre/bajo voltaje de la batería	Bassa pressione olio Alta temperatura motore Basso livello di carburante Mancato avviamento Mancato arresto Stop d'emergenza Sovra/sotto frequenza generatore Sovra/sotto voltaggio generatore Sovra/sotto velocità Livello del carburante Rottura cinghia Sovracorrente Sovra/sotto tensione della batteria
DIGITAL METERS	VOYANT NUMERIQUE POUR	VISOR DIGITAL PARA	MISURATORE DIGITALE PER
Generator volts (3 phases) Generator amperes (3 phases) Generator frequency KW-meter kVA-meter Cos φ- meter Rpm meter Gen set hours counter Battery Volts	Voltmètre générateur (3 phases) Ampèremètre générateur (3 phases) Fréquencemètre générateur KW-mètre kVA- mètre Cos φ- mètre Tm mètre Totalisateur d'heures de marche Voltmètre batterie	Voltmetro (3 fases) Amperimetro (3 fases) Frecuencimetro KW- metro kVA- metro Cos φ-metro Revoluciones por minuto metro Medida horas de marcha Voltmetro batería	Voltmetro tensione generatore (3 fasi) Amperometro generatore (3 fasi) Frequenzimetro generatore KW- metro kVA- metro Cos φ-metro Gm metro Contaore di funzionamento gruppo Voltmetro batteria

**AUTOMATIC CONTROL PANEL
COFFRET ELECTRIQUE AUTOMATIQUE
CUADRO ELECTRICO AUTOMATICO
QUADRO ELETTRICO AUTOMATICO**

1) **ACP 7320 ATS**  **COMPLETE CONTROL PANEL FREE STANDING TYPE**
Equipment: control board, circuit breaker, battery charger, transfer switch, box key.
COFFRET ELECTRIQUE COMPLET TYPE ARMOIRE SEPRE DU GROUPE
Equipement : carte électronique de contrôle, disjoncteur de protection, chargeur de batterie, inverseur de source, clé coffret.
CUADRO ELECTRICO COMPLETO EN ARMARIO SEPARADO DEL GRUPO
Equipamiento: carta electronica de controllo, interruptor magnetotermico, cargador de bateria, transferencial, llave quadro.
QUADRO ELETTRICO COMPLETO SEPARATO DAL GRUPPO
Equipaggiamento: scheda elettronica di controllo, interruttore magnetotermico, carica batteria, telecommutazione e chiave quadro.

2) **ACP 7320 AMF**  **AMF CONTROL PANEL FITTED ON THE GEN-SET WITHOUT TRANSFER SWITCH**
Equipment: control board, circuit breaker, battery charger, box key.
COFFRET ELECTRIQUE MONTE SUR LE GROUPE SANS INVERSEUR DE SOURCE
Equipement : carte électronique de contrôle, disjoncteur de protection, chargeur de batterie, clé coffret.
CUADRO ELECTRICO MONTADO SOBRE EL GRUPO SIN TRANSFERENCIAL
Equipamiento: carta electronica de controllo, interruptor magnetotermico, cargador de bateria, llave quadro.
QUADRO ELETTRICO MONTATO SUL GRUPPO ELETTROGENO SENZA TELECOMMUTAZIONE
Equipaggiamento: scheda elettronica di controllo, interruttore magnetotermico, carica batteria, chiave quadro.

3) **ACP 7320 STS**  **CONTROL PANEL FITTED ON THE GEN-SET WITH TRANSFER SWITCH SUPPLIED IN A SEPARATED BOX**
Equipment: control board, circuit breaker, battery charger, box key, separate transfer switch.
COFFRET ELECTRIQUE MONTE SUR LE GROUPE + INVERSEUR DE SOURCE FOURNI DANS UN COFFRET SEPRE
Equipement : carte électronique de contrôle, disjoncteur de protection, chargeur de batterie, inverseur de source séparé, clé coffret.
CUADRO ELECTRICO MONTADO SOBRE EL GRUPO CON TRANSFERENCIAL SEPARADO
Equipamiento: carta electronica de controllo, interruptor magnetotermico, cargador de bateria, llave quadro, transferencial separado.
QUADRO ELETTRICO MONTATO SUL GRUPPO ELETTROGENO CON TELECOMMUTAZIONE SEPARATA
Equipaggiamento: scheda elettronica di controllo, interruttore magnetotermico, carica batteria, chiave quadro, telecommutazione in armadio separato.

 **DSE 7320**
**CONTROL BOARD
CARTE ELECTRONIQUE DE CONTROL
CARTA ELECTRONICA DE CONTROL
SCHEDA ELETTRONICA DI CONTROLLO**

GB	F	E	I
The DSE7320 is an Automatic Mains Failure Control Module designed to automatically start and stop diesel generating sets that include electronic and non electronic engines. The module also provides excellent genset monitoring and protection features.	La DSE7320 est une carte de contrôle projetée pour démarrer et arrêter automatiquement groupes électrogènes diesels avec moteurs électroniques et non électroniques. La carte représente un système excellent de contrôle et de protection du groupe électrogène.	La DSE7320 es una carta de control para arrancar y parar automáticamente grupos electrógenos diesel con motores electrónicos y no electrónicos. La carta constituye un excelente sistema de control y protección del grupo electrógeno.	La DSE7320 è una scheda di controllo progettata per avviare e arrestare automaticamente gruppi elettrogeni diesel con motori elettronici e non elettronici. La scheda costituisce un eccellente sistema di controllo e di protezione del gruppo elettrogeno.
FEATURES	EQUIPEMENT	EQUIPMENT	EQUIPAGGIAMENTO
Stop/restart – Auto – Manual – Start LCD display scroll Event log view Acoustic alarm	Fiche électronique de contrôle DSE7320 Disjoncteur de protection Chargeur de batterie Bouton poussoir arrête d'urgence	Ficha electrónica de control DSE7320 Interruptor magnetotermico Cargador de batería Boton de parada de emergencia	Scheda elettronica di controllo DSE7320 Interruttore magnetotermico Carica batteria Pulsante stop emergenza
DIGITAL MEASURING	MESURES NUMERIQUES	MEDIDAS DIGITALES	MISURAZIONI DIGITALI
Generator volts (3 phases) Generator amperes (3 phases) Generator frequency KW-meter kVA-meter Cos φ- meter Rpm meter Water temperature (optional) Oil pressure (optional) Gen set hours counter Mains volts Battery volts Mains frequency Charging voltage Start-counter Fuel level %	Voltmètre générateur (3 phases) Ampèremètre générateur (3 phases) Fréquencemètre générateur KW- mètre kVA- mètre Cos φ- mètre Tm mètre Température eau (facultatif) Pression huile (facultatif) Totalisateur d'heures de marche Voltmètre secteur Voltmètre batterie Fréquence réseau Tension de charge Compteur démarrages Niveau combustible %	Voltmetro (3 fases) Amperimetro (3 fases) Frecuencimetro KW- metro kVA- metro Cos φ- metro Revoluciones por minuto metro Termometro agua (opcional) Presión aceite (opcional) Medida horas de marcha Voltmetro tensión de red Voltmetro batería Frecuencia red Tensión de carga Numero de arranques Nivel carburante %	Voltmetro tensione generatore (3 fasi) Amperometro generatore (3 fasi) Frequenzimetro generatore KW- metro kVA- metro Cos φ- metro Gm metro Temperatura acqua (facoltativo) Pressione olio (facoltativo) Contaore di funzionamento gruppo Voltmetro tensione rete Voltmetro batteria Frequenza rete Tensione di carica Contavviamenti Livello carburante %
INDICATORS	INDICATEURS	INDICADORES	INDICATORI
Mains live Generator live Mains contactor closed Generator contactor closed Engine running	Présence secteur Présence tension générateur Inverseur secteur fermé Inverseur générateur fermé Moteur en marche	Presencia tensión de red Presencia tensión grupo Transferencial red cerrado Transferencial grupo cerrado Motor en marcha	Presenza tensione di rete Presenza tensione generatore Erogazione da rete Erogazione da gruppo Motore avviato
PROTECTIONS	PROTECTIONS	PROTECCIONES	PROTEZIONI
Low oil pressure High engine temperature Low fuel level Fail to start Fail to stop Emergency stop Over/under frequency Over/under voltage Over/under speed Fuel level Belt breakage Over current Over/under battery voltage	Bas pression huile moteur Haute température moteur Bas niveau combustible Non démarrage Non arrêt Arrêt d'urgence Sur/sous fréquence Sur/sous voltage Sur/sous vitesse Niveau de combustible Rupture courroie Surcourant	Baja presión aceite Elevada temperatura motor Baja nivel carburante Falta de arranque Falta de parada Parada de emergencia Sobre/bajo frecuencia Sobre/bajo voltaje Sobre/bajo velocidad nivel de combustible Ruptura correa Corriente maxima	Bassa pressione olio Alta temperatura motore Basso livello di carburante Mancato avviamento Mancato arresto Stop d'emergenza Sovra/sotto frequenza Sovra/sotto voltaggio Sovra/sotto velocità Livello del carburante Rottura cinghia Sovraccorrente
Over/under battery voltage	Sur/sus la tension de batterie	Sobre/bajo voltaje de la batería	Sovra/sotto tensione della batteria

SOUNDPROOF CANOPY
CAPOTE D'INSONORISATION
CAPOTA DE INSONORIZACION
CABINA INSONORIZZATA

GB	F	E	I
<p>The TecnoGen Super Silent soundproof canopy has been designed with the aim of achieving the maximum noise level reduction and to provide a perfect cooling of the engine. The cooling airflow is forced through fixed circuits. The canopy is suitable for tropical ambient application. The exhaust gas silencer is residential type internally mounted. The canopy is completely built of hot galvanized carbon sheet steel. The sheets have a thickness 20/10. The structure is fully bolted, fixed by a special polyethylene sealing, completely free from electrical installation. All the panels can be easily removed. The cab is provided with doors of wide opening for easy access to generating set for the maintenance operations. The soundproofing materials are highly fire resistant and self-extinguishing.</p>	<p>La capote insonorisée TecnoGen Super Silent à été conçue pour atteindre le niveau de bruit le mineur possible et un refroidissement du moteur parfait. Le souffle d'air refroidissant est canalisé en circuits fixes. La capote est apte à être utilisée dans les ambiances tropicales. Le silencieux des gaz d'échappement, de type résidentiel, est mis à l'intérieur de la capote. La cabine est construite en acier galvanisé à chaud. Les tôles ont une épaisseur de 20/10. La structure est complètement boulonnée et fixée à travers des garnitures spéciales au polyéthylène. Tous les panneaux sont facilement amovibles. La cabine est dotée de portes avec grandes ouvertures qui permettent un accès facile au groupe électrogène pour les opérations de manutention. Les matériaux d'insonorisation sont fortement résistant au feu et auto-extinguibles.</p>	<p>La capota insonorizada TecnoGen Super Silent tiene sido planeada con el objetivo de alcanzar el menor nivel de rumorosidad posible y un perfecto enfriamiento del motor. El sopro de aire es canalizado en circuitos fijos. La cabina es apta a ser utilizada en ambientes tropicales. El silenciador de los gases de descargue, de tipo residencial, es colocado dentro de la cabina. La cabina es construida en acero cincado. Las chapas tienen un espesor de 20/10. La estructura es completamente bullonata y montada con sellos especiales de polietilene. Todos los paneles son fácilmente removibles. La cabina es dotada con puertas con amplias aberturas que permiten el fácil acceso al grupo electrógeno por las operaciones de manutención. Los materiales insonorizantes son muy resistentes al fuego y auto-extinguentes.</p>	<p>La cabina insonorizzata TecnoGen Super Silent è stata progettata allo scopo di raggiungere il minor livello di rumorosità possibile e un perfetto raffreddamento del motore. Il soffio d'aria raffreddante è canalizzato in circuiti fissi. La cabina è adatta ad essere utilizzata in ambienti tropicali. Il silenziatore dei gas di scarico, di tipo residenziale, è collocato all'interno della cabina. La cabina è costruita in acciaio zincato a caldo. Le lamiere hanno uno spessore di 20/10. La struttura è completamente bullonata e fissata tramite speciali sigilli al polietilene. Tutti i pannelli sono facilmente rimovibili. La cabina è dotata di porte con ampie aperture che consentono il facile accesso al gruppo elettrogeno per le operazioni di manutenzione. I materiali insonorizzanti sono altamente resistenti al fuoco e autoestinguenti.</p>

Our quality in 13 points
Notre qualité résumée en 13 points
Nuestra calidad en 13 puntos
La nostra qualità in 13 punti

1		Internal residential silencer for lower sound levels Silencieux interne pour un niveau bas de bruit Silenciador interno para un nivel de rumorosidad más bajo Silenziatore interno per un livello di rumorosità più basso
2		Integrated fuel tank of different sizes Réservoirs de combustible disponibles, sur demande, de capacité supérieure Tanques integrados disponibles, como opción, de capacidad superior Serbatoi integrati disponibili, su richiesta, di capacità superiore
3		Control panel viewing window to easily check status of generating set Fenêtre de visualisation du panneau de contrôle pour un contrôle plus facile du status opérationnel du groupe Ventana de visualización del panel de control por un más fácil control del estatus operativo del grupo Finestra di visualizzazione del pannello di controllo per un più facile controllo dello status operativo del gruppo
4		Lockable access doors for extra safety and security Porte d'accès avec serrure pour une sûreté majeure Puertas de acceso con cerradura para una mayor seguridad Porte di accesso con serratura per una maggiore sicurezza
5		Galvanized bolts Boulons galvanisés Pernos cincados Bulloni zincati
6		Emergency stop button Interrupteur d'arrêt d'urgence Botón parada de emergencia Pulsante arresto di emergenza
7		Fuel tank cap with external key Bouchon gasoil avec clé positionne a l'extérieur Tapo gasoleo con llave situado a l'externo Tappo gasolio con chiave posizionato all'esterno
8		Fully banded base frame Réservoir amovible avec bague de retention Tanque integrado sfilabile con el envase para recoger los líquidos Serbatolo integrato sfilabile con vasca raccolta liquidi
9		Central lifting hook Crochet central d'enlèvement Gancho de elevación Gancio di sollevamento centrale
10		Doors location convenient to controls and service area Placement des portes pour rendre les contrôles plus faciles Colocación de las puertas para facilitar los controles Collocazione delle porte per facilitare i controlli
11		High serviceability level Haut niveau d'accessibilité pour la manutention Alto nivel de accesibilidad para la manutención Alto livello di accessibilità per la manutenzione
12		Large cable entry area for easy installation Grande zone d'entré des câbles pour une installation plus facile Amplia área de entrada cables para una instalación fácil Ampia area di entrata cavi per una facile installazione
13		Galvanized metal steel sheet pre-treated prior to powder coating Tôles en acier galvanisé pré-traitées avant le vernissage à poudre Chapas de acero cincado pre-tratadas antes de la pintura a polvo Lamiere di acciaio zincato pre-trattate prima della verniciatura a polvere

**SOUND PROOF VERSION DRAWING
DESSIN VERSION INSONORIZEE
DIBUJO VERSION INSONORISADA
DISEGNO VERSIONE INSONORIZZATA**

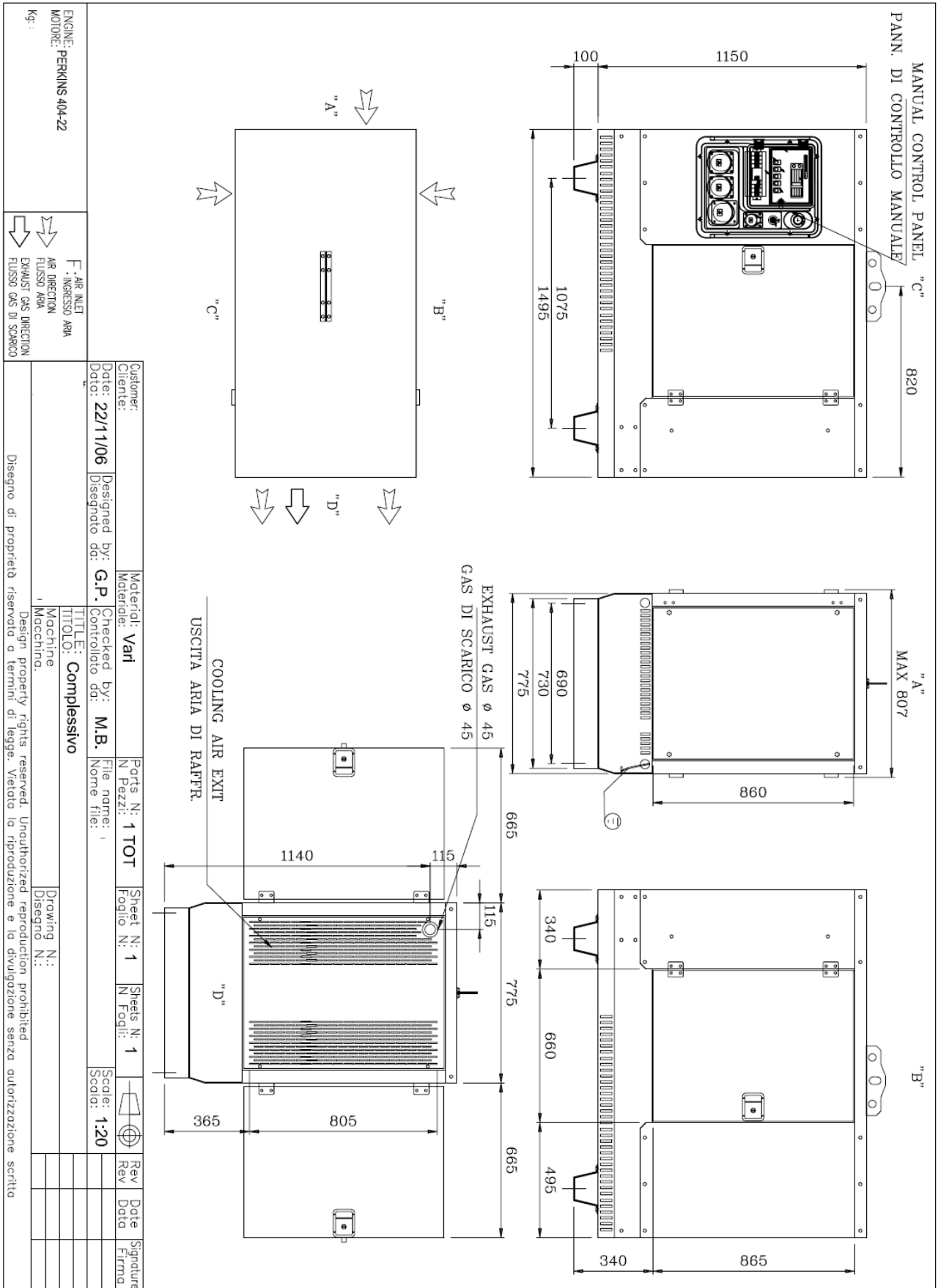

ENGINE: PERKINS 404-22 MOTORE:	F - AIR INLET -INGRESSO ARIA	Customer:	Material: Vari	Parts N: 1 TOT	Sheet N: 1	Sheets N: 1	Rev	Date	Signature
Kg:	AR DIRECTION FLUSSO ARIA	Date: 22/11/06	Checked by: G.P.	N Pezzi: 1	Foglio N: 1	N Fogli: 1	Rev	Date	Signature
	EXHAUST GAS DIRECTION FLUSSO GAS DI SCARICO	Designed by: G.P.	Controllo da: M.B.	File name:	Scale: 1:20	Scale:	Rev	Date	Signature
		TITOLO: Complessivo	Drawing N: 1	Disegno di proprietà riservata a termini di legge. Vietata la riproduzione e la divulgazione senza autorizzazione scritta					
		Machine	Macchina:						

400 Series 404A-22G1 ElectropaK

20.3 kWm @ 1500 rpm

The Perkins® 400 Series engine family continues to set new standards in the compact engine market. Developed alongside customers to fulfill their needs in the generator set, compressor, agricultural and general industrial markets.

These new ElectropaKs provide compact power, from a robust family of 3 and 4 cylinder diesel engines designed to provide economic and durable operation at prime and standby duties, hitting the key power nodes required by the power generation industry.

Powered by your needs

- The 404A-22G1 ElectropaK is a powerful but quiet 2.2 litre naturally aspirated 4-cylinder compact package

Compact, clean, efficient power

- Design features on the 400D range of ElectropaKs ensures clean rapid starting in all conditions whilst delivering impressive performance with low operating costs in a small, efficient package size

Lower operating costs

- Approved for operation on biodiesel* concentrations of up to 20%
- Oil and filter changes are 500 hours, dependent on load factor
- Engine durability and reliability, the warranty offering and ease of installation combine to drive down the cost of ownership

Product support

- With highly trained Perkins distributors in thousands of communities in over 180 countries, you are never far away from expert product knowledge, genuine parts and a range of advanced diagnostic technology for keeping your engine in peak condition

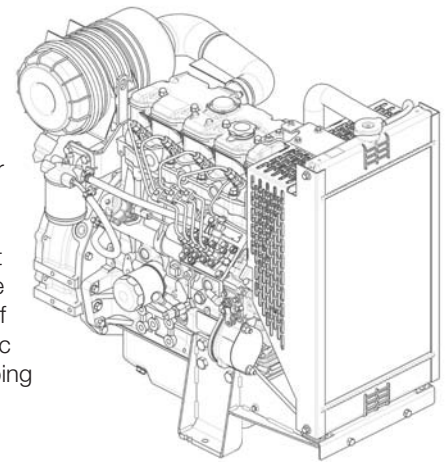

Warranties and Service Contracts

We provide one-year warranties for constant speed engines and two-year warranties for variable speed models, as standard. These are supported by multilevel Extended Service Contracts that can be bought additionally

Discover more

www.perkins.com

www.tier4air.com

www.perkins.com/esc

www.perkins.com/distributor

[To find your local distributor](#)

Engine speed	Type of Operation	Typical Generator Output (Net)		Engine Power				Low Idle
				Gross		Net		
		kVA	kWe	kWm	hp	kWm	hp	
1500	Prime power	20.3	16.2	18.7	25.1	18.4	24.7	n/a
	Standby power	22.3	17.8	20.6	27.6	20.3	27.2	n/a

The above ratings represent the engine performance capabilities to conditions specified in ISO 8528/1, ISO 3046/1:1986, BS 5514/1. Derating may be required for conditions outside these; consult Perkins Engines Company Limited. Generator powers are typical and are based on typical alternator efficiencies and a power factor (cos ϕ) of 0.8.

Fuel specification: BS 2869: Part 2 1998 Class A2 or ASTM D975 D2.

Rating Definitions: **Prime Power:** Power available at variable load in lieu of a main power network. Overload of 10% is permitted for 1 hour in every 12 hours operation. **Standby (maximum):** Power available at variable load in the event of a main power network failure. No overload is permitted.

Photographs are for illustrative purposes only and may not reflect final specification.

All information in this document is substantially correct at time of printing and may be altered subsequently.

Publication No.PN2002/06/12 Produced in England ©2012 Perkins Engines Company Limited

 **Perkins®**

THE HEART OF EVERY GREAT MACHINE

400 Series 404A-22G1

Electropak

20.3 kWm @ 1500 rpm

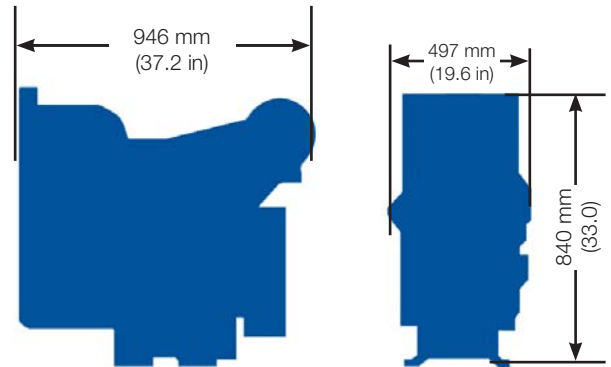
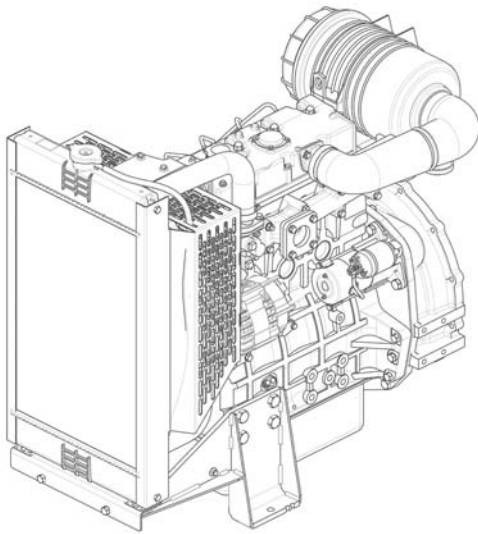

Standard electropak specification

Air inlet

- Mounted air filter

Fuel system

- Mechanically governed cassette type fuel injection pump
- Split element fuel filter

Lubrication system

- Wet steel sump with filler and dipstick
- Spin-on full-flow lub oil filter

Cooling system

- Thermostatically-controlled system with belt driven coolant pump and pusher fan
- Mounted radiator, piping and guards

Electrical equipment

- 12 volt starter motor and 12 volt 15 amp alternator with DC output
- Oil pressure and coolant temperature switches
- 12 volt shut-off solenoid energised to run
- Glow plug cold start aid and heater/starter switch

Flywheel and housing

- 1500 rpm
- High inertia flywheel to SAE J620 Size 190.5 mm (7½ in) Heavy
- Flywheel housing SAE 4 Long

Mountings

- Front and rear engine mounting bracket

Fuel Consumption		
Engine Speed	1500 rpm	
	g/kWh	l/hr
Standby	244	6.1
Prime power	237	5.3
75% of prime power	238	4.0
50% of prime power	258	2.9

General Data

Number of cylinders	4
Cylinder arrangement	Vertical in-line
Cycle	4 stroke
Aspiration	Naturally aspirated
Combustion system	Indirect injection
Compression ratio	23.3:1
Bore and Stroke	84 x 100 mm (3.3 x 3.9 in)
Displacement	2.216 litres (135.2 cubic in)
Direction of rotation	Anti-clockwise viewed on flywheel
Cooling system	Water cooled
Total coolant capacity	7.0 litres (1.8 US gals)
Total lubrication system capacity	10.6 litres (2.8 US gals)
Dimensions	
Length	946 mm (37.2 in)
Width	497 mm (19.6 in)
Height	840 mm (33.0 in)
Total weight (dry)	242 kg (533 lb)

Final weight and dimensions will depend on completed specification.

Optional equipment

- Parts book

Option groups

A selection of optional items is available to enable you to prepare a specification precisely matched to your needs.

Photographs are for illustrative purposes only and may not reflect final specification.

All information in this document is substantially correct at time of printing and may be altered subsequently.
Publication No.PN2002/06/12 Produced in England ©2012
Perkins Engines Company Limited

Perkins Engines Company Limited

Peterborough PE1 5FQ

United Kingdom

Telephone +44 (0)1733 583000

Fax +44 (0)1733 582240

www.perkins.com

 **Perkins®**

THE HEART OF EVERY GREAT MACHINE

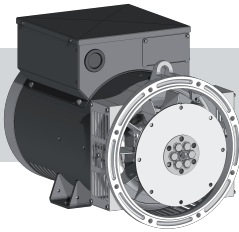

ECP28

MECCALTE spa - Via Roma, 20 - 36051 CREAZZO (VI) ITALIA
 Tel. +39 0444/396111 - Fax +39 0444/396166 - e-mail : info@meccalte.it
 web site: www.meccalte.com

4 POLE A

CHARACTERISTICS

INDUSTRIAL RATINGS

ambient 40 ° C

Type	kVA - cos φ 0.8 - 3 Phase continuous							Efficiency			1 Phase kVA COS φ 1 CL. H (ΔT= 125 °C) DELTA
	CL. H (ΔT= 125 °C)				CL. F (ΔT= 105 °C)			η % CL. H (ΔT= 125 °C)			
50 Hz	380	400	415	IP45 400 V	380	400	415	2/4	3/4	4/4	5
Series Star Y	190	200	208		190	200	208				
Parallel Star YY	220	230	240		220	230	240				
Series Delta Δ	110	115	120		110	115	120				
Parallel Delta ΔΔ											
ECP28-1VS/4	7,8	7,8	7,8	6,6	7	7	7	83,5	86,0	85,8	5
ECP28-2VS/4	11	11	11	9,3	10	10	10	83,8	86,5	86,2	7
ECP28-0S/4	13,5	13,5	13,5	11,5	12,5	12,5	12,5	84,4	86,9	86,6	8,5
ECP28-S/4	17	17	17	14,5	16	16	16	85,4	87,4	87,2	11,5
ECP28-M/4	20	20	20	17	18,5	18,5	18,5	85,6	87,8	87,4	13,5
ECP28-2L/4	25	25	25	21	23	23	23	86,1	88,1	87,8	16,5
ECP28-VL/4	30	30	30	24	26	26	26	86,5	88,5	88,1	19

Type	CL. H (ΔT= 125 °C)				CL. F (ΔT= 105 °C)			Efficiency			1 Phase kVA COS φ 1 CL. H (ΔT= 125 °C) DELTA
	CL. H (ΔT= 125 °C)				CL. F (ΔT= 105 °C)			η % CL. H (ΔT= 125 °C)			
60 Hz	440	460	480	IP45 480 V	440	460	480	2/4	3/4	4/4	6,3
Series Star Y	220	230	240		220	230	240				
Parallel Star YY	254	265	277		254	265	277				
Series Delta Δ	127	133	138		127	133	138				
Parallel Delta ΔΔ											
ECP28-1VS/4	8,8	9,4	9,4	8	7,8	8,5	8,5	84,5	87,0	86,9	6,3
ECP28-2VS/4	12,4	13,2	13,2	11	11	12	12	84,8	87,6	87,3	8,8
ECP28-0S/4	15	16,2	16,2	13,5	13,5	15	15	85,5	88,0	87,7	10,8
ECP28-S/4	18,6	20,4	20,4	17,5	17,5	19	19	86,2	88,6	88,7	13,5
ECP28-M/4	23	24	24	20,5	20	22	22	87,5	89,5	89,5	16
ECP28-2L/4	27,5	30	30	25	25,5	27,5	27,5	88	90	89,7	20
ECP28-VL/4	36	36	36	29	32	32	32	88,4	90,3	89,8	23

STANDBY RATINGS

Type	kVA Temp. Rise / Ambient °C			kVA Temp. Rise / Ambient °C		
	50 Hz			60 Hz		
	163° / 27°	150° / 40°	125° / 27°	163° / 27°	150° / 40°	125° / 27°
ECP28-1VS/4	8,4	8	8	10	9,7	9,7
ECP28-2VS/4	11,7	11,3	11,3	14	13,6	13,6
ECP28-0S/4	14,6	14	14	17,5	16,7	16,7
ECP28-S/4	18	17,5	17,5	21,6	21	21
ECP28-M/4	21,5	20,5	20,5	25,8	24,6	24,6
ECP28-2L/4	26,5	25,5	25,5	31,8	30,6	30,6
ECP28-VL/4	32,5	30,5	30,5	38,4	36,6	36,6

Type	J (kgm ²) B3/B14 FORM	Weight SAE (kg)	Air Volume		Noise dB(A)					
			50 Hz		60 Hz		50 Hz		60 Hz	
			50 Hz (m ³ /min)	60 Hz (m ³ /min)	1m	7m	1m	7m		
ECP28-1VS/4	0,0711	79	5,3	5,8	68	57	71	61		
ECP28-2VS/4	0,0821	86								
ECP28-0S/4	0,0904	96								
ECP28-S/4	0,1041	104								
ECP28-M/4	0,1182	115								
ECP28-2L/4	0,1421	136								
ECP28-VL/4	0,1636	162								

ACCESSORIES

REGULATOR				PARALLEL DEVICE	THERMAL PROTECTION			HEATERS	MECHANICAL PROTECTION	
DSR	DER-1	SR7/2	UVR6		PTC	BIMET. DEVICE	PT100		IP23	IP45
●	□	□	□	□*	□	□	□	□	●	□

● = Standard
 □ = Optional

* available if requested when placing the order

Rating



OVERALL DIMENSIONS B3-B14 FORM

dimensions in mm

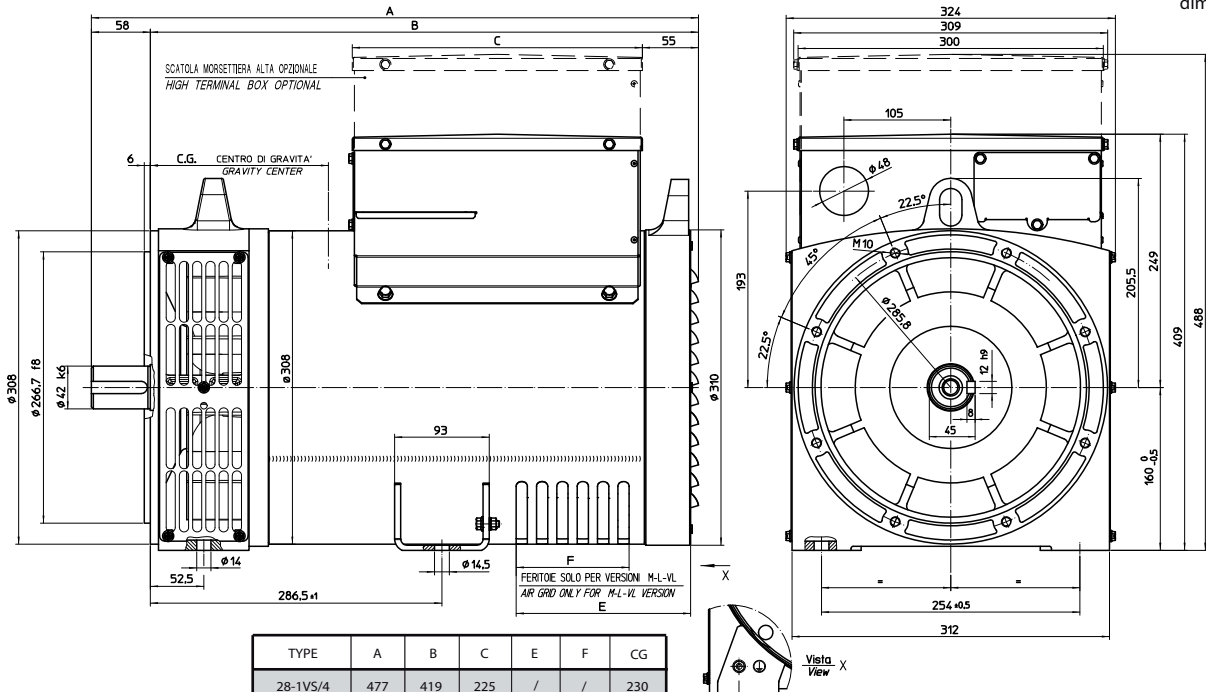

TYPE	A	B	C	E	F	CG
28-1VS/4	477	419	225	/	/	230
28-2VS/4	477	419	225	/	/	230
28-0S/4	517	459	285	/	/	235
28-S/4	517	459	285	/	/	237
28-M/4	552	494	285	131,5	71	250
28-2L/4	597	539	285	171,5	111	275
28-VL/4	627	569	285	171,5	111	286

OVERALL DIMENSIONS MD35 FORM

dimensions in mm

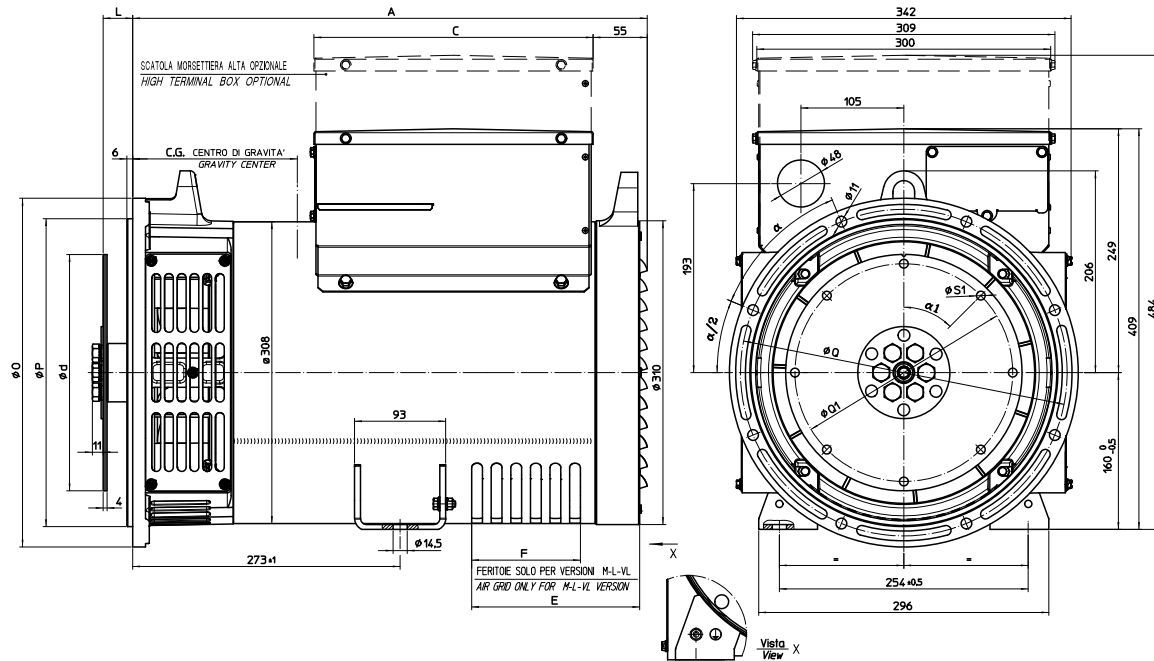

TIPO / TYPE	A	C	E	F	CG
28-1VS/4	405	225	/	/	200
28-2VS/4	405	225	/	/	200
28-0S/4	445	285	/	/	214
28-S/4	445	285	/	/	217
28-M/4	480	285	131,5	71	238
28-2L/4	525	285	171,5	111	254
28-VL/4	555	285	171,5	111	274

SAE N.	GIUNTI A DISCHI DISC COUPLING DISQUE DE MONOPALIER SCHEIBENKUPPLUNG				
	L	d	Q1	S1	α1
6 1/2	30,2	215,9	200	9	60°
7 1/2	30,2	241,3	222,25	9	45°
8	62	263,52	244,47	11	60°
10	53,8	314,32	295,27	11	45°
11 1/2	39,6	352,42	333,37	11	45°

SAE N.	FLANGIE FLANGE BRIDE FLANSCH BRIDAS			
	O	P	Q	α
5	356	314,3	333,4	45°
4	403	362	381	30°
3	451	409,6	428,6	30°
2	490	447,7	466,7	30°

DSECONTROL[®] MONITORING WITH INTELLIGENCE.



DSE7310 & DSE7320

AUTO START & AUTO MAINS FAILURE CONTROL MODULES (COMMUNICATIONS & EXPANSION)



The DSE7310 and DSE7320 are control modules for single gen-set applications. The modules have been developed from the successful DSE5310 and DSE5320 Series and incorporate a number of advanced features to meet the most demanding on-site applications.

The DSE7310 is an Automatic Start Control Module and the DSE7320 is an Auto Mains (Utility) Failure Control Module. Both modules have been designed to start and stop diesel and gas generating sets that include electronic and non-electronic engines. The DSE7320 includes the additional capability of being able to monitor a mains (utility) supply.

Both modules include USB, RS232 and RS485 ports as well as dedicated DSENet[®] terminals for expansion device connectivity.

The modules are simple to operate and feature a user-friendly menu layout for improved clarity. Enhanced features include a real time clock for enhanced event and performance monitoring, ethernet communications for low cost monitoring, mutual standby (DSE7310 only) to reduce engine wear and tear and preventative maintenance features to detect engine part faults prior to a major problem occurring.

FEATURES

- Backed up real time clock
- 132 x 64 pixel LCD display
- Configurable display languages
- Five-key menu navigation
- Fully configurable via PC software
- LED and LCD alarm indication
- Engine exercise mode
- Configurable start & fuel outputs
- kWh monitoring
- Automatic load transfer
- Eight configurable digital inputs
- Six configurable outputs
- Configurable timers and alarms
- Modbus RTU
- Magnetic pick-up
- Selected front panel programming
- Multiple date and time exercise scheduler
- SMS messaging (additional external modem required)
- Power save mode
- User selectable RS232 & RS485 communications
- DSENet[®] compatible
- Ethernet communications via DSE860/865
- Multiple date and time maintenance scheduler
- Configurable display pages
- Programmable load shedding/acceptance
- Preventative maintenance
- kW overload protection
- Unbalanced load protection
- Flexible sender input
- Configurable SCADA output page
- True dual mutual standby with load balancing timer (DSE7310 only)
- Fan control for additional cooling
- 'Protections Disabled' facility
- Fuel usage monitoring and low fuel alarm
- Support for up to three remote display units
- Automatic sleep mode
- Easy access, configurable diagnostics page shows summary of output states
- Improved programmable event log (250) showing date and time
- Manual fuel pump control
- 3 alternative configurations
- Multiple date and time scheduler
- 3 Programmable Maintenance alarms with comms alert
- Customisable status screens
- Low fuel level alarm delay
- Charge alternator fail warning and shutdown alarms with user programmable delay
- Independent Earth fault trip
- Sleep mode
- Load switching (Load shedding and dummy load outputs)
- Manual speed trim (on CAN engines that support this feature)
- Additional display screens to help with modem diagnostics
- Security levels – PC software has password system to control access to PC software features
- Operator configurable virtual LEDs visible in SCADA

NEW FEATURES

- Additional programmable logic
- Improved modem diagnostics
- Remote control sources (10) can be accessed via SCADA
- Additional electrical trip options
- Additional start delay functions
- Oil pressure values from additional engines
- Front panel editing of scheduler
- Displays kW as % of rated kW setting

SPECIFICATION

DC SUPPLY

CONTINUOUS VOLTAGE RATING
8V to 35V Continuous

CRANKING DIP PROTECTION
Able to survive 0V for 50mS, providing supply was at least 10V before dropout and supply recovers to 5V. This is achieved without the need for internal batteries

CHARGE FAIL/ EXCITATION
0V to 35V fixed power source 2.5W

MAXIMUM STANDBY CURRENT
160mA at 12V 80mA at 24V

MAXIMUM OPERATING CURRENT
340mA at 12V 160mA at 24V

ALTERNATOR INPUT

RANGE
15V - 333V (L-N) 50Hz - 60Hz
(Minimum 15V AC Ph-N)

ACCURACY
1% of full scale true RMS sensing

SUPPORTED TOPOLOGIES
3 phase 4 wire
3 phase 3 wire
3 phase 4 wire Delta
Single phase 2 wire
2 phase 3 wire L1 & L2
2 phase 3 wire L1 & L3

MAINS/UTILITY INPUT (DSE7320 ONLY)

RANGE
15V - 333V (L-N) 50Hz - 60Hz
(Minimum 15V AC Ph-N)

ACCURACY
1% of full scale true RMS sensing

SUPPORTED TOPOLOGIES
3 phase 4 wire
3 phase 3 wire
3 phase 4 wire Delta
Single phase 2 wire
2 phase 3 wire L1 & L2
2 phase 3 wire L1 & L3

CT'S

BURDEN
0.5VA

PRIMARY RATING
1A - 8000A (user selectable)

SECONDARY RATING
1A or 5A secondary (user selectable)

ACCURACY OF MEASUREMENT
1% of full load rating

RECOMMENDATIONS
Class 1 required for instrumentation
Protection class required if using for protection

SPECIFICATION

MAGNETIC PICKUP

VOLTAGE RANGE

+/- 0.5V minimum (during cranking) to 70V peak

FREQUENCY RANGE

10,000 Hz (max)

OUTPUTS

OUTPUT A (FUEL)

15 Amp DC at supply voltage

OUTPUT B (START)

15 Amp DC at supply voltage

OUTPUTS C & D

8 Amp 250V (Volt free)

AUXILIARY OUTPUTS E,F,G,H

2 Amp DC at supply voltage

DIMENSIONS

OVERALL

240mm x 181.1mm x 41.7mm
9.4" x 7.1" x 1.6"

PANEL CUT-OUT

220mm x 160mm
8.7" x 6.3"
Max panel thickness 8mm (0.3")

ENVIRONMENTAL TESTING STANDARDS

ELECTRICAL SAFETY

BS EN 60950
Safety of Information Technology Equipment,
including Electrical Business Equipment

ELECTRO MAGNETIC COMPATIBILITY

BS EN 61000-6-2
EMC Generic Immunity Standard for the
Industrial Environment
BS EN 61000-6-4
EMC Generic Emission Standard for the
Industrial Environment

TEMPERATURE (OPERATING)

BS EN 60068
Test Ab to +70°C 60068-2-2 Hot
Test Ab to -30°C 60068-2-1 Cold

VIBRATION

BS EN 60068-2-6
Ten sweeps in each of three major axes
5Hz to 8Hz @ +/-7.5mm, 8Hz to 500Hz @ 2g

HUMIDITY

BS 2011 part 2.1 60068-2-30
Test Cb Ob Cyclic
93% RH @ 40°C for 48 hours

SHOCK

BS EN 60068-2-27
Three shocks in each of three major axes
15gn in 11ms

BENEFITS

- 132 x 64 pixel ratio makes information easy to read
- Real time clock provides accurate event logging
- PC software is license free
- Set maintenance periods can be configured to maintain optimum engine performance
- Ethernet communications provides advanced remote monitoring at low cost
- Modules can be integrated into building management systems
- Preventative maintenance avoids expensive engine down time
- Advanced PCB layout ensures high reliability
- Robust design
- Extensive performance monitoring

OPERATION

The modules are operated via the START, STOP, AUTO and MANUAL soft touch membrane buttons on the front panel. The DSE7320 also has a TEST button. Both modules include load switch buttons. The main menu system is accessed using the five navigation buttons to the left of the LCD display.

CONFIGURATION

The modules can be configured using the front panel buttons or by using the DSE Configuration Suite PC software and a USB lead.

COMMUNICATIONS

The DSE7310 & DSE7320 have a number of different communication capabilities.

SMS Messaging

When the module detects an alarm condition, it has the ability to send an SMS message to a dedicated mobile number (s), notifying an engineer of the exact time, date and reason why the engine failed (GSM Modem and SIM Card required).

Remote Communications

When the module detects an alarm state, it dials out to a PC notifying the user of the condition (Modem required).

Remote Control

The module can be controlled remotely using either a GSM Modem, Ethernet via DSE860/865 or via RS485. Using a modem allows the module to be controlled from any distance. Using RS485 limits the distance to 1km (0.6 miles).

Building Management

The module has been designed to be integrated into new and existing building management systems, using RS485.

PC Software

The module has the ability to be configured and monitored from a remote PC, using the PC software and a USB lead.

INPUTS & OUTPUTS

Analogue inputs are provided for oil pressure, coolant temperature and fuel level. These connect to conventional engine mounted resistive sensor units to provide accurate monitoring and protection facilities. They can also be configured to interface with digital switch type inputs for low oil pressure and high coolant temperature shutdowns. Eight user configurable digital inputs are also included, plus one flexible sender.

Outputs are provided for fuel solenoid, start solenoid and six additional configurable outputs. On these configurable outputs a range of different functions, conditions or alarms can be selected.

INSTRUMENTATION

The modules provide advanced metering facilities, displaying the information on the LCD display. The information can be accessed using the five-key menu navigation to the left of the display.

DSENET®

DSENet® is a collection of expansion modules that have been created to work with DSENet® compatible control modules. DSENet® allows up to 20 different expansion devices to be used at a time. The expansion modules available are:

- DSE2157 Relay Output Expansion Module
- DSE2130 Input Expansion Module
- DSE2548 Annunciator Module Remote Display Module
- DSE2510 Remote Display
- DSE2520 Remote Display

EVENT LOG

The module includes a comprehensive event log that shows the most recent 250 alarm conditions and the date and time that they occurred. This function assists the user when fault finding and maintaining a generating set.

ELECTRONIC ENGINE COMPATIBILITY

- CAT
- Cummins
- Deutz
- John Deere
- MTU
- Perkins
- Scania
- Volvo
- IVECO
- Generic
- Plus additional manufacturers

RELATED MATERIALS

TITLE	PART NO'S
DSE7xxx Manual	057-074
DSE72xx/73xx PC Software Manual	057-077
DSE2130 Data Sheet	053-060
DSE2157 Data Sheet	053-061
DSE2548 Data Sheet	053-062
DSE860/865 Data Sheet	055-071
DSE2510/20 Data Sheet	055-074

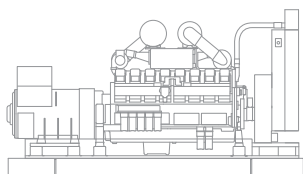

ELECTRONIC ENGINE CAPABILITY

7310

Generator Instruments

Volts, Hz, Amps, kW, kVA, Pf, kWh, kVAr, kVArh, KVArh

Engine Instruments

RPM, Oil Pressure, Coolant Temperature, Hours Run, Charging Voltage, Battery Volts.

Electronic Engines

Enhanced Instrumentation and Engine ECU diagnostics via electronic engine interface.

7320

Generator Instruments

Volts, Hz, Amps, kW, kVA, Pf, kWh, kVAr, kVArh, KVArh

Engine Instruments

RPM, Oil Pressure, Coolant Temperature, Hours Run, Charging Voltage, Battery Volts.

Electronic Engines

Enhanced instrumentation and Engine ECU diagnostics via electronic engine interface.

Mains/Utility Instruments

Volts, Frequency, Amps (optional when CT's are fitted load side of the line)

DSE7310 & DSE7320

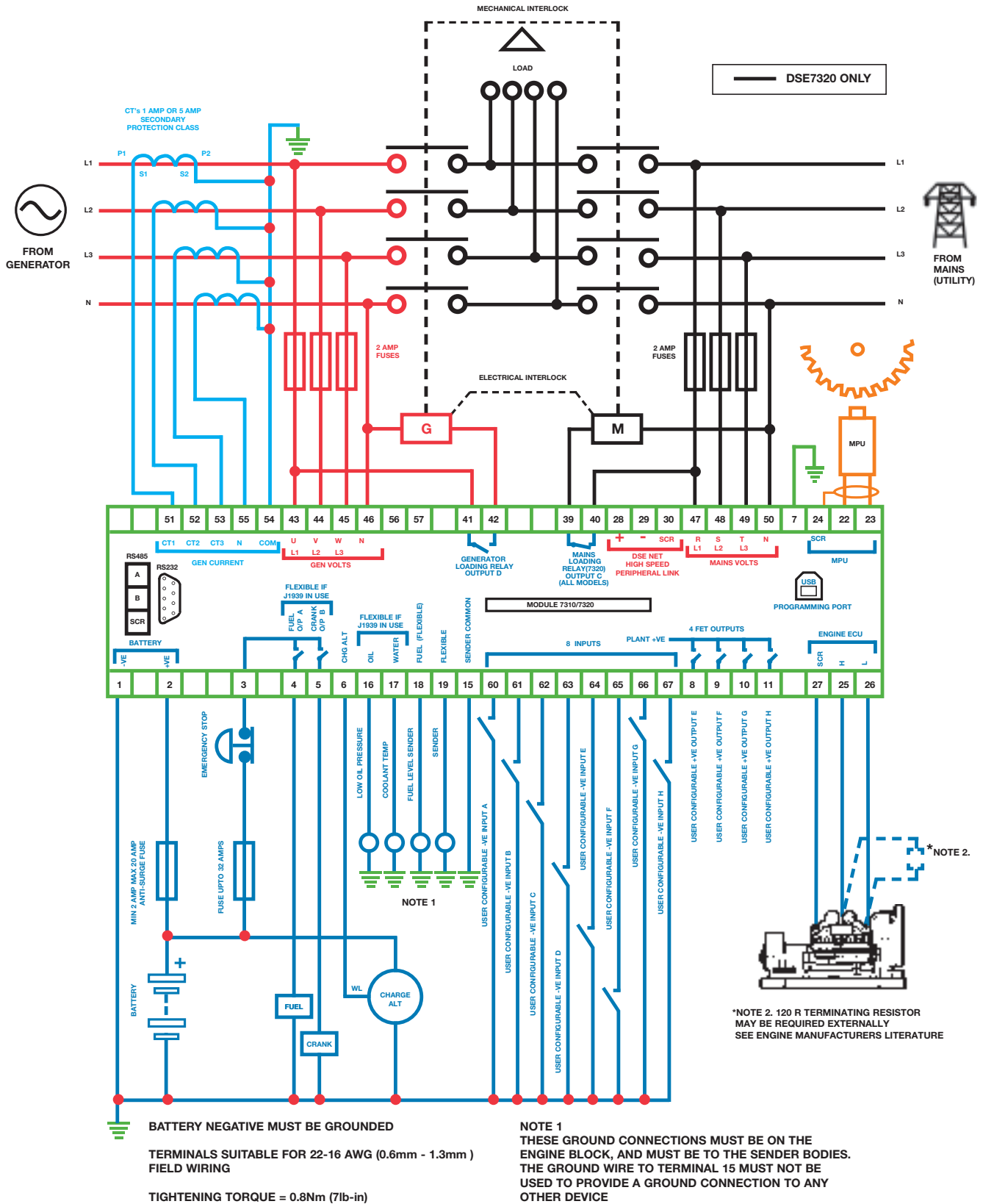

DEEP SEA ELECTRONICS PLC

Highfield House
Hunmanby Industrial Estate
Hunmanby, North Yorkshire
YO14 0PH England

TELEPHONE

+44 (0)1723 890099

FACSIMILE

+44 (0)1723 893303

EMAIL

sales@deepseapl.com

WEBSITE

www.deepseapl.com



Registered in England & Wales No.01319649

VAT No.316923457

DEEP SEA ELECTRONICS INC

3230 Williams Avenue
Rockford
IL 61101-2668 USA

TELEPHONE

+1 (815) 316 8706

FACSIMILE

+1 (815) 316 8708

EMAIL

sales@deepseausa.com

WEBSITE

www.deepseausa.com

YOUR LOCAL DISTRIBUTOR.

DEEP SEA ELECTRONICS PLC maintains a policy of continuous development and reserves the right to change the details shown on this data sheet without prior notice. The contents are intended for guidance only.

This data sheet is printed on 9lives 55 Silk, which is produced with 55% recycled fibre from both pre and post-consumer sources, together with 45% virgin ECF fibre.

