

### Remote Control Panel

Remote control panel was designed to include, in only one single panel, all switches, control devices and protection devices.

Components are the following :

- Engine cut-off module for automatic stop in case of high water temperature, low oil pressure and high alternator temperature.
- Hour-meter.
- Start-stop button.
- Breaker for protection against overload and short circuit.
- Thermal switch for D.C. electric circuit.

### Engine

- Easy access for maintenance to feeding system, lubrication, sea/water pump and air filter.
- Easy access to Oil and fuel filters.
- Safety stop in case of low oil pressure.
- Safety stop in case of high water/exhaust gas temperature.

### Alternator

- Synchronous, 4 poles, self-excited with AVR.
- Rotor and stator coated with epoxy resin against external agents.
- Rotor dynamically balanced.
- Insulation class H.

### Engine

50 Hz

Model	Yanmar 4TNV88
Type	Diesel 4 stroke
Cylinders (nr.)	4
Cylinder block material	Cast iron
Bore (mm - in.)	88 - 3,46
Stroke (mm - in.)	90 - 3,54
Displacement (cc - cu.in.)	2190 - 134
Power (hp)	24,1
Rated rpm	1500
Combustion system	direct
Engine head material	Cast iron
Speed governor	Centrifugal mechanical
Lubrication system	Forced
Oil sump capacity (L - qt.)	5,8 - 6,1
Engine stop system	Stop solenoid
Fuel pump	Electric
Fuel pump discharge (cm - in.)	80 - 31,5
Full load consumption (L/h - gal/h)	5,6 - 1,5
Starting battery (Ah-V)	80 - 12
Battery charger (Ah-V)	40 - 12
Starter (kW-V)	1,2 - 12
Max. inclination	30°
Water pump flow (L/min - gal/min)	25 - 6,6

### Alternator

50 Hz

Type	Synchronous, 4-poles, self-excited
Cooling	Air
Voltage (V)*	400
Frequency (Hz)	50
Current (A)	27,7
Max. power (kVA)	19,2
Continuous power (kVA)	17,4
Power factor ( cos $\phi$ )	0,8
Insulating class	H
Voltage stability	$\pm 2\%$
Frequency stability	$\pm 5\%$

\*Further voltages available on request

### Cooling system

The cooling of the engine is based on a closed inner flow of coolant. The coolant system has a cupronickel heat exchanger seawater/coolant type, where the thermal exchange occurs between coolant and seawater. Two separate pumps push the flow of coolant and sea water.

Dimensions (Leng. x Width x Height)	1000 x 570 x 670 mm
	39,4 x 22,4 x 26,4 in.
Weight	350 kg , 770 lb

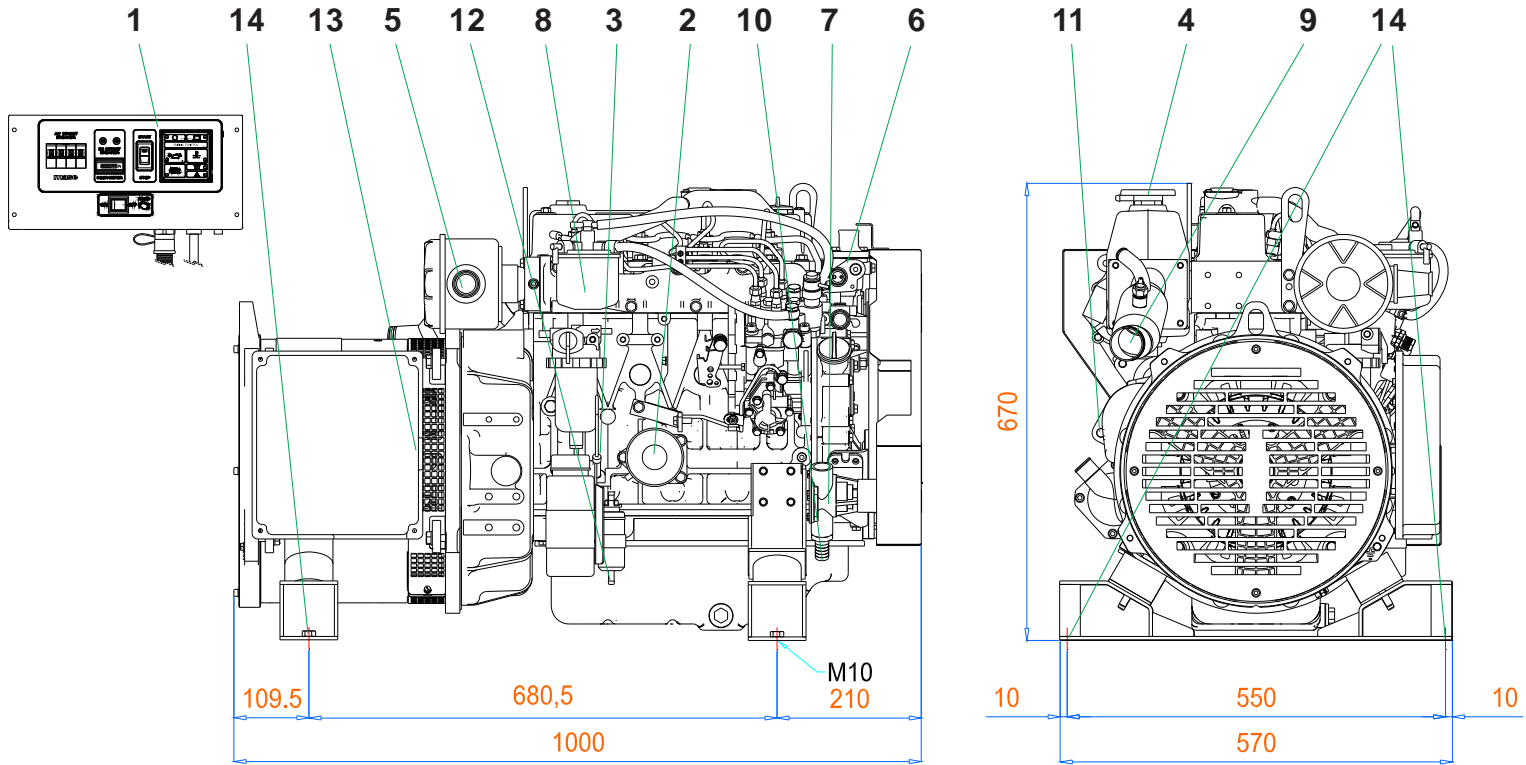

- |                                 |  |
|---------------------------------|--|
| 1 - Control panel               | 8 - Fuel filter                          |
| 2 - Engine oil filter cartridge | 9 - Seawater exhaust connection (ø 50mm) |
| 3 - Oil dipstick                | 10 - Seawater inlet (ø 16mm)             |
| 4 - Engine oil cap              | 11 - Battery connection                  |
| 5 - Air filter                  | 12 - Fuel tank connection (ø 8mm)        |
| 6 - Closed circuit water pump   | 13 - Electric cables outlet              |
| 7 - Seawater pump               | 14 - Fixing stirrups                     |

## FITTINGS

EXHAUST COMPONENTS KIT

SIPHON BREAK

WATER-GAS SEPARATOR KIT

STARTING REMOTE CONTROL PANEL WITH INSTRUMENTS

*This drawing is only a reference and is not indicated for the installation. For more information, you may contact your local dealer or **mase generators S.p.A.***

***mase generators S.p.A.** reserves the right to change the design or specifications without notice and without any obligations or liability whatsoever. For more information, you may contact your local **mase** dealer.*

Dealer: