



# GENERATING SET GE 8 YSXC

The images are for reference



## FEATURES

- The rounded edges of the canopy designed for rainwater drainage away
- Engine cowling side, can be completely opened, which facilitates all maintenance operations
- The recessed control panel is lockable and houses the sockets and machine
- Central lifting eye
- Supersilenced
- Ready for connection to automatic transfer unit EAS (AMF + ATS)
- Meets EC directives for noise and safety



water cooled



diesel



single-phase power



electric start



super silenced

## POWER RATINGS

	WITHOUT AVR	WITH AVR
* Stand-By single-phase power	8 kVA (7.2 kW) 230V / 34.8A	7.5 kVA (6 kW) 230V /32.6A
* PRP single-phase power	7.5 kVA(6.7 kW) 230V /32.6A	7 kVA (5.6 kW) 230V /30.4A
* COP single-phase power	/	
Frequency	50 Hz	
Cos φ	0.8	0.9

\* Output powers according to ISO 8528-1

## DEFINITION

Valid declared powers up to the followings environmental conditions: temperature 25°C, altitude 100 meters above sea level

**LTP power: stand-by power:** Maximum available power for use with variable loads for a yearly number of hours limited at 500 h. No overload is admitted.

**PRP power:** continue power with variable loads. Maximum power for use with variable loads for a yearly illimited nubers of hours.

**COP power:** continuous power with constant load. Maximum power for use with constant loads for a yearly unlimited numbers of hours.

## ENGINE 1500 RPM

### 4 STROKE, INDIRECT INJECTION, NATURAL ASPIRATED

Model	YANMAR 3TNV80
* Stand-By net power	9 kW (12.2 hp)
* PRP net power	8.2 kW (11.1 hp)
* COP net power	/
Cylinders / Displacement	3/ 1.2 lit
Bore / Stroke	80 / 84 (mm)
Compression ratio	23 : 1
BMEP (Brake Mean Effective Pressure : LTP - PRP)	/
Speed governor type	Mechanical
<b>FUEL CONSUMPTION</b>	
110 % (Stand-by power)	2.7 lit./h
100 % to PRP	2.5 lit./h
75 % to PRP	2 lit./h
50 % to PRP	1.6 lit./h
<b>COOLING SYSTEM</b>	
Total system cap. - only engine	/ lit. - 0.9 lit.
Fan air flow	32 m <sup>3</sup> /min.
<b>LUBRICATION SYSTEM</b>	
Total oil system capacity	/
Oil capacity in sump	1.6 lit. (min) – 3.4 lit. (max)
Oil consumption at full load	/

\* Output powers according to ISO 3046-1

## EXHAUST SYSTEM

Maximum exhaust gas flow	/
Max. exhaust gas temp.	390 °C
Maximum back pressure	9.8 kPa (0.1 bar)
External diameter exhaust pipe	/
<b>ELECTRICAL SYSTEM</b>	
Starter motor power	1.1 kW
Battery charging alternator cap.	40 A
Cold start	Cold start aid - 15 °C
With cold start aid	/
<b>AIR FILTER</b>	
Combustion air flow	0.75 m <sup>3</sup> /min
<b>HEAT REJECTED AT FULL LOAD</b>	
To exhaust system	/
To water and oil	/
Radiated to room	/
To charge cooler	/



## ALTERNATOR

SYNCHRONOUS, SINGLE-PHASE, SELF-EXCITED, SELF-REGULATED, BRUSHLESS		
	WITHOUT AVR	WITH AVR
Continuous power	8 kVA	7 kVA
Stand-by power	8.8 kVA	7.1 kVA
Three phase voltage	230 /115 Vac 230 Vac	
Frequency	50 Hz	
Cos φ	1	0.8
Model A.V.R.	/	HVR-10 KE
Voltage regulation acc.	± 5 %	± 1 %
Sustained short circuit current	3 In	
Transient dip (100% load)	10 %	17 %
Recovery time	/	
Efficiency at 100% load	79% (230V - Cos φ 1)	84.4% (400V - Cos φ 0.8)
Insulation	Class H	
Connection - Terminals	Serie - N°4	Triangle - N°6
Electromagnetic compatibility (R.F.I. suppr.)	/	
Waveform distortion - THD	< 5 %	< 4 %
Telephone interference - THF	/	

REACTANCES (8 kVA - 230/115V)		
REACTANCES AVR (7 kVA - 230V)		
Direct axis synchronous - Xd	/	220 %
Direct axis transient - X'd	/	18 %
Subdirect axis transient - X''d	/	7.6 %
Quadrature axis synchronous - Xq	/	119 %
Quadr. axis subtransient - X''q	/	
Negative sequence - X2	/	
Zero sequence - X0	/	
TIME CONSTANTS		
Transient - T'd	/	0.027 sec
Subtransient - T''d	/	0.005 sec
Open circuit - T'do	/	0.335 sec
Armature - Ta	/	
Short-circuit ratio Kcc	/	0.81
IP protection degree	IP 23	
Cooling air flow	0.085 m³/sec.	0.068 m³/sec.
Coupling   Bearing	Direct SAE 5 -7 ½ - N°1	

## GENERAL SPECIFICATIONS

Fuel tank capacity	30 lt.
Running time (75% to PRP)	15 h
Starter battery	12 Vdc -62Ah / 570A CCA(EN)
IP protection degree	IP 23

* Measured acoustic power LwA (pressure LpA)	87 dB(A) (62 dB(A) @ 7 m)
* Guaranteed acoustic power LwA (pressure LpA)	88 dB(A) (63 dB(A) @ 7 m)
Performance class (ISO 8528)	G2

\* Acoustic power according to European Directive 2000/14/CE

## CONTROL PANEL

- EP6 controller
- Fuel level indicator
- Emergency stop button
- Local-Remote Start switch
- EAS connector
- Connector for remote control TCM 35
- Circuit breaker
- ELCB-GFI (Ground Fault Interruptor)
- Magnetothermic switch for 230V 16A socket
- Output socket: 1x 230V 32A 2P + T CEE  
1x 230V 16A 2P + T CEE  
1x 230V 16A 2P + T SCHUKO
- Earth terminal (PE)

### EP6 CONTROLLER CHARACTERISTICS

Operating mode	OFF - MAN. - AUTO
Display	4-digits display
LEDs	Engine is running AUTO mode
Buttons/controls	Starter key AUTO button N° 5 buttons for controller programming
Measures	Generator voltage Generator current Frequency Engine speed Battery voltage Charger battery voltage Hourmeter
Alarms	Low oil pressure High temperature Belt break Low level fuel Emergency stop button Starting failure Over-under generator voltage Over-under frequency Over-under speed High-low battery voltage Overload generator Internal memory failure
Functions	Remote starting (only to AUTO) Cold start aid Automatic periodic test (only to AUTO) Generator contactor control

# WEIGHT - DIMENSIONS AND ACCESSORIES

GE 8 YSXC



### DRY WEIGHT MACHINE:

- 400 kg

Generating set pictured may include optional accessories.



### DIMENSIONS DRAW (mm)

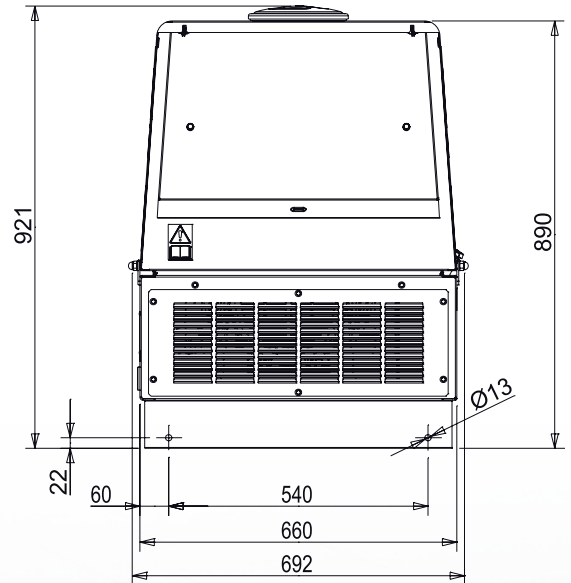
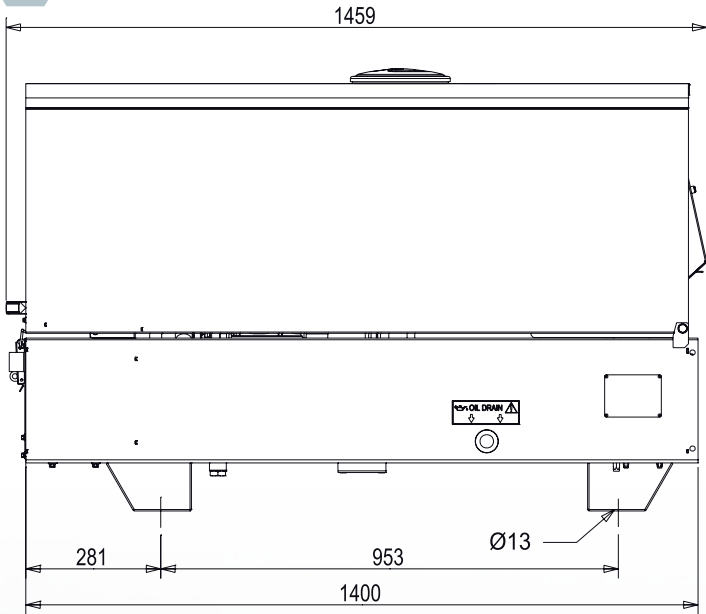

### OPTIONS ON REQUEST

- Automatic transfer unit EAS 17 - 809 (25 A)
- Remote control TCM35
- Locking Fuel Cap
- Site tow CTL300
- Road trailer CTV4
- Earthing kit

### VERSIONS ON REQUEST

- AVR version

### FACTORY INSTALLATION OPTIONS

- Engine water heater WH
- Radio control

## GENERAL INFORMATION

### COMPLIANCE GENERATING SETS WITH EC DIRECTIVES AND STANDARDS

- 2006/42 / EC (Machines Directive)
- 2014/35 / EU (Low Voltage Directive)
- 2014/30 / EU (EMC Directive)
- 2000/14 / EC (Directive Acoustic Emission for machines for use outdoors)
- ISO 8528 (Reciprocating internal combustion engine driven alternating current generating sets)



ISO 9001:2008 - Cert. 0192

### WARRANTY

All devices are covered by the manufacturer's warranty.

The company reserves the right to change this specification without notice. For further information please contact the sales department.

© MOSA - Viale Europa, 59 - 20090 Cusago (Milano) - Italy - phone +39-0290352.1 - fax + 39-0290390466 E-mail: info@mosa.it Web site: www.mosa.it

