

TS 350 YSX BC

0 5 1 0

873819003 - GB

USE AND MAINTENANCE MANUAL SPARE PARTS CATALOG

Main Characteristics of the unit:

- Welding control with bridge at 6 controle diodes
- Maximum welding current 350A
- Three-phase power generation 12 kVA / single-phase 7 kVA
- Diesel engine Yanmar 3TNV76
- Noise level at 7m 67dBA
- Dimensions / weight: 1610x720x1110 / 535 Kg.

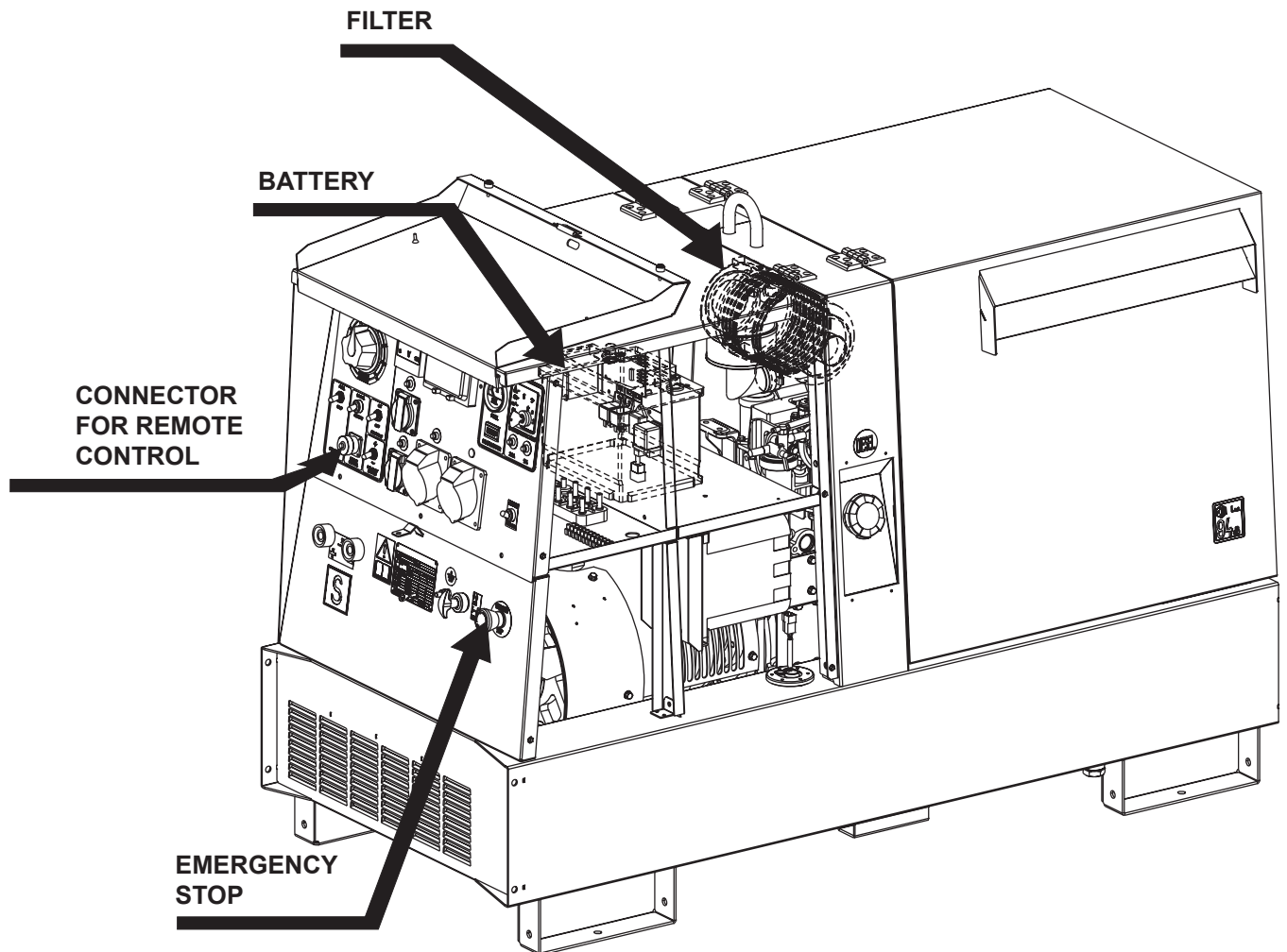

The engine driven welder TS 350 YSX has been completely renovated in comparison to the previous model, without increasing the length and width of the machine. The height has been increased instead, to improve the access to the electrical box and to counteract, in a more efficient manner, the engine noise. The base of the machine includes the tank, while the loading is obtained from the roll bar without protrusion from the base.

UNI EN ISO 9001 : 2000

ISO 9001:2000 - Cert. 0192

MOSA has certified its quality system according to UNI EN ISO 9001:2000 to ensure a constant, high quality of its products. This certification covers the design, production and servicing of engine driven welders and generating sets.

The certifying institute, ICIM, which is a member of the International Certification Network IQNet, awarded the official approval to MOSA after an examination of its operations at the head office and plant in Cusago (MI), Italy.

This certification is not a point of arrival but a pledge on the part of the entire company to maintain a level of quality of both its products and services which will continue to satisfy the needs of its clients, as well as to improve the transparency and the communications regarding all the company's activities in accordance with the official procedures and in harmony with the MOSA Manual of Quality.

The advantages for MOSA clients are:

- Constant quality of products and services at the high level which the client expects;
- Continuous efforts to improve the products and their performance at competitive conditions;
- Competent support in the solution of problems;
- Information and training in the correct application and use of the products to assure the security of the operator and protect the environment;
- Regular inspections by ICIM to confirm that the requirements of the company's quality system and ISO 9001 are being respected.

All these advantages are guaranteed by the CERTIFICATE OF QUALITY SYSTEM No.0192 issued by ICIM S.p.A. - Milano (Italy) - www.icim.it

M 01	QUALITY SYSTEM
M 1.01	COPYRIGHT
M 1.1	NOTES
M 1.4	CE MARK
M 1.5	TECHNICAL DATA
M 1.6	TECHNICAL DATA ENGINE DRIVEN WELDER
M 2-2.1	SYMBOLS AND SAFETY PRECAUTIONS
M 2.5...	INSTALLATION AND ADVICE BEFORE USE
M 2.6	INSTALLATIONS AND ADVICE
M 2.7	INSTALLATION
M 3	PACKING
M 4...	TRANSPORT AND DISPLACEMENTS
M 6...	ASSEMBLY: CT.....
M 20	SETTING-UP THE UNIT (DIESEL ENGINE)
M 21	ENGINE STARTING AND USE (DIESEL ENGINE)
M 22	STOPPING THE ENGINE (DIESEL ENGINE)
M 25	SETTING-UP THE UNIT (GASOLINE ENGINE)
M 26	STARTING THE ENGINE (GASOLINE ENGINE)
M 27	STOPPING THE ENGINE (GASOLINE ENGINE)
M 30	CONTROLS LEGEND
M 31	CONTROLS
M 34	USE AS A WELDER
M 35	USE AS AN ENGINE STARTER
M 36	USE AS A BATTERY CHARGE
M 37...	USE AS A GENERATOR
M 38...	USE OF THE REMOTE CONTROL
M 39...	USE OF THE ENGINE PROTECTION
M 40...	TROUBLE SHOOTING
M 43...	MAINTENANCE
M 45	STORAGE
M 46	CAST OFF
M 53	DIMENSIONS
M 55	RECOMMENDED ELECTRODES
M 60	ELECTRICAL SYSTEM LEGENDE
M 61...	ELECTRICAL SYSTEM
R 1	SPARE PARTS LIST
.....	SPARE PARTS
K...	ACCESSORIES



ATTENTION

This use and maintenance manual is an important part of the machines in question.

The assistance and maintenance personnel must keep said manual at disposal, as well as that for the engine and alternator (if the machine is synchronous) and all other documentation about the machine.

We advise you to pay attention to the pages concerning the security (see page M1.1).



© All rights are reserved to said Company.

It is a property logo of MOSA division of B.C.S. S.p.A. All other possible logos contained in the documentation are registered by the respective owners.

▄▄▄▄▶ The reproduction and total or partial use, in any form and/or with any means, of the documentation is allowed to nobody without a written permission by MOSA division of B.C.S. S.p.A.

To this aim is reminded the protection of the author's right and the rights connected to the creation and design for communication, as provided by the laws in force in the matter.

In no case MOSA division of B.C.S. S.p.A. will be held responsible for any damage, direct or indirect, in relation with the use of the given information.

MOSA division of B.C.S. S.p.A. does not take any responsibility about the shown information on firms or individuals, but keeps the right to refuse services or information publication which it judges discutible, unright or illegal.

INFORMATION

Dear Customer,
We wish to thank you for having bought from MOSA a high quality set.

Our sections for Technical Service and Spare Parts will work at best to help you if it were necessary.

To this purpose we advise you, for all control and overhaul operations, to turn to the nearest authorized Service Centre, where you will obtain a prompt and specialized intervention.

- ☞ In case you do not profit on these Services and some parts are replaced, please ask and be sure that are used exclusively original MOSA parts; this to guarantee that the performances and the initial safety prescribed by the norms in force are re-established.
- ☞ **The use of non original spare parts will cancel immediately any guarantee and Technical Service obligation from MOSA.**

NOTES ABOUT THE MANUAL

Before actioning the machine please read this manual attentively. Follow the instructions contained in it, in this way you will avoid inconveniences due to negligence, mistakes or incorrect maintenance. The manual is for qualified personnel, who knows the rules: about safety and health, installation and use of sets movable as well as fixed.

You must remember that, in case you have difficulties for use or installation or others, our Technical Service is always at your disposal for explanations or interventions.

The manual for Use Maintenance and Spare Parts is an integrant part of the product. It must be kept with care during all the life of the product.

In case the machine and/or the set should be yielded to another user, this manual must also given to him.

Do not damage it, do not take parts away, do not tear pages and keep it in places protected from dampness and heat.

You must take into account that some figures contained in it want only to identify the described parts and therefore might not correspond to the machine in your possession.

INFORMATION OF GENERAL TYPE

In the envelope given together with the machine and/or set you will find: the manual for Use Maintenance and Spare Parts, the manual for use of the engine and the tools (if included in the equipment), the guarantee (in the countries where it is prescribed by law).

Our products have been designed for the use of generation for welding, electric and hydraulic system; ANY OTHER DIFFERENT USE NOT INCLUDED IN THE ONE INDICATED, relieves MOSA from the risks which could happen or, anyway, from that which was agreed when selling the machine; MOSA excludes any responsibility for damages to the machine, to the things or to persons in this case.

Our products are made in conformity with the safety norms in force, for which it is advisable to use all these devices or information so that the use does not bring damage to persons or things.

While working it is advisable to keep to the personal safety norms in force in the countries to which the product is destined (clothing, work tools, etc.).

Do not modify for any motive parts of the machine (fastenings, holes, electric or mechanical devices, others..) if not duly authorized in writing by MOSA: the responsibility coming from any potential intervention will fall on the executioner as in fact he becomes maker of the machine.

- ☞ **Notice:** *this manual does not engage MOSA, who keeps the faculty, apart the essential characteristics of the model here described and illustrated, to bring betterments and modifications to parts and accessories, without putting this manual uptodate immediately.*



Any of our product is labelled with CE marking attesting its conformity to appliable directives and also the fulfillment of safety requirements of the product itself; the list of these directives is part of the declaration of conformity included in any machine standard equipment. Here below the adopted symbol:



CE marking is clearly readable and unerasable and it can be either part of the data-plate (A) or placed as a sticker near the data-plate (B)

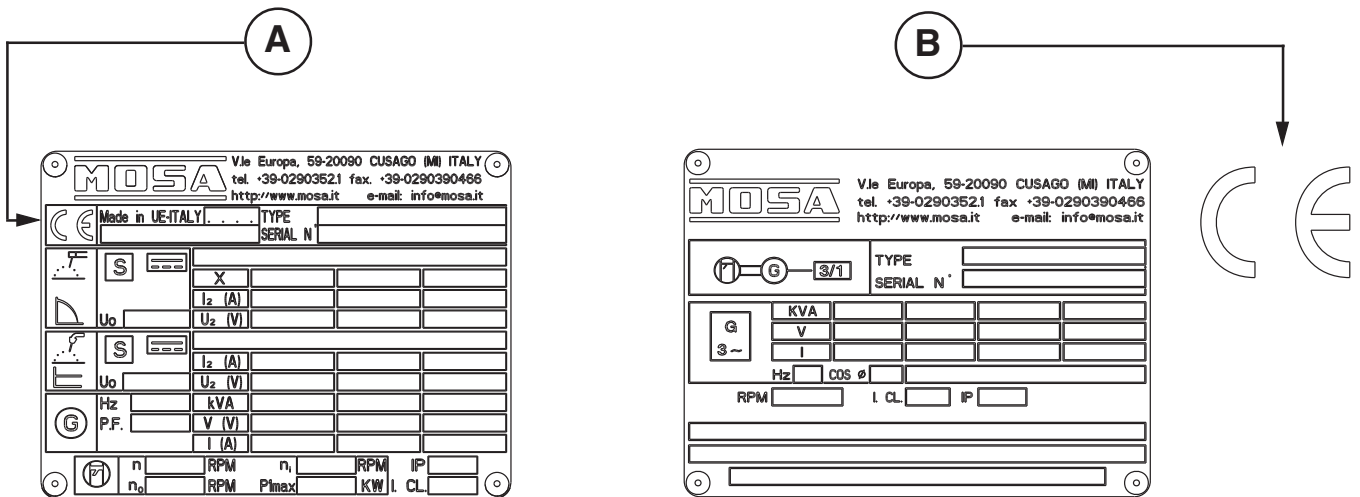

Furthermore, on each model it is shown the noise level value; the symbol used is the following:

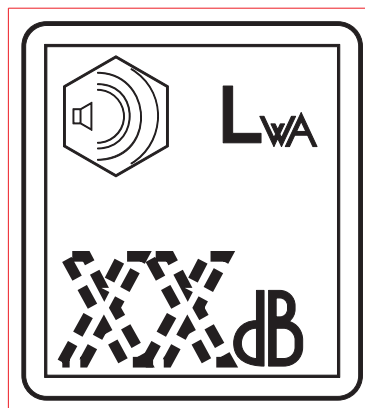

The indication is shown in a clear, readable and indeleble way on a sticker.

The TS 350 engine driven welder is a unit which ensures the function as:

- a) a current source for arc welding
- b) a current source for the auxiliary power generation

It is meant for industrial and professional use, powered by an endothermic engine; it is composed of various main parts such as: engine, alternator, electric and electronic controls, the fairing or a protective structure.

The assembling is made on a steel structure, on which are provided elastic support which must damp the vibrations and also eliminate sounds which would produce noise.

Technical data TS 350 YSX BC

GENERATOR	
Three-phase generation	12 kVA / 400 V / 17.3 A
Single-phase generation	7 kVA / 230 V / 30.4 A
Single-phase generation	3.5 kVA / 110 V cte / 31.8 A
Frequency	50 Hz
ALTERNATOR	
	self-excited, self-regulated, brushless
Type	three-phase, asynchronous
Insulating class	H
ENGINE	
Mark / Model	YANMAR / 3TNV76
Type/Cooling system	Diesel 4-Stroke / Liquid
Cylinders/ Displacement	3 / 1116 cm ³
Net power	16.5 kW (25.4 HP)
Speed	3000 rpm
Fuel consumption (welding 60%)	3.4 l/h
Cooling system capacity	4 l
Engine oil capacity	4 l
Starter	Electric
GENERAL SPECIFICATIONS	
Battery	12V - 60Ah
Tank capacity	45 l
Running time (welding 60%)	13 h
Protection	IP 23
Dimensions / max. Lxwxh (mm) *	1610x720x1110
Weight *	535 Kg
Measured acoustic power L _{wA} (pressure L _{pA})	92 dB(A) (67 dB(A) @ 7m)
Guaranteed acoustic power L _{wA} (pressure L _{pA})	93 dB(A) (68 dB(A) @ 7m)



* Dimensions and weight are inclusive of all parts without wheels and towbar

POWER

Declared power according to ISO 3046-1 (temperature 25°C, 30% relative humidity, altitude 100 m above sea level).

It's admitted overload of 10% each hour every 12 h.

In an **approximative** way one reduces: of 1% every 100 m altitude and of 2.5% for every 5°C above 25°C.

ACOUSTIC POWER LEVEL

ATTENTION: The concrete risk due to the machine depends on the conditions in which it is used. Therefore, it is up to the end-user and under his direct responsibility to make a correct evaluation of the same risk and to adopt specific precautions (for instance, adopting a I.P.D. -Individual Protection Device)

Acoustic Noise Level (L_{wA}) - Measure Unit dB(A): it stands for acoustic noise released in a certain delay of time. This is not submitted to the distance of measurement.

Acoustic Pressure (L_p) - Measure Unit dB(A): it measures the pressure originated by sound waves emission. Its value changes in proportion to the distance of measurement.

The here below table shows examples of acoustic pressure (L_p) at different distances from a machine with Acoustic Noise Level (L_{wA}) of 95 dB(A)

L_p a 1 meter = 95 dB(A) - 8 dB(A) = 87 dB(A)

L_p a 7 meters = 95 dB(A) - 25 dB(A) = 70 dB(A)

L_p a 4 meters = 95 dB(A) - 20 dB(A) = 75 dB(A)

L_p a 10 meters = 95 dB(A) - 28 dB(A) = 67 dB(A)

PLEASE NOTE: the symbol  when with acoustic noise values, indicates that the device respects noise emission limits according to 2000/14/CE directive.

D.C. WELDING

Service 350 A - 35%, 320 A - 60%, 270A - 100%
 Current range, continuous 20 - 350 A
 Striking voltage 65 V

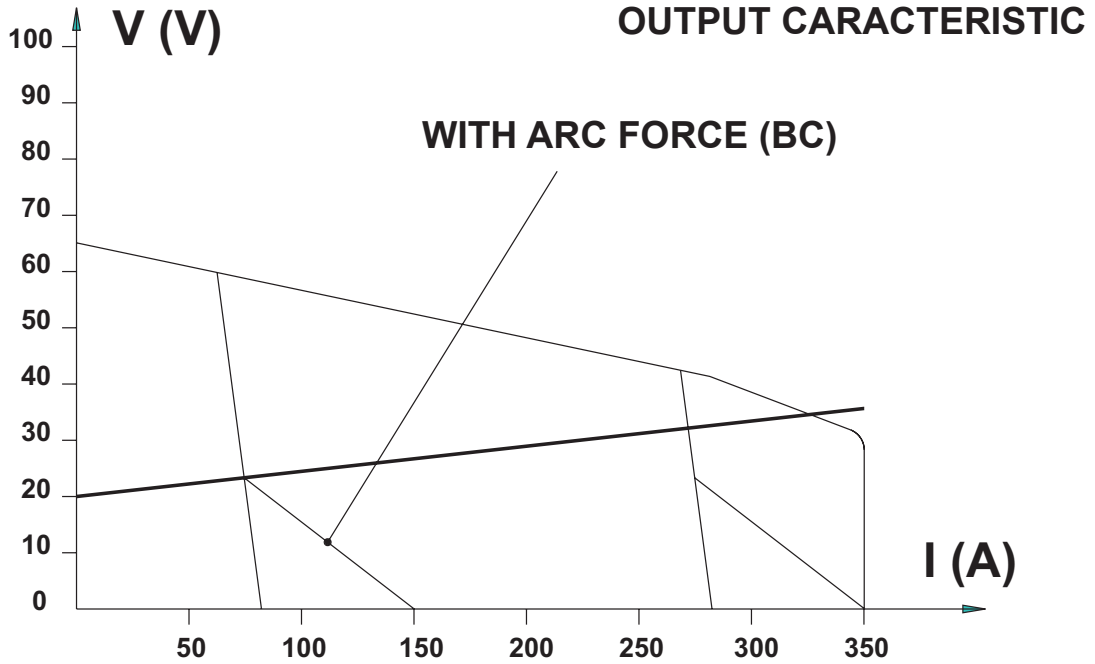

SIMULTANEOUS UTILIZATION FACTORS

In case **Welding** and **Generation** can be used simultaneously, however, the engine **cannot** be overloaded. The table below gives the maximum limits to be respected:

WELDING CURRENT	350 A	175 A	150 A	100 A	0
AUXILIARY POWER	0	1.5 kVA	4 kVA	8 kVA	12 kVA

SYMBOLS IN THIS MANUAL

- The symbols used in this manual are designed to call your attention to important aspects of the operation of the machine as well as potential hazards and dangers for persons and things.

IMPORTANT ADVICE

- Advice to the User about the safety:

-  N.B.: The information contained in the manual can be changed without notice. Potential damages caused in relation to the use of these instructions will not be considered because these are only indicative. Remember that the non observance of the indications reported by us might cause damage to persons or things. It is understood, that local dispositions and/or laws must be respected.

WARNING



Situations of danger - no harm to persons or things

Do not use without protective devices provided

Removing or disabling protective devices on the machine is prohibited.

Do not use the machine if it is not in good technical condition

The machine must be in good working order before being used. Defects, especially those which regard the safety of the machine, must be repaired before using the machine.

SAFETY PRECAUTIONS

**DANGEROUS**

This heading warns of an immediate danger for persons as well for things. Not following the advice can result in serious injury or death.

**WARNING**

This heading warns of situations which could result in injury for persons or damage to things.

**CAUTION**

To this advice can appear a danger for persons as well as for things, for which can appear situations bringing material damage to things.

**IMPORTANT****NOTE****ATTENTION**

These headings refer to information which will assist you in the correct use of the machine and/or accessories.

SYMBOLS



STOP - Read absolutely and be duly attentive



Read and pay due attention



GENERAL ADVICE - If the advice is not respected damage can happen to persons or things.



HIGH VOLTAGE - Attention High Voltage. There can be parts in voltage, dangerous to touch. The non observance of the advice implies life danger.



FIRE - Danger of flame or fire. If the advice is not respected fires can happen.



HEAT - Hot surfaces. If the advice is not respected burns or damage to things can be caused.



EXPLOSION - Explosive material or danger of explosion. in general. If the advice is not respected there can be explosions.



WATER - Danger of shortcircuit. If the advice is not respected fires or damage to persons can be caused.



SMOKING - The cigarette can cause fire or explosion. If the advice is not respected fires or explosions can be caused.



ACIDS - Danger of corrosion. If the advice is not respected the acids can cause corrosions with damage to persons or things.



WRENCH - Use of the tools. If the advice is not respected damage can be caused to things and even to persons.



PRESSION - Danger of burns caused by the expulsion of hot liquids under pressure.



ACCES FORBIDDEN to non authorizad people.

PROHIBITIONS No harm for persons

Use only with safety clothing -



It is compulsory to use the personal protection means given in equipment.

Use only with safety clothing -



It is compulsory to use the personal protection means given in equipment.

Use only with safety protections -



It is a must to use protection means suitable for the different welding works.

Use with only safety material -



It is prohibited to use water to quench fires on the electric machines.

Use only with non inserted voltage -



It is prohibited to make interventions before having disinserted the voltage.

No smoking -



It is prohibited to smoke while filling the tank with fuel.

No welding -



It is forbidden to weld in rooms containing explosive gases.

ADVICE No harm for persons and things

Use only with safety tools, adapted to the specific use -

It is advisable to use tools adapted to the various maintenance works.

Use only with safety protections, specifically suitable



It is advisable to use protections suitable for the different welding works.

Use only with safety protections -



It is advisable to use protections suitable for the different daily checking works.

Use only with safety protections -



It is advisable to use all protections while shifting the machine.

Use only with safety protections -



It is advisable to use protections suitable for the different daily checking works.and/or of maintenance.



The installation and the general advice concerning the operations, are finalized to the correct use of the machine, in the place where it is used as generator group and/or welder.

ENGINE	Stop engine when fueling	CHECKING BOARD	Do not touch electric devices if you are barefoot or with wet clothes.
	Do not smoke, avoid flames, sparks or electric tools when fueling.		Always keep off leaning surfaces during work operations
	Unscrew the cap slowly to let out the fuel vapours.		Static electricity can damage the parts on the circuit.
	Slowly unscrew the cooling liquid tap if the liquid must be topped up.		An electric shock can kill
	The vapor and the heated cooling liquid under pressure can burn face, eyes, skin.		
	Do not fill tank completely.		
	Wipe up spilled fuel before starting engine.		
	Shut off fuel of tank when moving machine (where it is assembled).		
Avoid spilling fuel on hot engine.			
Sparks may cause the explosion of battery vapours			



FIRST AID. In case the operator should be sprayed by accident, from corrosive liquids a/o hot toxic gas or whatever event which may cause serious injuries or death, predispose the first aid in accordance with the ruling labour accident standards or of local instructions.

Skin contact	Wash with water and soap
Eyes contact	Irrigate with plenty of water, if the irritation persists contact a specialist
Ingestion	Do not induce vomit as to avoid the intake of vomit into the lungs, send for a doctor
Suction of liquids from lungs	If you suppose that vomit has entered the lungs (as in case of spontaneous vomit) take the subject to the hospital with the utmost urgency
Inhalation	In case of exposure to high concentration of vapours take immediately to a non polluted zone the person involved



FIRE PREVENTION. In case the working zone, for whatsoever cause goes on fire with flames liable to cause severe wounds or death, follow the first aid as described by the ruling norms or local ones.

EXTINCTION MEANS	
Appropriated	Carbonate anhydride (or carbon dioxide) powder, foam, nebulized water
Not to be used	Avoid the use of water jets
Other indications	Cover eventual shedding not on fire with foam or sand, use water jets to cool off the surfaces close to the fire
Particular protection	Wear an autorespiratory mask when heavy smoke is present
Useful warnings	Avoid, by appropriate means to have oil sprays over metallic hot surfaces or over electric contacts (switches, plugs, etc.). In case of oil sprinkling from pressure circuits, keep in mind that the inflammability point is very low.

WARNING					CAUTION		DANGEROUS

WARNING	THE MACHINE MUST NOT BE USED IN AREAS WITH EXPLOSIVE ATMOSPHERE
----------------	--



INSTALLATION AND ADVICE BEFORE USE

The operator of the welder is responsible for the security of the people who work with the welder and for those in the vicinity.

The security measures must satisfy the rules and regulations for engine driven welders.

The information given below is in addition to the local security norms.

Estimate possible electromagnetic problems in the work area taking into account the following indications.

1. Telephonic wirings and/or of communication, check wirings and so on, in the immediate vicinity.
2. Radio and television receptors and transmettors.
3. Computer and other checking devices.
4. Critical devices for safety and/or for industrial checks.
5. Peapol who, for instance, use pace-maker, hearing-aid for deaf or something and else.
6. Devices used for rating and measuring.
7. The immunity of other devices in the operation area of the welder. Make sure that other used devices are compatible. If it is the case, provide other additional measures of protection.
8. The daily duration of the welding time.



Make sure that the area is safe before starting any welding operation.

- ⚡ Do not touch any bare wires, leads or contacts as they may be live and there is danger of electric shock which can cause death or serious burns. The electrode and welding cables, etc. are live when the unit is operating.
- ⚡ Do not touch any electrical parts or the electrode while standing in water or with wet hands, feet or clothes.
- ⚡ Insulate yourself from the work surface while welding. Use carpets or other insulating materials to avoid physical contact with the work surface and the floor.
- ⚡ Always wear dry, insulating gloves, without holes, and body protection.
- ⚡ Do not wind cables around the body.
- ⚡ Use ear protections if the noise level is high.
- ⚡ Keep flammable material away from the welding area.
- ⚡ Do not weld on containers which contain flammable material.
- ⚡ Do not weld near refuelling areas.
- ⚡ Do not weld on easily flammable surfaces.
- ⚡ Do not use the welder to defrost (thaw) pipes.
- ⚡ Remove the electrode from the electrode holder, when not welding.
- ⚡ Avoid inhaling fumes by providing a ventilation system or, if not possible, use an approved air breather.
- ⚡ Do not work in closed areas where there is no fresh air flow.
- ⚡ Protect face and eyes (protective mask with suitable dark lens and side screens), ears and body (non-flammable protective clothers).



INSTALLATION AND ADVICE BEFORE USE

GASOLINE ENGINES

- ☞ Use in open space, air swept or vent exhaust gases, which contain the deadly carbone oxyde, far from the work area.

DIESEL ENGINES

- ☞ Use in open space, air swept or vent exhaust gases far from the work area.

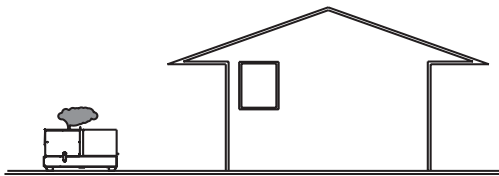
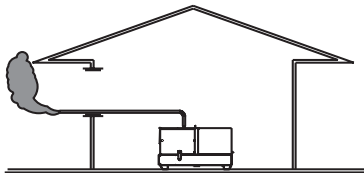
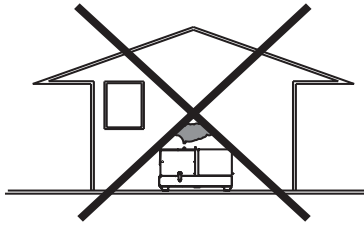

POSITION

Place the machine on a level surface at a distance of at least 1,5 m from buildings or other plants.

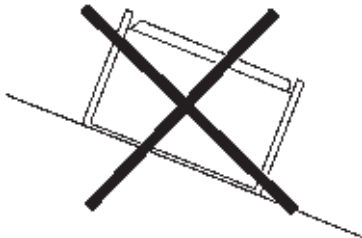

Maximum leaning of the machine (in case of dislevel)

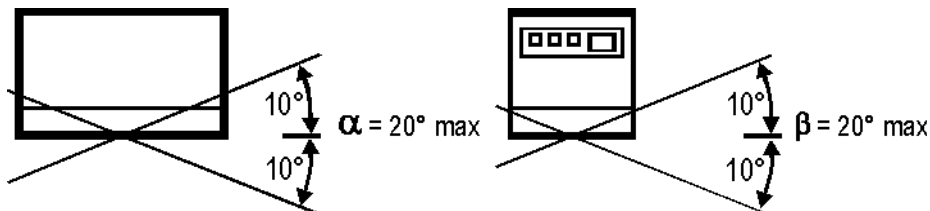

Check that the air gets changed completely and the hot air sent out does not come back inside the set so as to cause a dangerous increase of the temperature.

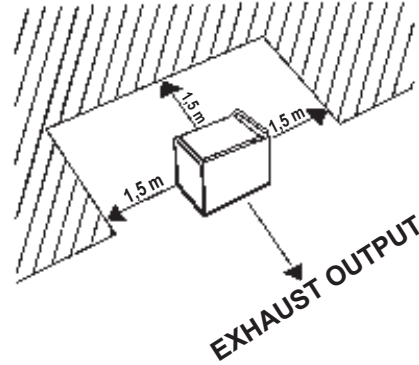

- ☞ Make sure that the machine does not move during the work: **block** it possibly with tools and/or devices made to this purpose.

MOVES OF THE MACHINE

- ☞ At any move check that the engine is **off**, that there are no connections with cables which impede the moves.

PLACE OF THE MACHINE



ATTENTION



For a safer use from the operator **DO NOT** fit the machine in locations with high risk of flood.

Please do not use the machine in weather conditions which are beyond IP protection shown both in the data plate and on page named "technical data" in this same manual.

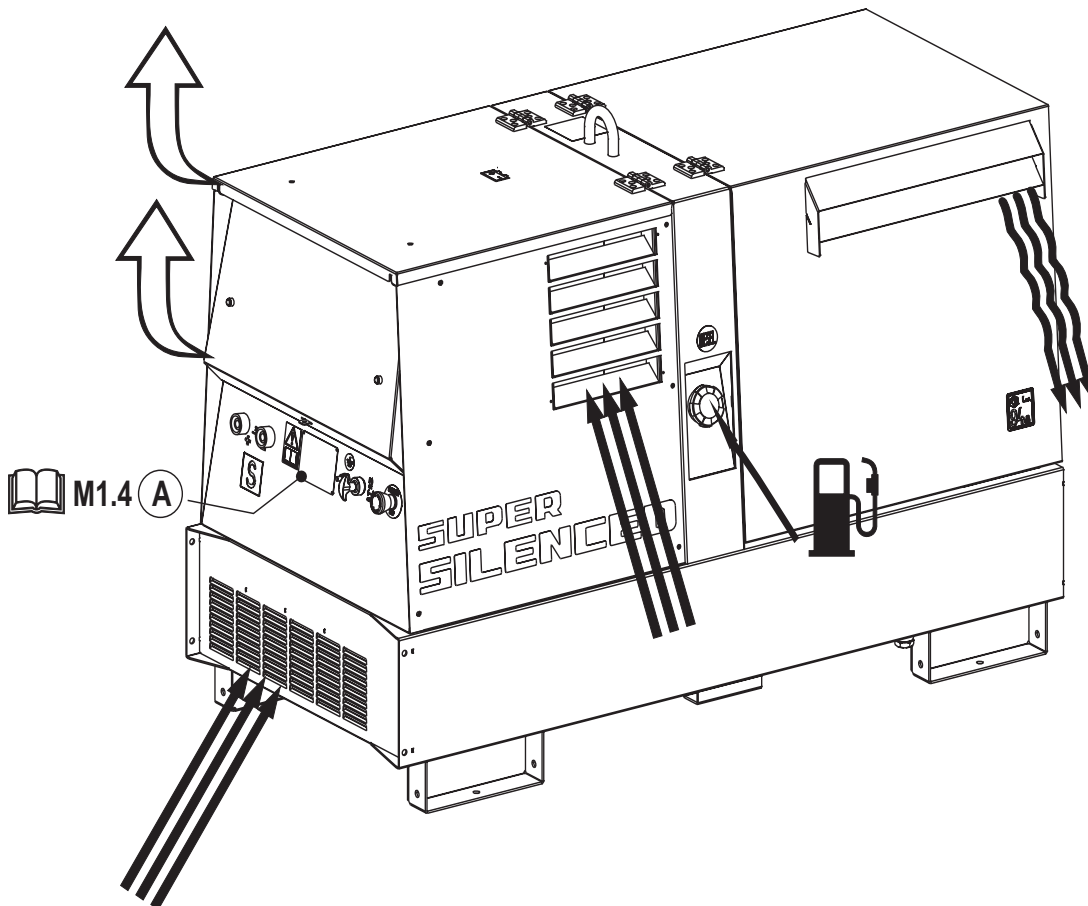
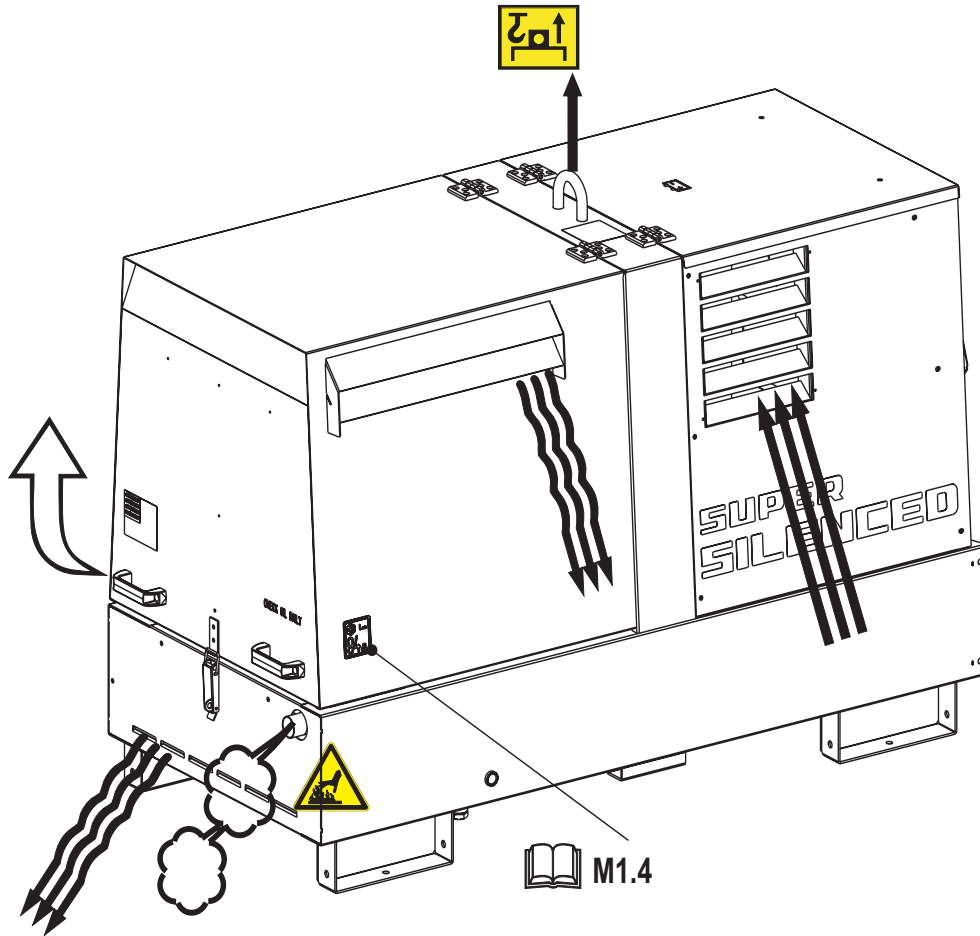



NOTE

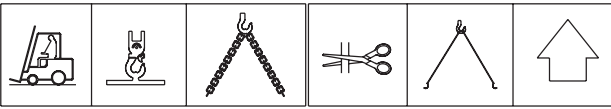

Be sure that the lifting devices are: correctly mounted, adequate for the weight of the machine with its packaging, and conforms to local rules and regulations.

When receiving the goods make sure that the product has not suffered damage during the transport, that there has not been rough handling or taking away of parts contained inside the packing or in the set.

In case you find damages, rough handling or absence of parts (envelopes, manuals, etc.), we advise you to inform immediately our Technical Service.



For eliminating the packing materials, the User must keep to the norms in force in his country.

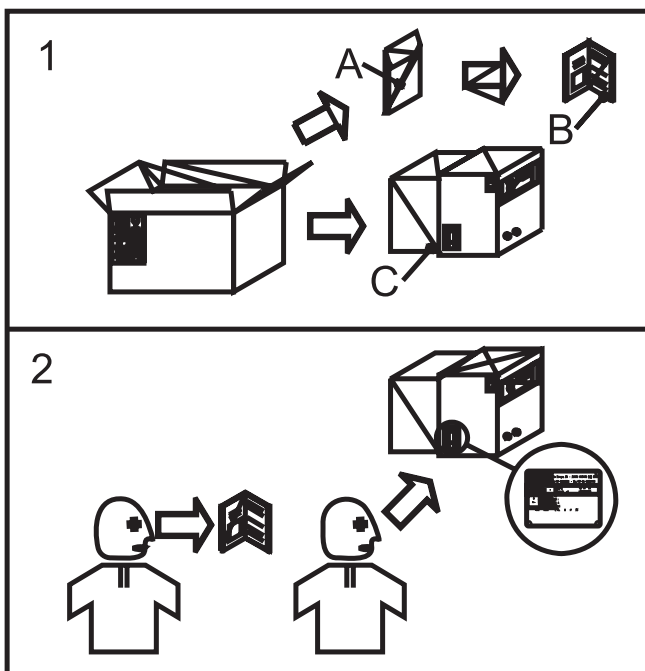
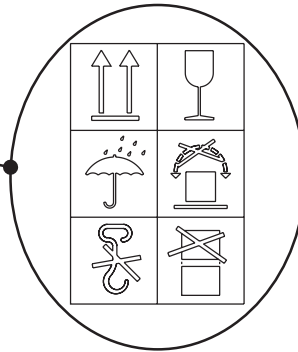
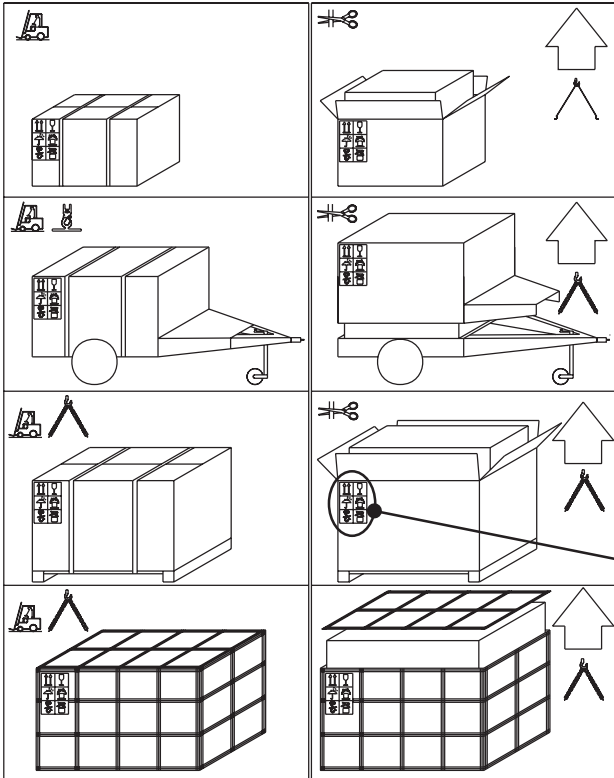

- 1) Take the machine (C) out of the shipment packing. Take out of the envelope (A) the user's manual (B).
- 2) Read: the user's manual (B), the plates fixed on the machine, the data plate.



NOTE

Transportation must always take place with the engine off, electrical cables and starting battery disconnected and fuel tank empty.

Be sure that the lifting devices are: correctly mounted, adequate for the weight of the machine with it's packaging, and conform to local rules and regulations.

Only authorized persons involved in the transport of the machine should be in the area of movement.

DO NOT LOAD OTHER PARTS WHICH CAN MODIFY WEIGHT AND BARICENTER POSITION.

IT IS STRICTLY FORBIDDEN TO DRAG THE MACHINE MANUALLY OR TOW IT BY ANY VEHICLE (model with no CTL accessory).

If you did not keep to the instructions, you could damage the structure of the machine.

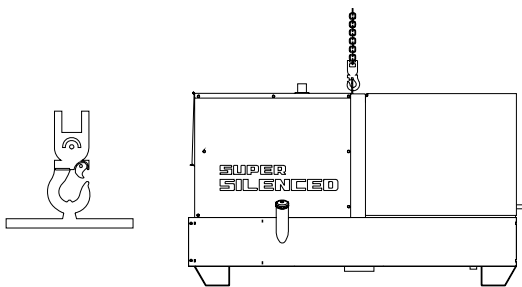
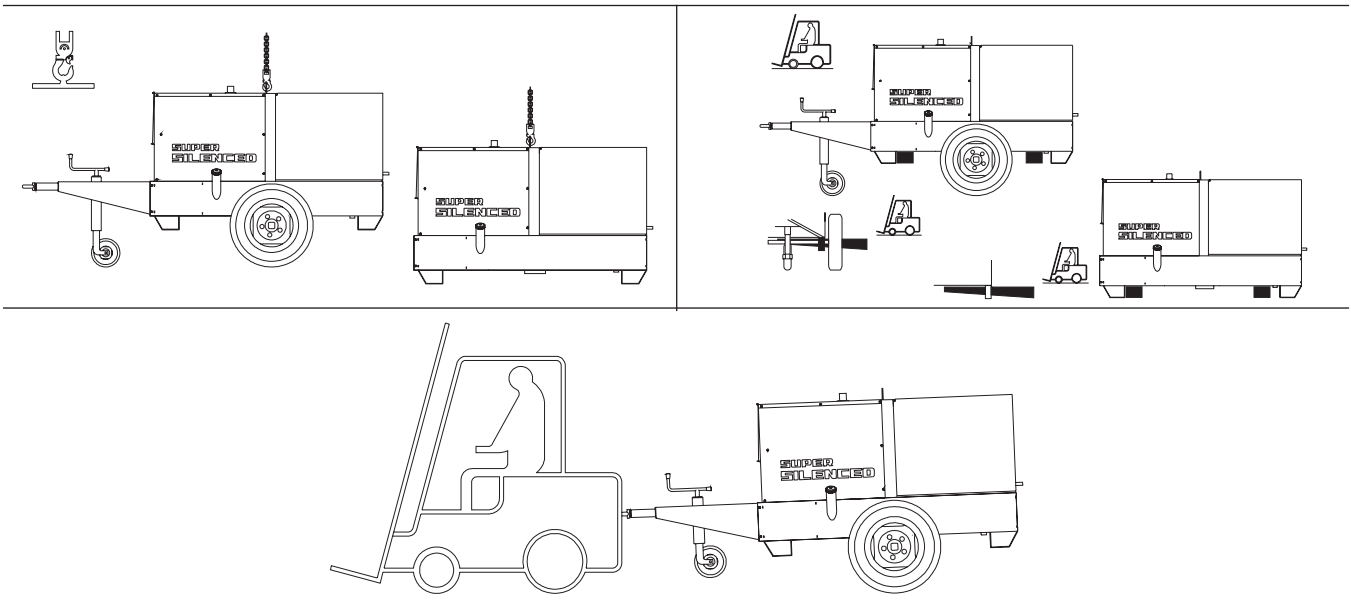

LIFT ONLY THE MACHINE

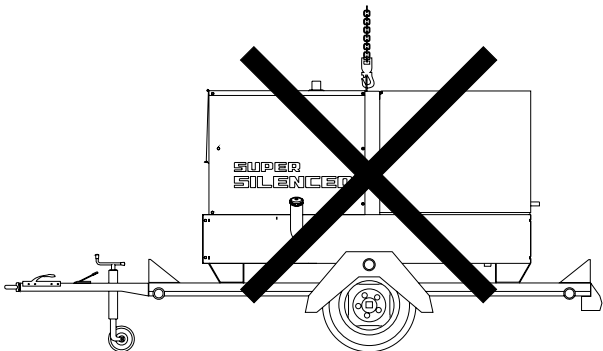

DO NOT LIFT THE MACHINE AND TRAILER



DANGER: LIFTING EYE IS NOT DESIGNED TO SUPPORT ADDED WEIGHT OF ROAD TOW TRAILER





ATTENTION

The CTL accessory cannot be removed from the machine and used separately (actioned manually or following vehicles) for the transport of loads or anyway for used different from the machine movements.

TRAILERS

The machines provided for assembling the CTL accessory (slow towing trolley) can be towed up to a **maximum** speed of **40 Kms/hour** on asphalted surfaces.

Towing on public roads or turnpikes of any type **IS EXCLUDED**, because **not** in possession of the requirements by national and foreign traffic norms.

Nota: Lift the machine and assemble the parts as shown in the drawing

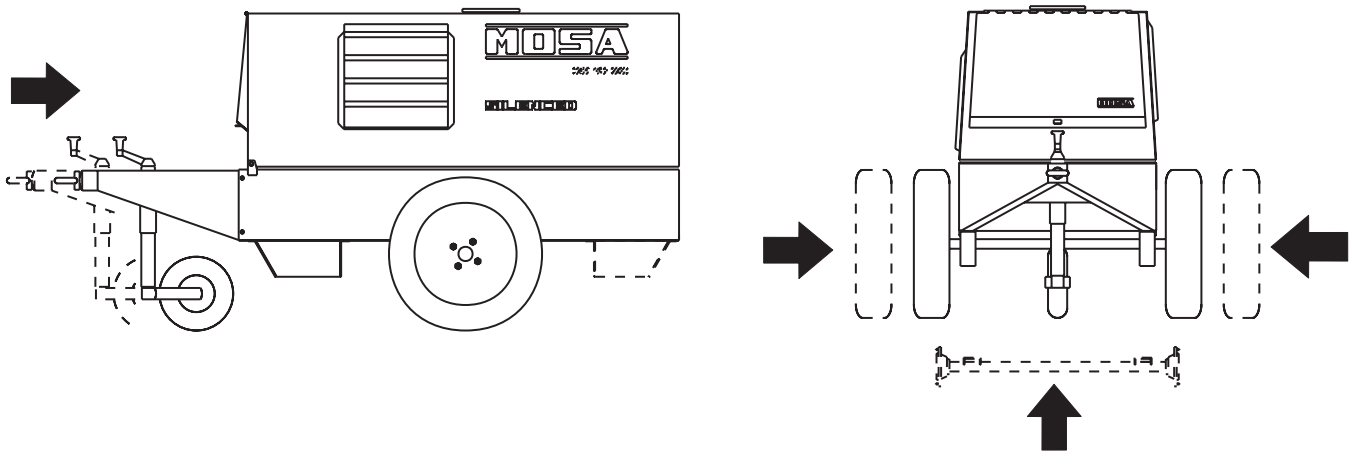

For assembling the generating set on the trolley CTL400 please keep to following instructions:

- 1) - Lift the generating set (by means of suitable hook).
- 2) - Slightly fix the jaw (3) of the parking foot to the bar with the M10x20 screws, the M10 nuts and the washers (so as to let the foot sprag go through).
- 3) - Split (unscrewing them) the two parts of the foot (4S-4I) to be able later to assemble them on the jaw.
- 4) - Introduce into the jaw (3) the upper part (4S) of the foot and screw again the lower part (4I), then tighten the screws (4V) of the jaw to the towbar and block momentarily with the lever (4L) the whole foot.
- 5) - Assemble on the machine the towbar (5) complete of foot with the M10x20 screws, nuts and washers (see fig. page M6.2).
- 6) - Assemble the axle (7) to the base of the machine (see fig. page M6.2) with the M 10x20 screws and relative washers (two per part) so that their supports coincide.
- 8) - Insert the wheel (9) on the axle then screw the self blocking nuts (8).
- 9) - Pump the tyre (9) bringing the pressure to four atms.
- 10) - Lower the machine to the ground and place the parking foot definitively (regulating at the best height).

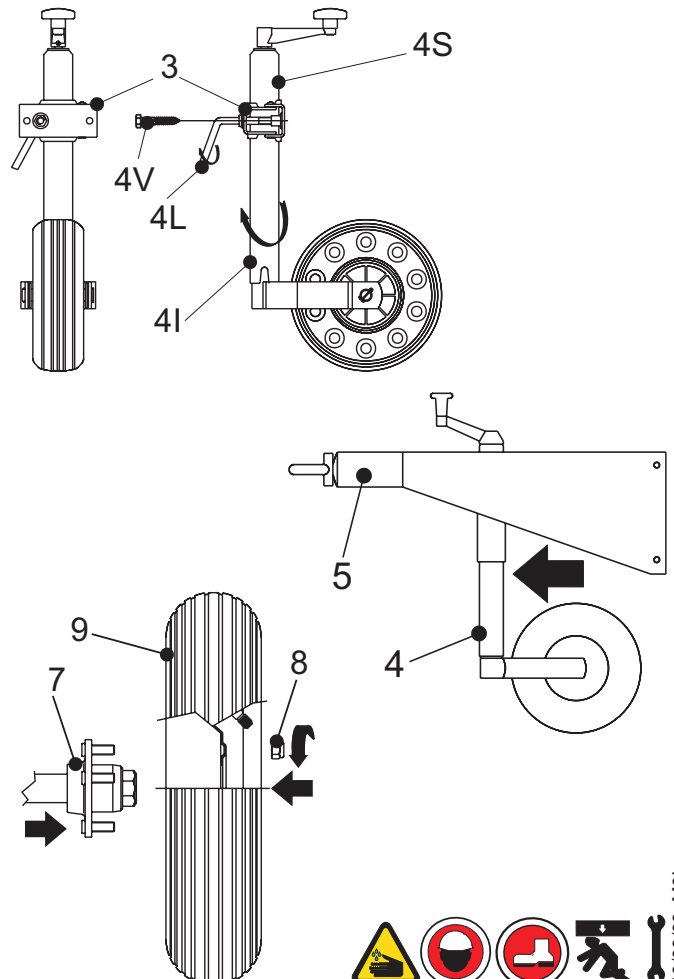

⚠ ATTENTION

Do not substitute the original tires with other types.





BATTERY WITHOUT MAINTENANCE



Connect the cable + (positive) to the pole + (positive) of the battery (after having taken away the protection), by properly tightening the clamp.

Check the state of the battery from the colour of the warning light which is in the upper part.

- Green colour: battery OK
 - Black colour: battery to be recharged
 - White colour: battery to be replaced
- DO NOT OPEN THE BATTERY.**



LUBRICANT

RECOMMENDED OIL

MOSA recommends selecting **AGIP** engine oil. Refer to the label on the motor for the recommended products.

<p>PRODOTTI RACCOMANDATI RECOMMENDED PRODUCTS</p>	
<p>AGIP SUPERDIESEL 15W/40 API CF4-SG</p>	<p>OLIO MOTORE DIESEL DIESEL ENGINE OIL</p> <input type="checkbox"/>
<p>AGIP SUPERMOTOROIL 20W/50 API CC-SF</p>	<p>OLIO MOTORE BENZINA GASOLINE ENGINE OIL</p> <input type="checkbox"/>
<p>AGIP ANTIFREEZE EXTRA INIBITE ETHYLENE GLYCOL (50% + 50% H₂O)</p>	<p>CIRCUITO DI RAFFREDDAMENTO COOLING CIRCUIT (CUNA NC 956-16 ED 97)</p> <input type="checkbox"/>

Please refer to the motor operating manual for the recommended viscosity.

REFUELLING AND CONTROL:

Carry out refuelling and controls with motor at level position.

1. Remove the oil-fill tap (24)
2. Pour oil and replace the tap
3. Check the oil level using the dipstick (23); the oil level must be comprised between the minimum and maximum indicators.



AIR FILTER

Check that the dry air filter is correctly installed and that there are no leaks around the filter which could lead to infiltrations of non-filtered air to the inside of the motor.



FUEL



ATTENTION



Do not smoke or use open flames during refuelling operations, in order to avoid explosions or fire hazards.

Fuel fumes are highly toxic; carry out operations outdoors only, or in a well-ventilated environment.



Avoid accidentally spilling fuel. Clean any eventual leaks before starting up motor.

Refill the tank with good quality diesel fuel, such as automobile type diesel fuel, for example.

For further details on the type of diesel fuel to use, see the motor operating manual supplied.

Do not fill the tank completely; leave a space of approx. 10 mm between the fuel level and the wall of the tank to allow for expansion.

In rigid environmental temperature conditions, use special winterized diesel fuels or specific additives in order to avoid the formation of paraffin.



ATTENTION

It is dangerous to fill the motor with too much oil, as its combustion can provoke a sudden increase in rotation speed.



**COOLING LIQUID****ATTENTION**

Do not remove the radiator tap with the motor in operation or still hot, as the liquid coolant may spurt out and cause serious burns. Remove the tap very carefully.

Remove the tap and pour the liquid coolant into the radiator; the quantity and composition of the liquid coolant are indicated in the motor operating manual. Replace the tap, ensuring it is perfectly closed.

After refilling operations, allow the motor to run for a brief time and check the level, as it may have diminished due to air bubbles present in the cooling circuit; restore the level with water.

To replace the liquid coolant, follow the operations described in the motor operating manual.

**GROUNDING CONNECTION**

The grounding connection to an earthed installation **is obligatory** for all models equipped with a differential switch (circuit breaker). In these groups the generator star point is generally connected to the machine's earthing; by employing the TN or TT distribution system, the differential switch guarantees protection against indirect contacts.

In the case of powering complex installations requiring or employing additional electrical protection devices, the coordination between the protection devices must be verified.

For the grounding connection, use the terminal (12); comply to local and/or current regulations in force for electrical installations and safety.





NOTE
 Do not alter the primary conditions of regulation and do not touch the sealed parts.

ATTENTION

1. By start-up of the generator the welding circuit is immediately operative, i.e. under voltage. Make sure that there are no unwished electrical contacts between the components of the outside welding circuit (electrode, electrode holder gun, workpiece, etc...).

2. Check that at the start-up the a.c. auxiliary generation sockets do not feed any load. Open the electric protection interrupter of the generator or disconnect the plugs of the loads from the sockets.

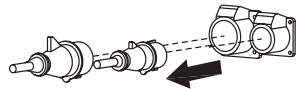
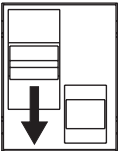

3. START-UP

Remember that when the machines with auto-idle have the signal set to "auto-idle" will remain at the minimum no. of revs (tickover) as long as no current is drawn.

Drawing power will automatically raise the number of engine revs to the nominal value and likewise the tension in the alternator.

Instead, by setting the auto-idle signal to "max", the engine revs will immediately rise to the nominal value and likewise the tension in the alternator.

For the machines with manual accelerator, it is necessary to accelerate the motor manually in order to reach the nominal tension.

Starting is actuated using the key which is an integral part of the EP7 post on the front panel.

- A) - Turn the key in a clockwise direction until all the LED lights are illuminated.
- B) - Wait until the "OIL PRESSURE" and "BATTERY VOLTAGE" LEDs remain illuminated. If the timer lamp is used, the yellow "PREHEAT" LED comes on for the set time of the imposed settings.
- C) - As soon as the green "ENGINE RUNNING" LED starts to flash, actuate the key switch in a clockwise direction (momentarily in the position then with return to rest) until obtaining starting of the engine.

If the motor does not start within 15 seconds, the non starting alert will intervene: the two LEDs "Engine running" and "glow plug" will flash alternately (see motor protection description).

D) - At any time it is possible to stop the engine by turning the key in an anti-clockwise direction (OFF position).

In case of engine anomaly due to low oil pressure, high temperature, broken transmission belt, low fuel level or emergency the EP7 will automatically stop the engine.

- 4. The machines with auto-idle tickover at a minimum of 2400- 2500 rpm. After starting, allow the engine to run for a few minutes before drawing any charge, see the related table below. The machines with a manual accelerator tickover at around 2000 rpm. Also in this case, respect the warm up period in the table.

Temperature	Time
≤ - 20° C	5 min.
to - 20° C from -10°C	2 min.
to - 10° C from -5°C	1 min.
≥ 5° C	20 sec.

- 5. start-up at low temperatures.

The motor will normally start up without problems down to temperatures of -10° C, -15° C. In case of starting difficulty, it is possible to repeat the starting preheating for a max. time of 10 second, lightly turning the trimmer situated at the back of the EP7 in a clockwise direction (see page M39.13 relating to engine protection "trimmer/ glow plug"). For start-up and use at lower temperatures please see the engine manual or turn to our Technical Assistance Center.

In case of unsuccessful start-up, do not insist for longer than 5 seconds. Wait 10 - 15 seconds before attempting another start-up.

CAUTION
 RUNNING-IN
 During the first 50 hours of operation, do not use more than 60% of the maximum output power of the unit and check the oil level frequently, in any case please stick to the rules given in the engine use manual.

STOP

For shutdown under normal conditions, proceed as follows:

1. Break the welding process in course

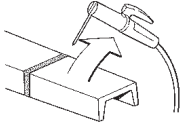

2. Break the production of a.c. auxiliary generation dividing the loads or opening the GFI (D).

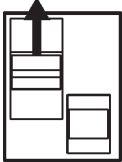

3. Let the engine run with no load for a few minutes.
Set the engine speed to minimum, signal of motor speed to "auto-idle", or accelerator to minimum for manual accelerator.

4. Turn the start key on the EP7 to the OFF position.

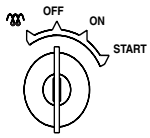
**EMERGENCY SHUTDOWN**

To stop the group in a dangerous situation, press the emergency stop button (L5) (or turn the start key (Q1) to the OFF position). To reset the knob, turn it clockwise.

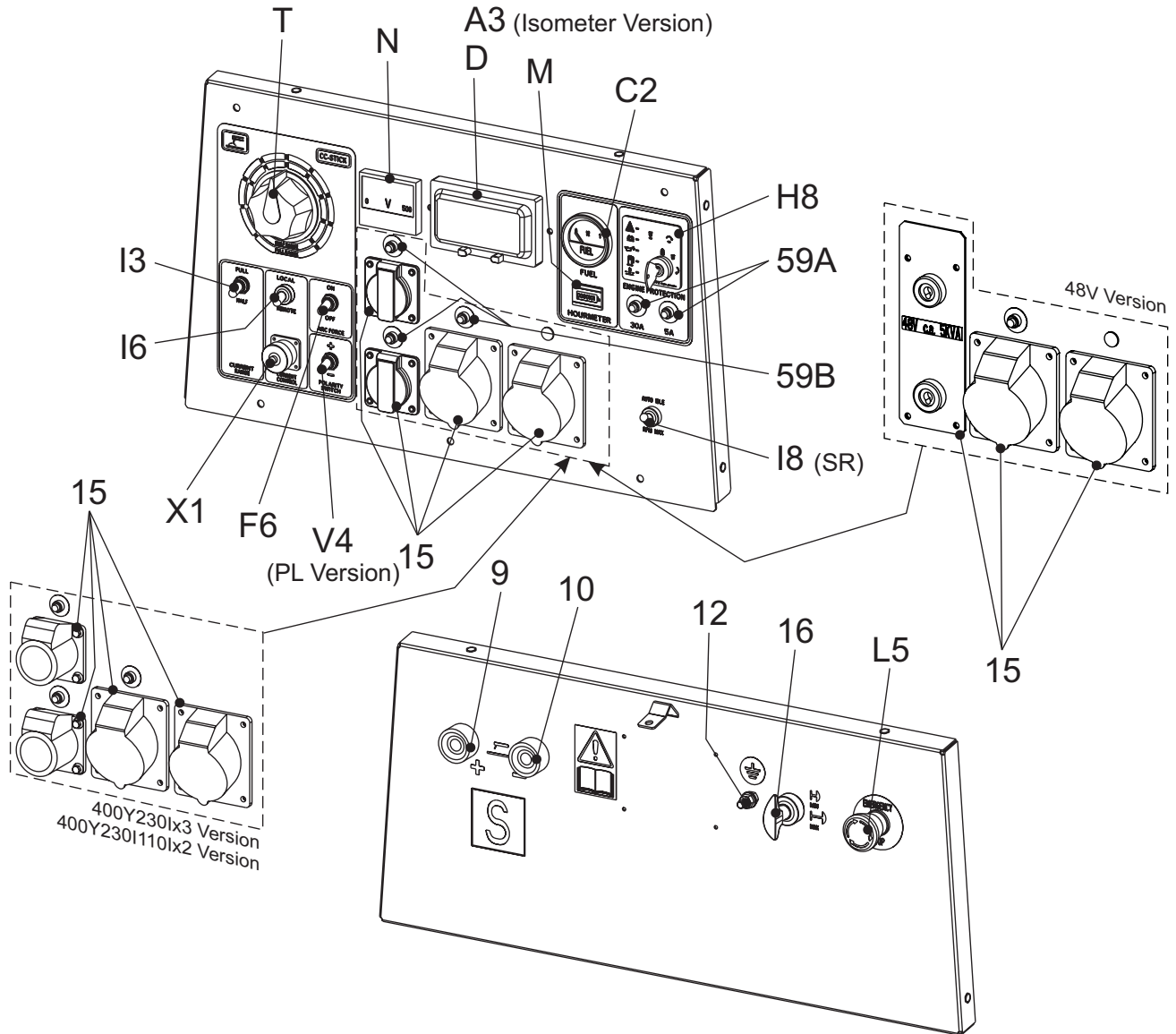

Pos.	Descrizione	Description	Description	Referenzliste
9	Presa di saldatura (+)	Welding socket (+)	Prise de soudage (+)	Schweißbuchse (+)
10	Presa di saldatura (-)	Welding socket (-)	Prise de soudage (-)	Schweißbuchse (-)
12	Presa di messa a terra	Earth terminal	Prise de mise à terre	Erdanschluß
15	Presa di corrente in c.a.	A.C. socket	Prises de courant en c.a.	Steckdose AC
16	Comando acceleratore	Accelerator lever	Commande accélérateur	Beschleuniger (Gashebel/Gaszug)
59A	Protezione termica motore	Engine thermal switch	Protection thermique moteur	Thermoschutz Motor
59B	Protezione termica corrente aux	Aux current thermal switch	Protection thermique courant aux.	Thermoschutz Hilfsstrom
A3	Sorvegliatore d'isolamento	Insulation monitoring	Contrôle d'isolation	Isolationsüberwachung
C2	Indicatore livello combustibile	Fuel level light	Indicateur niveau carburant	Anzeige Kraftstoffpegel
D	Interruttore differenziale (30mA)	G.F.I.	Interrupteur différentiel	FI-Schalter (GFI)
F6	Selettore Arc-Force	Arc-Force selector	Selecteur Arc-Force	Schalter Arc-Force
H8	Unità controllo motore EP7	Engine control unit EP7	Protection moteur EP7	Motorschutz EP7
I3	Commut. riduz. scala saldatura	Welding scale switch	Commutateur échelle soudage	Bereichsschalter Schweißstrom
I6	Selettore Start Local/Remote	Start Local/Remote selector	Selecteur Start Local/Remote	Umschalter Fernstart
I8	Selettore AUTOIDLE	AUTOIDLE switch	Selecteur AUTOIDLE	Schalter AUTOIDLE
L5	Pulsante stop emergenza	Emergency button	Bouton d'urgence	Notschalter
M	Contaore	Hour counter	Compte-heures	Stundenzähler
N	Voltmetro	Voltmeter	Voltmètre	Voltmeter
T	Regolatore corrente di saldatura	Welding current regulator	Régulateur courant soudage	Schweißstromregler
V4	Comando invertitore polarità	Polarity inverter control	Commande inverseur polarité	Polwendeschalter
X1	Presa per comando a distanza	Remote control socket	Prise pour télécommande	Steckdose Fernbedienung



This symbol (Norm EN 60974-1 security standards for arc welders) signifies that the welder can be used in areas with increased risk of electrical shock.



ATTENTION

The sockets, after the machine is started (see pages M21-26), also with no cables, are anyway under voltage.



ATTENTION

The areas, access of which is forbidden to unqualified personnel, are:

- the control switchboard (front) - the exhaust of the endo-thermic engine - the welding process.

Check at the beginning of any work the electric parameters and/or the control placed on the front.

Make sure that the ground connection (12) is efficient (keep to installation local rules and/or to national laws), in order to integrate or ensure the working of various electric protection devices referring to the several distribution system TT/TN/IT, operation unnecessary for machine with isometer.

Fully insert the welding cable plugs into the corresponding sockets turning them clockwise to lock them in position.

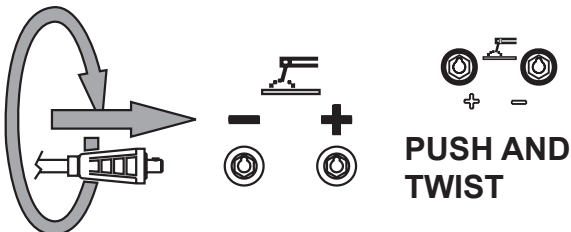

Make sure that the ground clamp, whose cable must be connected to the + or - terminal, depending on the type of electrode, makes a good connection and is near to the welding position.

Pay attention to the two polarities of the welding circuit, which must not come in electric contact between themselves.



REMOTE CONTROL TC...

See page M 38

WELDING CURRENT REGULATOR



Position welding current adjusting knob (T) in correspondance of the chosen current value, so as to obtain the necessary amperage, taking into account the diameter and the type of the electrode.

For technical data see page M1.6

SWITCH REDUCTION SCALE

MAX A
200 A



For small electrodes (up to Ø 3.25-130A and 4-200A) it is recommended to use the reduction scale switch (I3) allowing a more accurate regulation of the welding current (lever position at 200A).

When using electrodes of a diameter greater than 3.25 and/or 4 set the welding scale knob to max. position.

SWITCH POLARITY INVERTER



Polarity switch

It permits to have at the electrode holder the positive or negative polarity of the welding diode bridge.

It is used above all in the first run with cellulosic electrodes to lower the bath temperature and so doing ease up the welding on pipes of small thickness

SWITCH "ARC FORCE" (BASE CURRENT)

Positioning the switch on „ON“, is obtained a low voltage welding current which keeps, always, the lit arc necessary for some types of cellulosic/basic electrodes or when a high penetration is wanted.



ON

For electrodes of rutile type, position the switch on "OFF".

OFF

For technical data see page M52

At the end of every welding process and/or work, proceed with all the use operations **in inverted sense**.

To stop the machine see pages M 22.



ATTENTION

To reduce the risk of electromagnetic interferences, use the minimum length of welding cables and keep them near and down (ex. on the floor).

The welding operations must take place far from any sensitive electronic device. Make sure that the unit is earthed (see M20 and/or M25). In case the interference should last, adapt further disposition, such as: move the unit, use screened cables, line filters, screen the entire work area.

In case the above mentioned operations are non sufficient, please contact our Technical Assistance Service.



CAUTION

With a welding cable length up to 20 m is suggested a section of 35 mm²; with longer cables a bigger section is required.





WARNING

It is strictly forbidden to connect the group to the public mains and/or to any other source of electric power.

GENERATION IN AC (ALTERNATING CURRENT)

Make certain of the efficiency of the ground connection (12) - See page M20 -

Position the G.F.I. switch to ON.

☞ Voltage is now immediately available to the AC sockets.

Verify that the voltmeter displays the nominal voltage value + 10%.

Connect the electric devices to be powered to the AC sockets, using suitable plugs and cables in good condition.

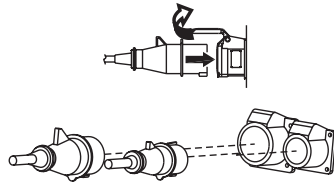

☞ Verify that the electrical characteristics (voltage/frequency/power) of the device being powered are compatible with those of the generator.

Low frequency and/or voltage can irreparably damage some electrical devices.

Verify that the ground lead of the electrical appliance/tool to be powered is correctly connected to the terminal of the plug.

☞ For double insulation devices with the symbol , the plug's ground terminal does not need to be grounded.

THERMAL PROTECTION

The monophase outputs are protected against overloads by the thermal protection (59B).

When the rated current is exceeded, the protection intervenes to cut off the voltage to the AC socket.

. Note: the intervention of the thermal protection is not instantaneous, but reacts according

to an overcurrent/time characteristic, whereby the greater the overcurrent the quicker the intervention.

In case of intervention by the protection device, verify that the total power for the loads connected does not exceed the declared rating and decrease if necessary. Disconnect the loads and wait a few minutes to allow the thermal protection to cool down.



CIRCUIT BREAKER



Before resetting by pressing the central button and then connect the load again.

If the protection should intervene again, replace it with another one with matching intervention current specifications and/or contact the Service Department.

. Note: do not forcibly hold the central button of the thermal protection device to prevent its intervention, as this could irreparably **damage** the unit's alternator.

☞ Note: the three phase output does not require any protection against overcurrents, since it uses a self-protecting asynchronous type alternator.

GROUND FAULT INTERRUPTOR SWITCH

The high-sensitivity ground fault interruptor switch [G.F.I.] (30mA) (D), guarantees protection against indirect contacts due to faulty ground currents .

When the G.F.I. switch picks up a faulty ground current that is higher than 30mA, it intervenes by immediately cutting off voltage to the AC sockets.

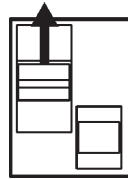

In case of intervention by this protection device, reset the G.F.I. switch by moving the lever to the ON position. In case of another intervention, verify that there are no faults in the tools connected, or replace the G.F.I. switch with another one of matching specifications and/or contact the Service Department.

☞ Notes: Verify the operation of the G.F.I. switch at least once a month by pressing the TEST button. The generator must be running and the G.F.I. lever in the ON position.

SIMULTANEOUS USE

The welder's alternator permits the simultaneous use of auxiliary power and welding current. The auxiliary power available to the AC plugs (15) diminishes as the welding current drawn increases. The table on page M52 TECHNICAL SPECIFICATIONS shows the amount of auxiliary power available as the welding current varies.

COMBINED USE

The output available from the various auxiliary power sockets is limited, not only by the declared output of the unit but also by the capacity of each individual socket.

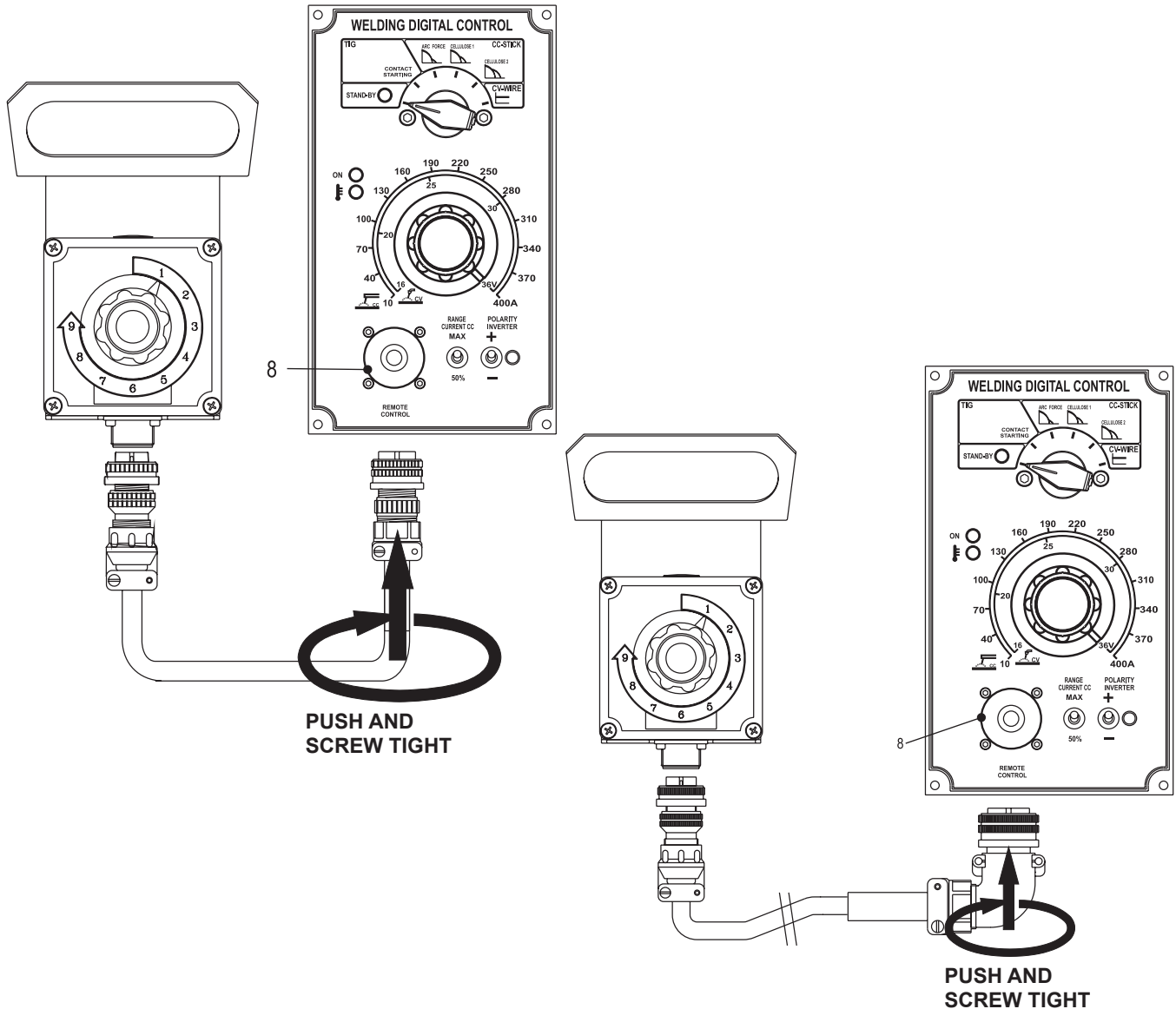

The remote control RC, which regulates the welding current in the CC (STICK welding) mode and the welding voltage in the CV (MIG/MAG welding), is connected to the front panel by means of a multipole connector.

When the remote control is connected to the remote control connector (8), it is functional and automatically excludes the front panel regulation. The remote control can also be connected to the connector on the wire feeder front panel but in this case it is necessary to switch the wire feeder commutator so it can operate.

Adjust the welding current control knob to the correct current for the diameter and type of electrode being welded.



ATTENTION

When the RC is not used, it is necessary to disconnect the multipole connector

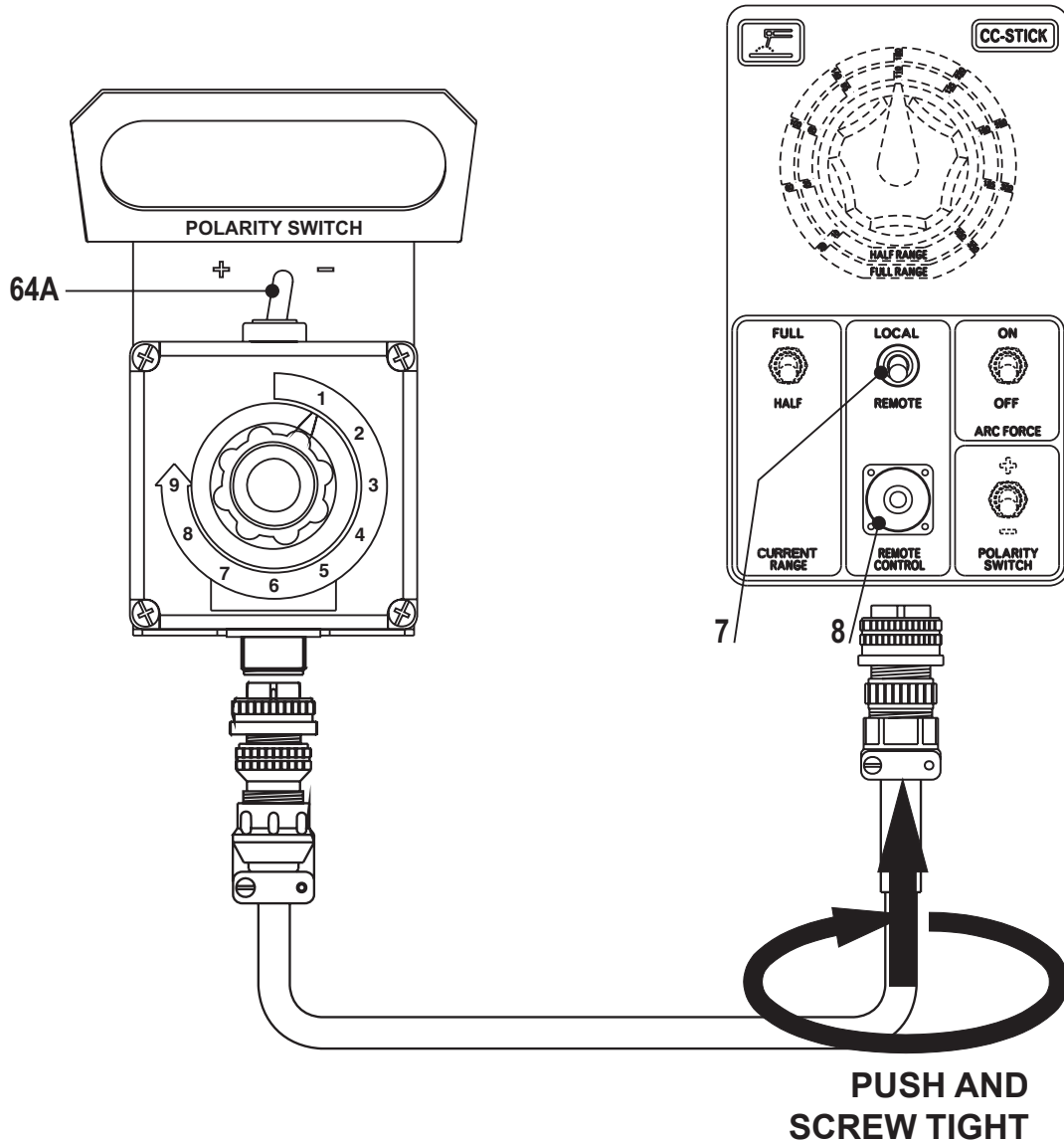

The remote control device for regulating the welding current is connected to the front panel by means of a multipole connector.

To regulate the current from the RC, move the switch (7), located above the multipole connector (8), to "ON" position.

The remote control of the polarity inverter (64A) permits to inverse the polarity directly from the control itself.

Position the (T) welding current adjusting knob at the necessary current value in order to obtain the necessary amps, according to the diameter and type of electrode.



MAKE SURE

When the RCPL is not used, make sure that the switch is in the "LOCAL" position.



NOTE

Don not intervene on the setting of the protection switch. Before using the machine check the ON warning lamp lighting.

USE AS TROUBLE INDICATOR:

Placed on the front panel, the insulation monitor (A3) is a relay which controls continuously the insulation of the generation a.c. circuits towards the ground.

The device generates internally a continuous 12V voltage which is applied between the circuit under control and the ground.

USE AS TROUBLE INDICATOR AND INTERVENTION:

The insulation monitor controls a device (release coil, contactor, etc.) which opens the whole circuit, lifting voltage in the whole part of the machine a.c. generation.

USE OF RI – R22M MODEL:

- To vary the regulation call our Technical Assistance Department
- The LED ON shows that the device is fed.
- Check that it works correctly pressing the TEST push button
- The LED TRIP will simulate on intervention or anyway will show the real intervention in case the insulation fails.
- Reset the circuit pressing the RESET push button after having checked the plant and removed the problem cause.

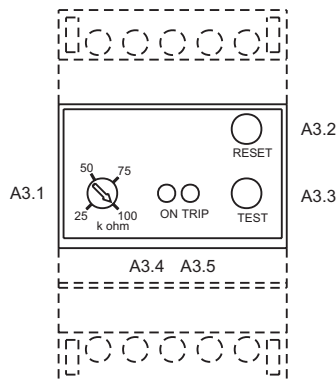

LEGEND:

- A3.1 - Adjustment potentiometer insulation resistance
- A3.2 - Manual reset push button
- A3.3 - Test push button
- A3.4 - Auxiliary feeding presence LED
- A3.5 - TRIP LED

USE OF SRI/D3 MODEL

- To vary the regulation call our Technical Assistance Department
- The warning light ON shows that the device is fed.-
- Pressing a long time the Test push-button, the Fault led lights and the Alarm led twinkles;
- Leaving it, the Alarm led goes off while the Fault led remains lit. The pressure on the Reset key brings the device back to initial conditions.
- If the insulation resistance goes down below the fixed alarm value, the Alarm led twinkles, at the same time the Alarm contact switches; if the insulation resistance goes down furtherly and becomes inferior to the fixed value for the Fault, the Fault led lights and at the same time both exchange contacts switch putting the Fault in activity and the Alarm at rest.
- After having checked the device and removed the cause of the problem, re-establish the circuit pressing the push-button RESET.

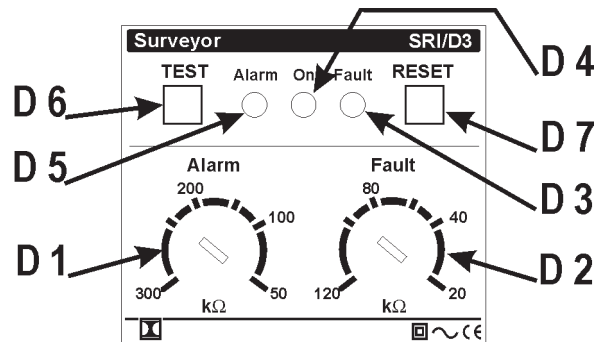

LEGEND:

- D1 Regulation of Alarm threshold
- D2 Regulation of Fault threshold
- D3 Led, fault indication
- D4 Led feeding indication
- D5 Led Alarm indication
- D6 Test push-button
- D7 Reset push-button

Description

The EP7 includes the basic safeguards to protect an DIESEL engine. The EP7 features 7 LEDs, 3 Static Outputs and a 30A Key Switch. The EP7 monitors an Oil Pressure-switch, Temperature-switch, Fuel Level-switch, Charger Alternator Voltage, and an Emergency-switch.

Specification

DC Supply, Battery Plant	8V up to 36 Vdc
Static Outputs (short circuit proof)	200 mAdc
Key Switch Rating	30 A (30 secs)/80 A (5 secs)
Dimensions-DIN 96 Size	72X72X55 (ex switch /key)
Weight	300 gr
Operating Temperature	-30° C /+70° C
Operating Humidity	96% (non-condensing)

[PREHEAT] yellow LED

This indicator illuminates during the Pre-Glow cycle (10 secs to 60 secs).

[EMERGENCY] red LED

This LED illuminates continuously when a shut down has been caused by the Emergency switch.

[ALTERNATOR FAILURE] red LED

This LED illuminates before engine starting or if a Belt Break shut down occurs (than 20 secs).

[OIL PRESSURE] red LED

This LED illuminates before engine starting or if an Oil Pressure shut down occurs.

[FUEL LEVEL] red LED

This LED blinks when a low fuel condition occurs. This LED illuminates continuously to indicate a shut down, if the switch has been closed for more than 5 minutes.

[TEMPERATURE] red LED

This LED illuminates when an High Temperature shut down occurs.

[ENGINE RUNNING] green LED

This LED blinks for 15 seconds, indicating that the EP7 is ready to start the engine (you have to turn the key to start). If the engine does not run within 15 seconds, the "Starting Failure" alarm will take place. This LED illuminates continuously if the engine runs.

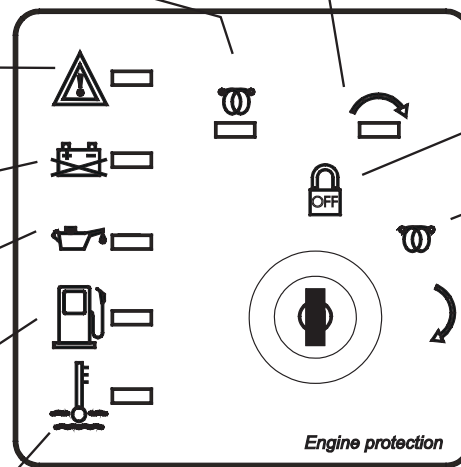

[KEY-SWITCH] OFF position
[KEY-SWITCH] Pre-Heat position
[KEY-SWITCH] START position

[STARTING FAILURE ALARM] indication
These 2 LEDs blink alternately (slowly) to indicate a starting failure alarm.

[OPTIONAL ALARM] indication
These 2 LEDs blink alternately (quickly) to indicate the intervention of the alarm.

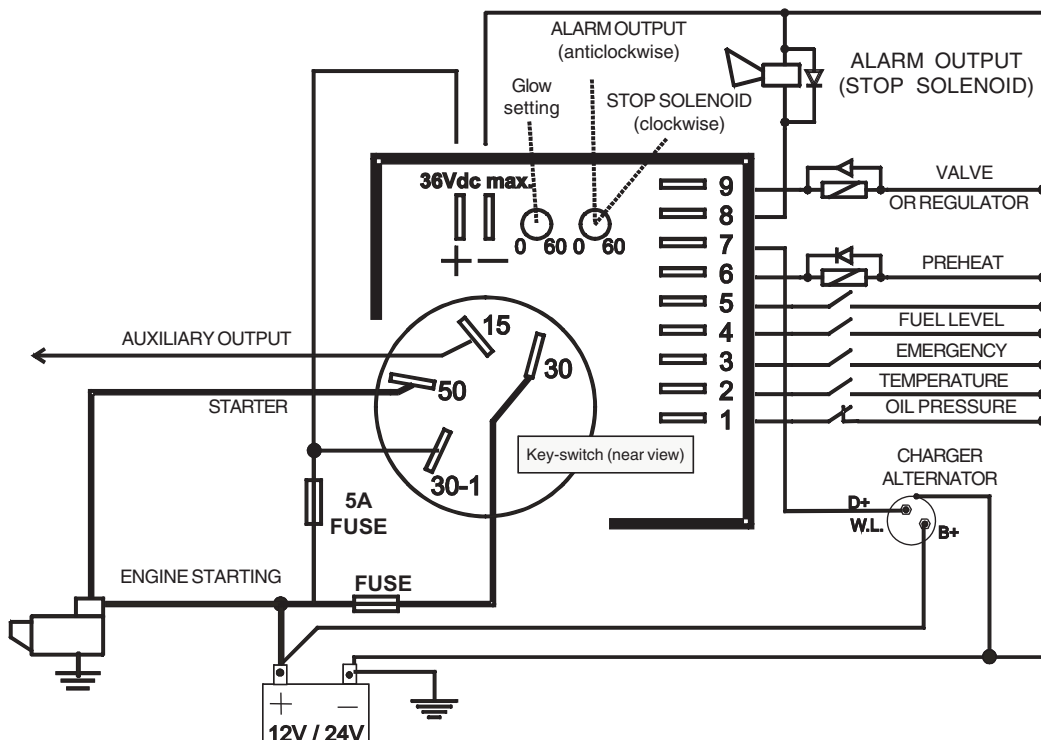

Problems	Possible cause	Solution
WELDING		
P1 No welding current but auxiliary output is OK	1) Position of remote control switch 2) Potentiometer defect in welding current control 3) Welding current signal interrupter 4) Defect card 5) Defect in diode bridge	1) Check that it is in OFF position if there is no remote control, on "0" with remote control inserted. 2) Check the continuity of the welding potentiometer and relative connections. 3) Check that cables from current sensor to card are in perfect state. 4) Replace card. 5) Check the diode or the controlled diodes.
P2 There is welding but non penetration	1) Starter (STARTER for SCR) faulty 2) Welding bridge faulty	1) Replace starter 2) Replace the welding bridge
P3 Defect in welding, high and discontinued sparks	1) Current sensor faulty 2) Defect in diode bridge 3) Defect in card	1) Replace the current sensor 2) Check the diodes and controlled diodes. 3) Replace the card.
P4 No welding output and no auxiliary power output	1) Short circuit in wiring 2) Defective condenser 3) Defective stator 4) Short circuited diode bridge	1) Check the wiring inside the welder for a short circuit between cables or to ground. 2) If the wiring is OK, short circuit the condenser to be sure that it is discharged, disconnect all wires from condenser and, using an ohmmeter, check that the condenser is not short circuited. 3) If the condenser box is OK, disconnect all leads from the stator except for those going to the condenser box and check the output from the alternator. If there is no output from the welding winding and the auxiliary winding, replace the stator. 4) If there is output from all windings reconnect the diode bridge and check if there is welding current. If not the diode bridge is defective. If there is welding current connect the auxiliary power leads one at a time until there is no output; at this point, the short circuit is in that line.
GENERATING		
P1 Voltmeter shows no voltage or low voltage but actual voltage at the sockets is OK.	1) Voltmeter malfunction	1) Replace the voltmeter.
P2 No three-phase voltage present at the socket(s) but voltmeter reading is normal and there is voltage on the other sockets.	1) Differential or isometer switch not inserted 2) Differential or isometer switch malfunction	1) Turn on the switch. 2) Replace the switch.
P3 No single phase voltage one socket but voltmeter reading is normal and there is voltage on the other sockets.	1) Intervention of thermal switch due to excessive current. 2) Thermal switch malfunction.	1) Push in the thermal switch. 2) Replace the thermal switch.
P4 No voltage present.	1) Short circuit present on the generator outputs.	1) Disconnect all outputs on the generator except for those on the condensers and re-start machine; check for voltage on condensers.

<i>Problems</i>	<i>Possible cause</i>	<i>Solution</i>
ENGINE		
P1 The engine does not start or stops immediately after startup.	1) Low battery voltage, battery dead or defective 2) Presence of air in the fuel supply circuit 3) Presence of water in the pre-filter (where fitted). 4) Engine protection termic/fuse blown	1) Check the level of the electrolyte. Fill or replace the battery 2) Carry out de-aeration on the fuel system. See engine operating manual 3) Eliminate the water, see motor manual 4) Replace. In case the problem persists, check the electrical circuit and eliminate the problem. Call an authorised service centre.
P2 Engine stops due to intervention of ES protection.	1) Engine temperature too high or insufficient oil pressure. 2) High temperature sensor or oil pressure defective. 3) ES protection defective. 4) Stop solenoid defective.	1) Check oil level. 2) Replace the malfunctioning sensor. 3) Replace the protection. 4) Replace
P3 The battery is not charged.	1) Battery charger alternator defective. 2) Battery charger warning light defective.	1) Replace 2) Replace
P4 For other problems, refer to the attached engine manual		



WARNING



**MOVING
PARTS
can injure**

- Have **qualified** personnel do maintenance and troubleshooting work.
- Stop the engine before doing any work inside the machine. If for any reason the machine must be operated while working inside, **pay attention** moving parts, hot parts (exhaust manifold and muffler, etc.) electrical parts which may be unprotected when the machine is open.
 - Remove guards only when necessary to perform maintenance, and replace them when the maintenance requiring their removal is complete.
 - Use suitable tools and clothes.
 - Do not modify the components if not authorized.
- See pag. M1.1 -



**HOT surface
can
hurt you**

NOTE

By maintenance at care of the utilizer we intend all the operatios concerning the verification of mechanical parts, electrical parts and of the fluids subject to use or consumption during the normal operation of the machine.

For what concerns the fluids we must consider as maintenance even the periodical change and or the refills eventually necessary.

Maintenance operations also include machine cleaning operations when carried out on a periodic basis outside of the normal work cycle.

The repairs **cannot be considered** among the maintenance activities, i.e. the replacement of parts subject to occasional damages and the replacement of electric and mechanic components consumed in normal use, by the Assistance Authorized Center as well as by MOSA.

The replacement of tires (for machines equipped with trolleys) must be considered as repair since it is not delivered as standard equipment any lifting system.

The periodic maintenance should be performed according to the schedule shown in the engine manual. An optional hour counter (M) is available to simplify the determination of the working hours.



IMPORTANT



In the maintenance operations avoid that polluting substances, liquids, exhausted oils, etc. bring damage to people or things or can cause negative effects to surroundings, health or safety respecting completely the laws and/or dispositions in force in the place.

ENGINE and ALTERNATOR

PLEASE REFER TO THE SPECIFIC MANUALS PROVIDED.

Every engine and alternator manufacturer has

maintenance intervals and specific checks for each model: it is necessary to consult the specific engine or alternator USER AND MAINTENANCE manual.

VENTILATION

Make certain there are no obstructions (rags, leaves or other) in the air inlet and outlet openings on the machine, alternator and motor.

ELECTRICAL PANELS

Check condition of cables and connections daily. Clean periodically using a vacuum cleaner, **DO NOT USE COMPRESSED AIR.**

DECALS AND LABELS

*All warning and decals should be checked once a year and **replaced** if missing or unreadable.*

STRENUOUS OPERATING CONDITIONS

Under extreme operating conditions (frequent stops and starts, dusty environment, cold weather, extended periods of no load operation, fuel with over 0.5% sulphur content) do maintenance more frequently.

BATTERY WITHOUT MAINTENANCE DO NOT OPEN THE BATTERY

The battery is charged automatically from the battery charger circuit supplied with the engine.

Check the state of the battery from the colour of the warning light which is in the upper part.

- Green colour: battery OK
- Black colour: battery to be recharged
- White colour: battery to be replaced



NOTE

THE ENGINE PROTECTION NOT WORK WHEN THE OIL IS OF LOW QUALITY BECAUSE NOT CHARGED REGULARLY AT INTERVALS AS PRESCRIBED IN THE OWNER'S ENGINE MANUAL.

In case the machine should not be used for more than 30 days, make sure that the room in which it is stored presents a suitable shelter from heat sources, weather changes or anything which can cause rust, corrosion or damages to the machine.

 Have **qualified** personnel prepare the machine for storage.

GASOLINE ENGINE

Start the engine: It will run until it stops due to the lack of fuel.

Drain the oil from the engine sump and fill it with new oil (see page M25).

Pour about 10 cc of oil into the spark plug hole and screw the spark plug, after having rotated the crankshaft several times.

Rotate the crankshaft slowly until you feel a certain compression, then leave it.

In case the battery, for the electric start, is assembled, disconnect it.

Clean the covers and all the other parts of the machine carefully.

Protect the machine with a plastic hood and store it in a dry place.

DIESEL ENGINE

For short periods of time it is advisable, about every 10 days, to make the machine work with load for 15-30 minutes, for a correct distribution of the lubricant, to recharge the battery and to prevent any possible bloking of the injection system.

For long periods of inactivity, turn to the after sales service of the engine manufacturer.

Clean the covers and all the other parts of the machine carefully.

Protect the machine with a plastic hood and store it in a dry place.

In case of necessity for first aid and of fire prevention, see page. M2.5.



IMPORTANT



In the storage operations avoid that polluting substances, liquids, exhausted oils, etc. bring damage to people or things or can cause negative effects to surroundings, health or safety respecting completely the laws and/or dispositions in force in the place.



☞ Have **qualified** personnel disassemble the machine and dispose of the parts, including the oil, fuel, etc., in a correct manner when it is to be taken out of service.

As cust off we intend all operations to be made, at utilizer's care, at the end of the use of the machine. This comprises the dismantling of the machine, the subdivision of the several components for a further reutilization or for getting rid of them, the eventual packing and transportation of the eliminated parts up to their delivery to the store, or to the bureau encharged to the cust off or to the storage office, etc.

The several operations concerning the cust off, involve the manipulation of fluids potentially dangerous such as: lubricating oil and battery electrolyte.

The dismantling of metallic parts liable to cause injuries or wounds, must be made wearing heavy gloves and using suitable tools.

The getting rid of the various components of the machine must be made accordingly to rules in force of law a/o local rules.

**Particular attention must be paid when getting rid of:
lubricating oils, battery electrolyte, and inflammable liquids such as fuel, cooling liquid.**

The machine user is responsible for the observance of the norms concerning the environment conditions with regard to the elimination of the machine being cust off and of all its components.

In case the machine should be cust off without any previous disassembly it is however compulsory to remove:

- tank fuel
- engine lubricating oil
- cooling liquid from the engine
- battery

NOTE: MOSA is involved with custing off the machine **only** for the second hand ones, when not reparable.

This, of course, after authorization.

In case of necessity for first aid and fire prevention, see page M2.5.



IMPORTANT



In the cust-off operations avoid that polluting substances, liquids, exhausted oils, etc. bring damage to people or things or can cause negative effects to surroundings, health or safety respecting completely the laws and/or dispositions in force in the place.

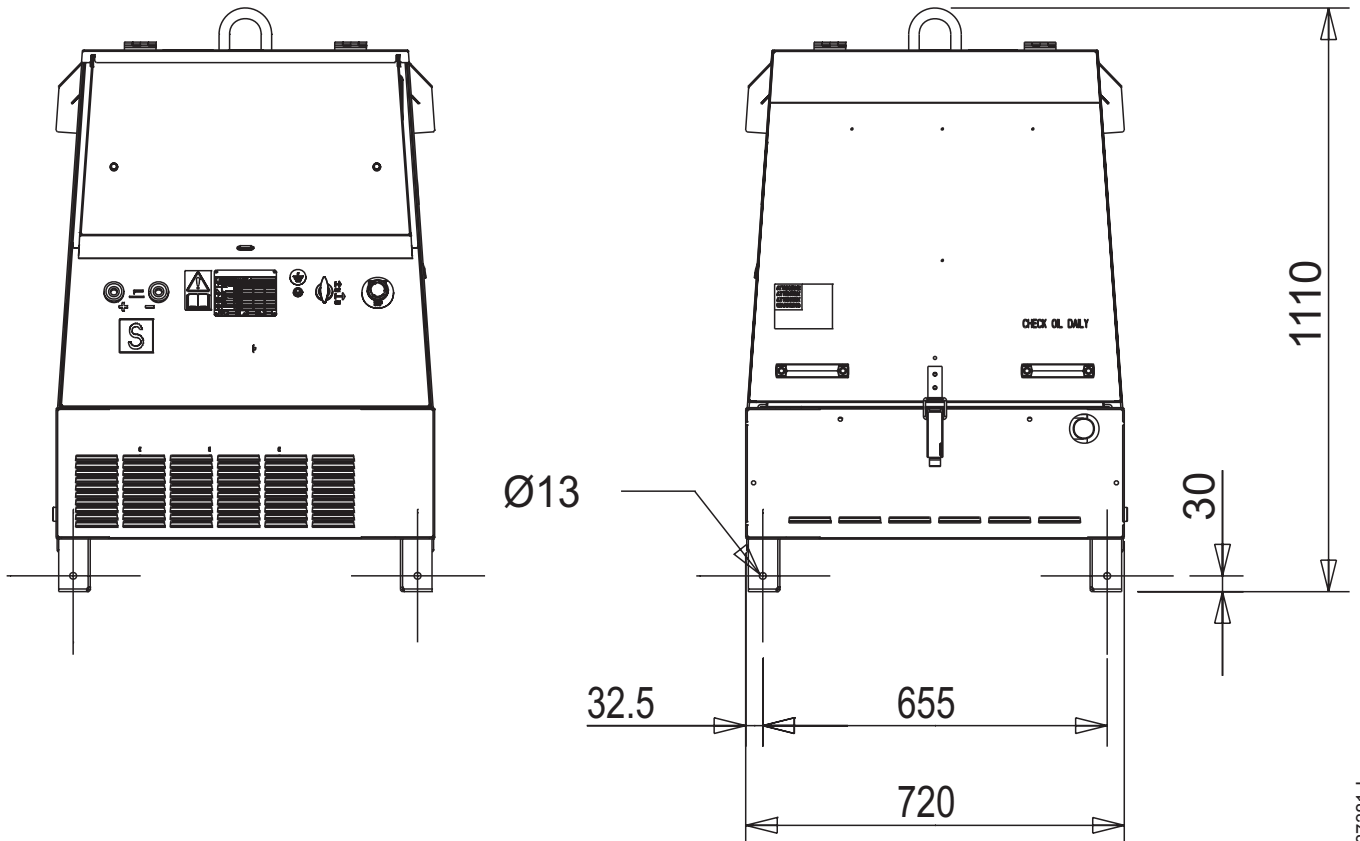
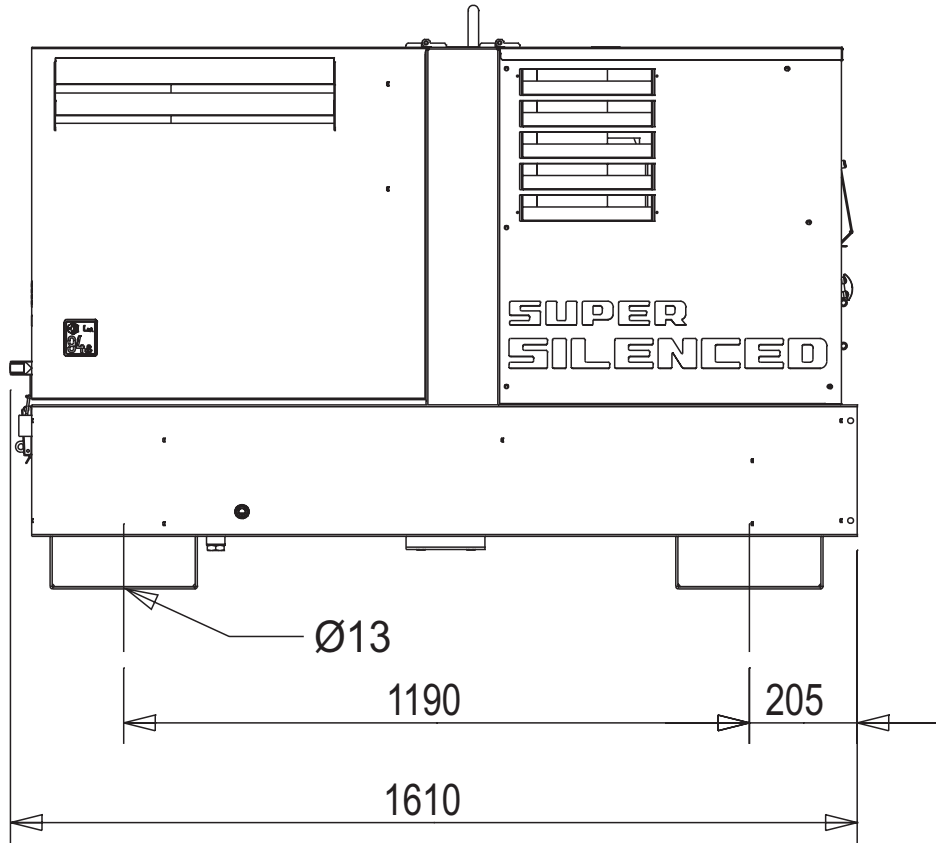

A	: Alternator	A3	: Insulation monitoring	A6	: Commutator/switch
B	: Wire connection unit	B3	: E.A.S. connector	B6	: Key switch, on/off
C	: Capacitor	C3	: E.A.S. PCB	C6	: QEA control unit
D	: G.F.I.	D3	: Booster socket	D6	: Connector, PAC
E	: Welding PCB transformer	E3	: Open circuit voltage switch	E6	: Frequency rpm regulator
F	: Fuse	F3	: Stop push-button	F6	: Arc-Force selector
G	: 400V 3-phase socket	G3	: Ignition coil	G6	: Device starting motor
H	: 230V 1phase socket	H3	: Spark plug	H6	: Fuel electro pump 12V c.c.
I	: 110V 1-phase socket	I3	: Range switch	I6	: Start Local/Remote selector
L	: Socket warning light	L3	: Oil shut-down button	L6	: Choke button
M	: Hour-counter	M3	: Battery charge diode	M6	: Switch CC/CV
N	: Voltmeter	N3	: Relay	N6	: Connector – wire feeder
P	: Welding arc regulator	O3	: Resistor	O6	: 420V/110V 3-phase transformer
Q	: 230V 3-phase socket	P3	: Sparkler reactor	P6	: Switch IDLE/RUN
R	: Welding control PCB	Q3	: Output power unit	Q6	: Hz/V/A analogic instrument
S	: Welding current ammeter	R3	: Electric siren	R6	: EMC filter
T	: Welding current regulator	S3	: E.P.4 engine protection	S6	: Wire feeder supply switch
U	: Current transformer	T3	: Engine control PCB	T6	: Wire feeder socket
V	: Welding voltage voltmeter	U3	: R.P.M. electronic regulator	U6	: DSP chopper PCB
Z	: Welding sockets	V3	: PTO HI control PCB	V6	: Power chopper supply PCB
X	: Shunt	Z3	: PTO HI 20 l/min push-button	Z6	: Switch and leds PCB
W	: D.C. inductor	W3	: PTO HI 30 l/min push-button	W6	: Hall sensor
Y	: Welding diode bridge	X3	: PTO HI reset push-button	X6	: Water heater indicator
		Y3	: PTO HI 20 l/min indicator	Y6	: Battery charge indicator
A1	: Arc striking resistor	A4	: PTO HI 30 l/min indicator	A7	: Transfer pump selector AUT-0-MAN
B1	: Arc striking circuit	B4	: PTO HI reset indicator	B7	: Fuel transfer pump
C1	: 110V D.C./48V D.C. diode bridge	C4	: PTO HI 20 l/min solenoid valve	C7	: "GECO" generating set test
D1	: E.P.1 engine protection	D4	: PTO HI 30 l/min solenoid valve	D7	: Flooting with level switches
E1	: Engine stop solenoid	E4	: Hydraulic oil pressure switch	E7	: Voltmeter regulator
F1	: Acceleration solenoid	F4	: Hydraulic oil level gauge	F7	: WELD/AUX switch
G1	: Fuel level transmitter	G4	: Preheating glow plugs	G7	: Reactor, 3-phase
H1	: Oil or water thermostat	H4	: Preheating gearbox	H7	: Switch disconnect
I1	: 48V D.C. socket	I4	: Preheating indicator	I7	: Solenoid stop timer
L1	: Oil pressure switch	L4	: R.C. filter	L7	: "VODIA" connector
M1	: Fuel warning light	M4	: Heater with thermostat	M7	: "F" EDC4 connector
N1	: Battery charge warning light	N4	: Choke solenoid	N7	: OFF-ON-DIAGN. selector
O1	: Oil pressure warning light	O4	: Step relay	O7	: DIAGNOSTIC push-button
P1	: Fuse	P4	: Circuit breaker	P7	: DIAGNOSTIC indicator
Q1	: Starter key	Q4	: Battery charge sockets	Q7	: Welding selector mode
R1	: Starter motor	R4	: Sensor, cooling liquid temperature	R7	: VRD load
S1	: Battery	S4	: Sensor, air filter clogging	S7	: 230V 1-phase plug
T1	: Battery charge alternator	T4	: Warning light, air filter clogging	T7	: V/Hz analogic instrument
U1	: Battery charge voltage regulator	U4	: Polarity inverter remote control	U7	: Engine protection EP6
V1	: Solenoid valve control PCBT	V4	: Polarity inverter switch	V7	: G.F.I. relay supply switch
Z1	: Solenoid valve	Z4	: Transformer 230/48V	Z7	: Radio remote control receiver
W1	: Remote control switch	W4	: Diode bridge, polarity change	W7	: Radio remote control transmitter
X1	: Remote control and/or wire feeder socket	X4	: Base current diode bridge	X7	: Isometer test push-button
Y1	: Remote control plug	Y4	: PCB control unit, polarity inverter	Y7	: Remote start socket
A2	: Remote control welding regulator	A5	: Base current switch	A8	: Transfer fuel pump control
B2	: E.P.2 engine protection	B5	: Auxiliary push-button ON/OFF	B8	: Ammeter selector switch
C2	: Fuel level gauge	C5	: Accelerator electronic control	C8	: 400V/230V/115V commutator
D2	: Ammeter	D5	: Actuator	D8	: 50/60 Hz switch
E2	: Frequency meter	E5	: Pick-up	E8	: Cold start advance with temp. switch
F2	: Battery charge transformer	F5	: Warning light, high temperature	F8	: START/STOP switch
G2	: Battery charge PCB	G5	: Commutator auxiliary power	G8	: Polarity inverter two way switch
H2	: Voltage selector switch	H5	: 24V diode bridge	H8	: Engine protection EP7
I2	: 48V a.c. socket	I5	: Y/s commutator	I8	: AUTOIDLE switch
L2	: Thermal relay	L5	: Emergency stop button	L8	: AUTOIDLE PCB
M2	: Contactor	M5	: Engine protection EP5	M8	: A4E2 ECM engine PCB
N2	: G.F.I. and circuit breaker	N5	: Pre-heat push-button	N8	: Remote emergency stop connector
O2	: 42V EEC socket	O5	: Accelerator solenoid PCB	O8	: V/A digital instruments and led VRD PCB
P2	: G.F.I. resistor	P5	: Oil pressure switch	P8	: Water in fuel
Q2	: T.E.P. engine protection	Q5	: Water temperature switch	Q8	: Battery disconnect switch
R2	: Solenoid control PCBT	R5	: Water heater	R8	: Inverter
S2	: Oil level transmitter	S5	: Engine connector 24 poles	S8	: Overload led
T2	: Engine stop push-button T.C.1	T5	: Electronic GFI relais	T8	: Main IT/TN selector
U2	: Engine start push-button T.C.1	U5	: Release coil, circuit breaker	U8	: NATO socket 12V
V2	: 24V c.a. socket	V5	: Oil pressure indicator	V8	: Diesel pressure switch
Z2	: Thermal magnetic circuit breaker	Z5	: Water temperature indicator	Z8	: Remote control PCB
W2	: S.C.R. protection unit	W5	: Battery voltmeter	W8	: Pressure turbo protection
X2	: Remote control socket	X5	: Contactor, polarity change	X8	:
Y2	: Remote control plug	Y5	: Commutator/switch, series/parallel	Y8	:

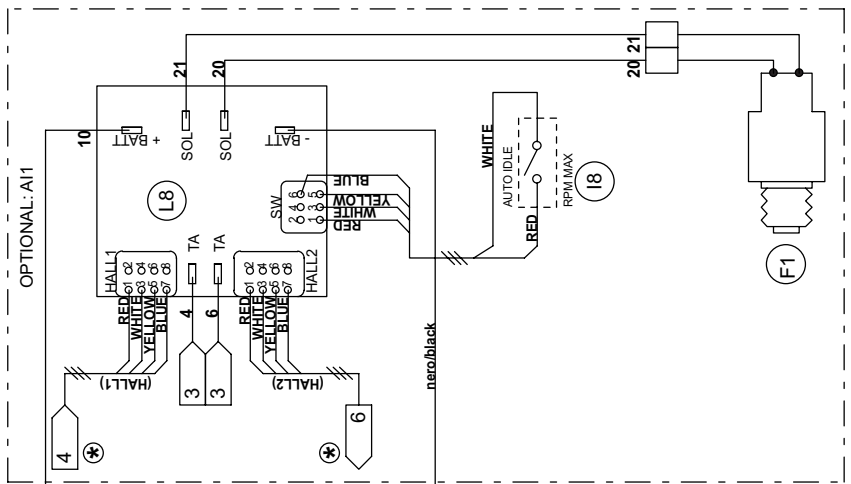
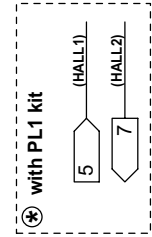
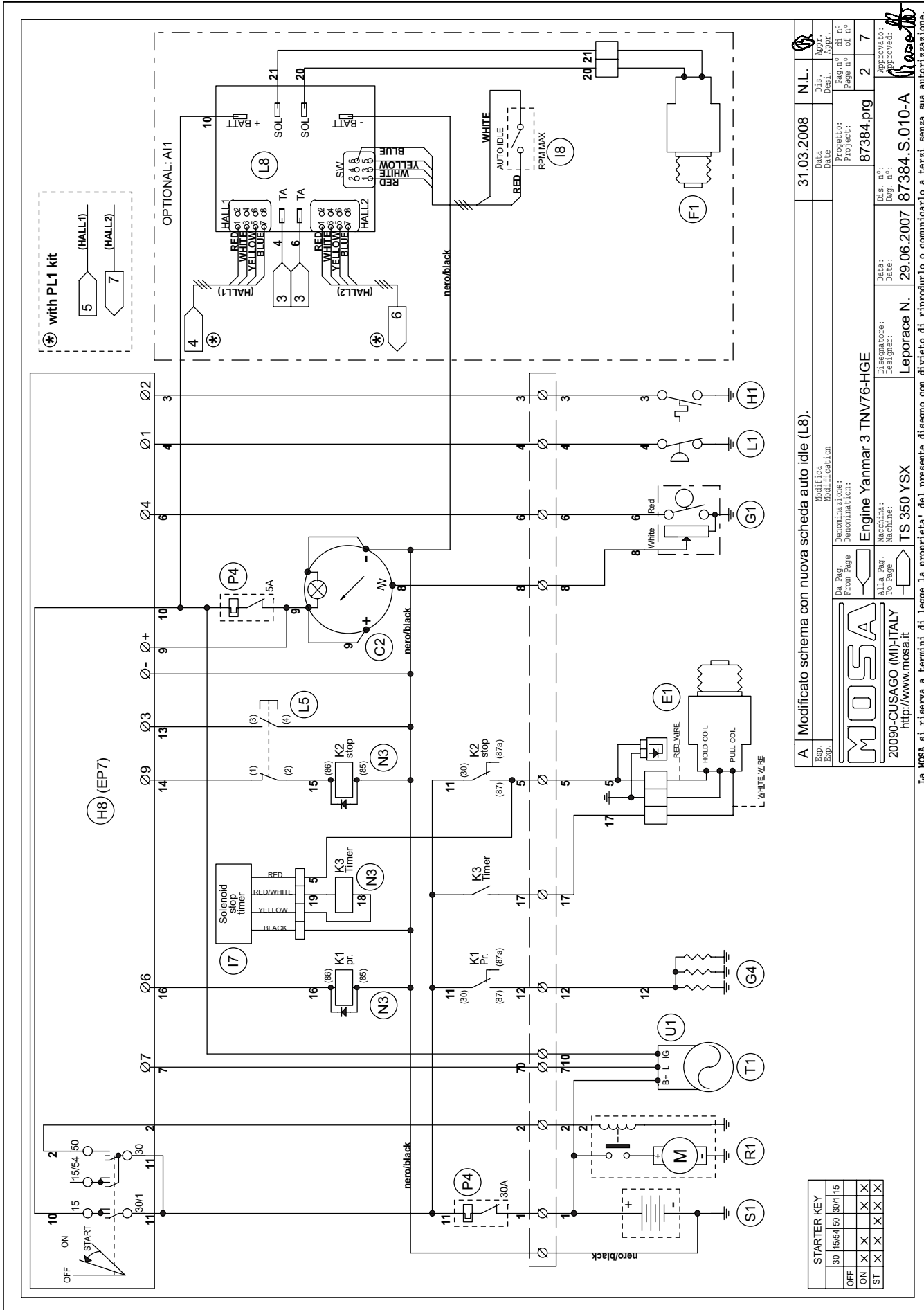

A		Modificato schema con nuova scheda auto idle (L8).		31.03.2008		N.L.	
Esp.:	Modifica	Data	Dis.	Appr.			
Exp.	Modification	Date	Desi.	Appr.			
Da Pag. Denominazione: Engine Yanmar 3 TNV76-HGE		Progetto: 87384.prg		Pag. n° di n°		2	
From Page Denomination: Engine Yanmar 3 TNV76-HGE		Project: 87384.prg		Page n° of n°		7	
MOSA		Disegnatore: Leporace N.		Dis. n°: 87384.S.010-A		Approvato: [Signature]	
20090-CUSAGO (MI)-ITALY		Date: 29.06.2007		Dsg. n°:		Approved:	
http://www.mosa.it		Machine: TS 350 YSX		Dsg. n°:		Approved:	

STARTER KEY

30	15/54	50	30/115
OFF	X	X	X
ON	X	X	X
ST	X	X	X

La MOSA si riserva a termini di legge la proprietà del presente disegno con divieto di riproduzione o comunicato a terzi senza sua autorizzazione.

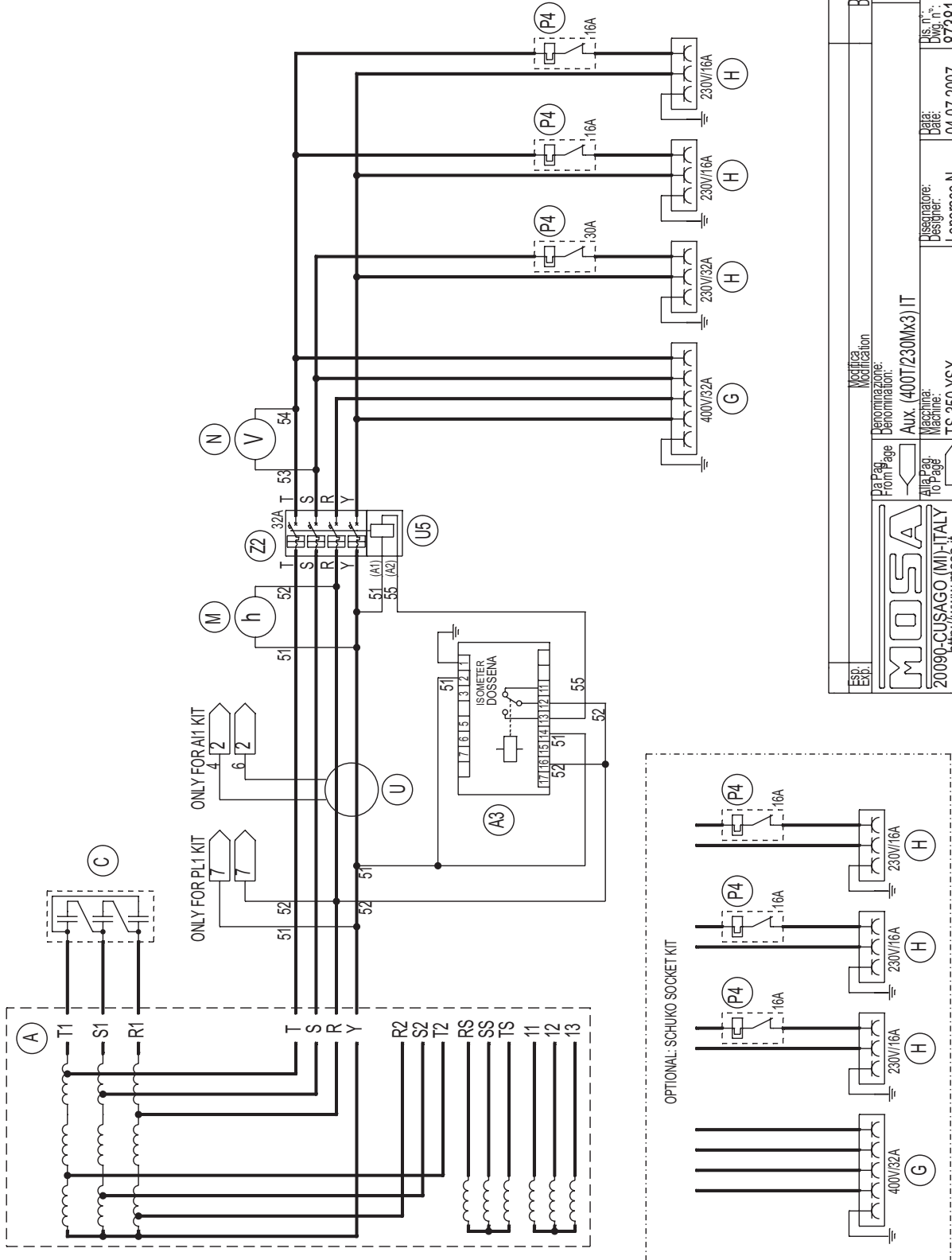

ESP. Exb.	Modifica	Data	Dis. Desi.	Appr. Abbr.
PaPag. From Page	Denominazione: Denominator:	Projecto: Project	Page n° of n°	Page n° of n°
AltaPag. to Page	Aux. (400T/230MX3) IT	87381.prg	3	7
Macchina: Machine:	TS 350 YSX	Dis. n.°: Dwg. n.°	87381	87381
http://www.mosa.it	Leporace N.	Disegnatore: Designer:	Approvato: Approved:	
		04.07.2007	87381	S.020
		Leporace		

La MOSA si riserva a termini di legge la proprietà del presente disegno con divieto di riprodurlo o comunicarlo a terzi senza sua autorizzazione.

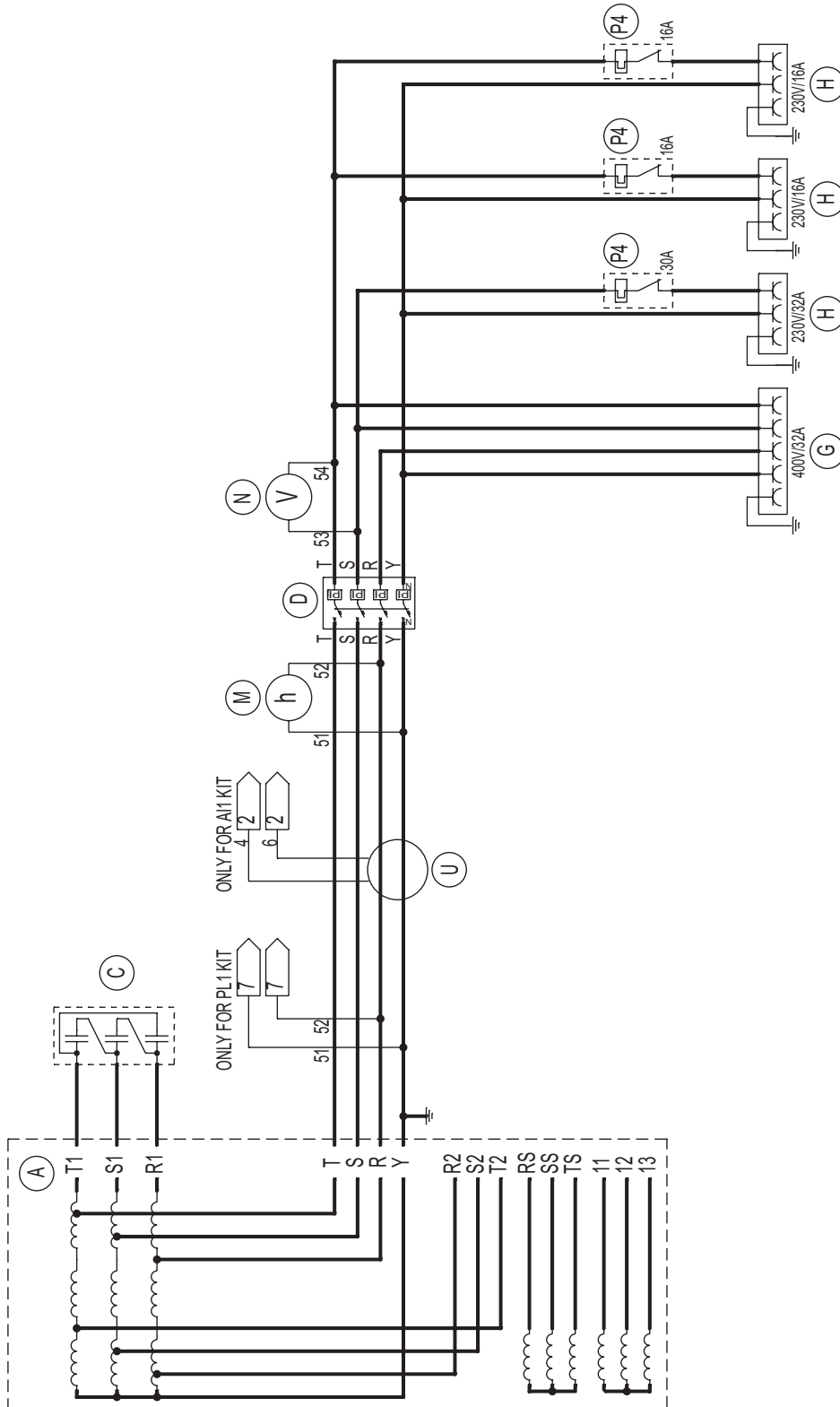

Esp. Exib.	Modifica Modification	Data Date	Dis. Desi. Page n°	Appr. Abrir. Page n°
			87384-p1rg	3
	Denominazione: Nomination:	Progetto: Project:	87384-p1rg	7
	Da Pag. From Page			
	Aux. (400T/230Mx3) DT			
	Alta Pag. To Page			
	Machine: Machine:	Dis. n.° Dwg. n.°	87384.S.020	7
	TS 350 YSX	Data: Date:	04.07.2007	Approved: Approved:
		Disegnatore: Designer:	Leporace N.	<i>[Signature]</i>

La MOSA si riserva a termini di legge la proprietà del presente disegno con divieto di riproduzione o comunicato a terzi senza sua autorizzazione.

10 9 8 7 6 5 4 3 2 1

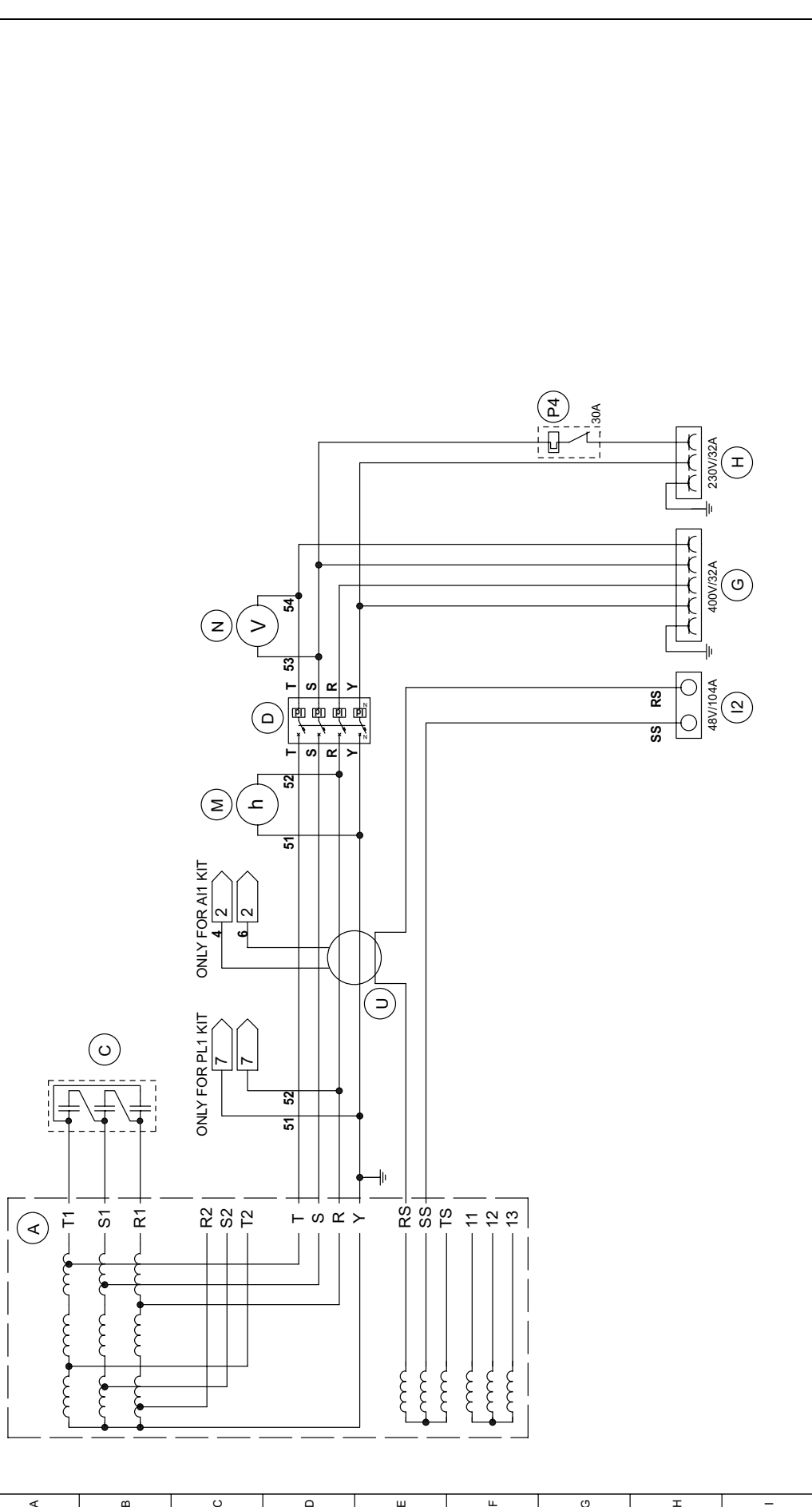

Esp. Eqp.	Modifica Modification	Data Date	Dis. Dess.	Appr. Appr.
	Denominazione: Denomination: Aux. (400T/230M/48M) DT	Progetto: Project: 87388.prg	Pag. n° Page n° 3	di n° of n° 7
	Macchina: Machine: TS 350 YSX	Disegnatore: Designer: Leporace N.	Data: Date: 04.07.2007	Dis. n° Dwg. n°: 87388.S.020
	 20090-CUSAGO (MI)-ITALY http://www.mosa.it	Approvato: Approver:		

La MOSA si riserva a termini di legge la proprietà del presente disegno con divieto di riprodurlo o comunicarlo a terzi senza sua autorizzazione.

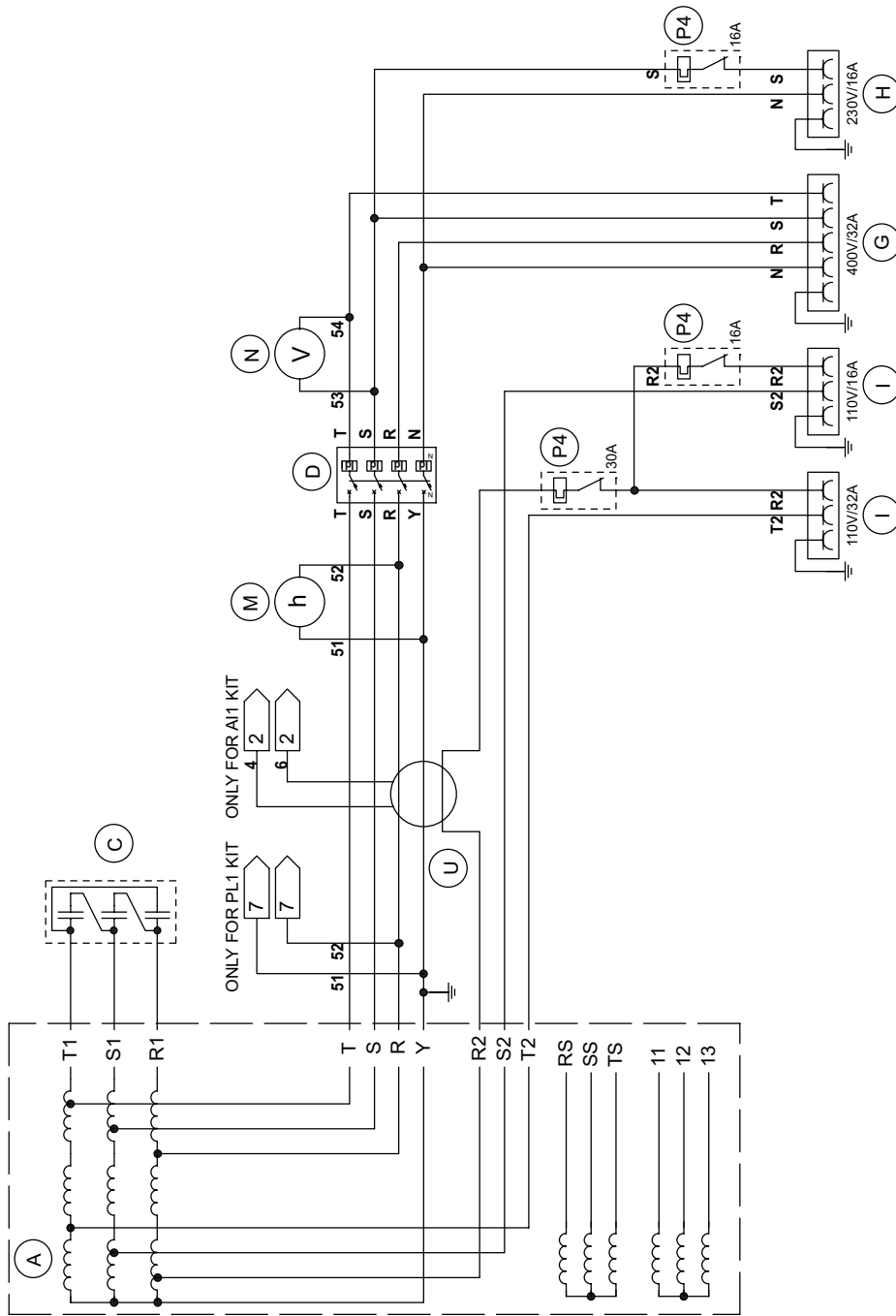

A		Sostituite prese 32A/230V e 110V/16A con prese 16A/230V e 32A/110V.		02.04.2008	N.L.
Exp.:	Modifica	Date	Dis.:	Appr.	
Exp.:	Modifica	Date	Dis.:	Appr.	
Da Pag. 1		Denominazione: 87386.prg		Pag. n° di n°	
From Page 1		Project: 87386.prg		Page n° of n°	
MOSA		Aux. (400T/230M/110CTEX2) DT		3	
20090-CUSAGO (MI)-ITALY		Macchina: 87386.S.020-A		7	
http://www.mosa.it		Leporace N. 11.07.2007		Dis. n°	
		Designer: 87386.S.020-A		Dwg. n°	
		Leporace N.		Approved:	
				Approved:	

La MOSA si riserva a termini di legge la proprietà del presente disegno con divieto di riprodurlo o comunicarlo a terzi senza sua autorizzazione.

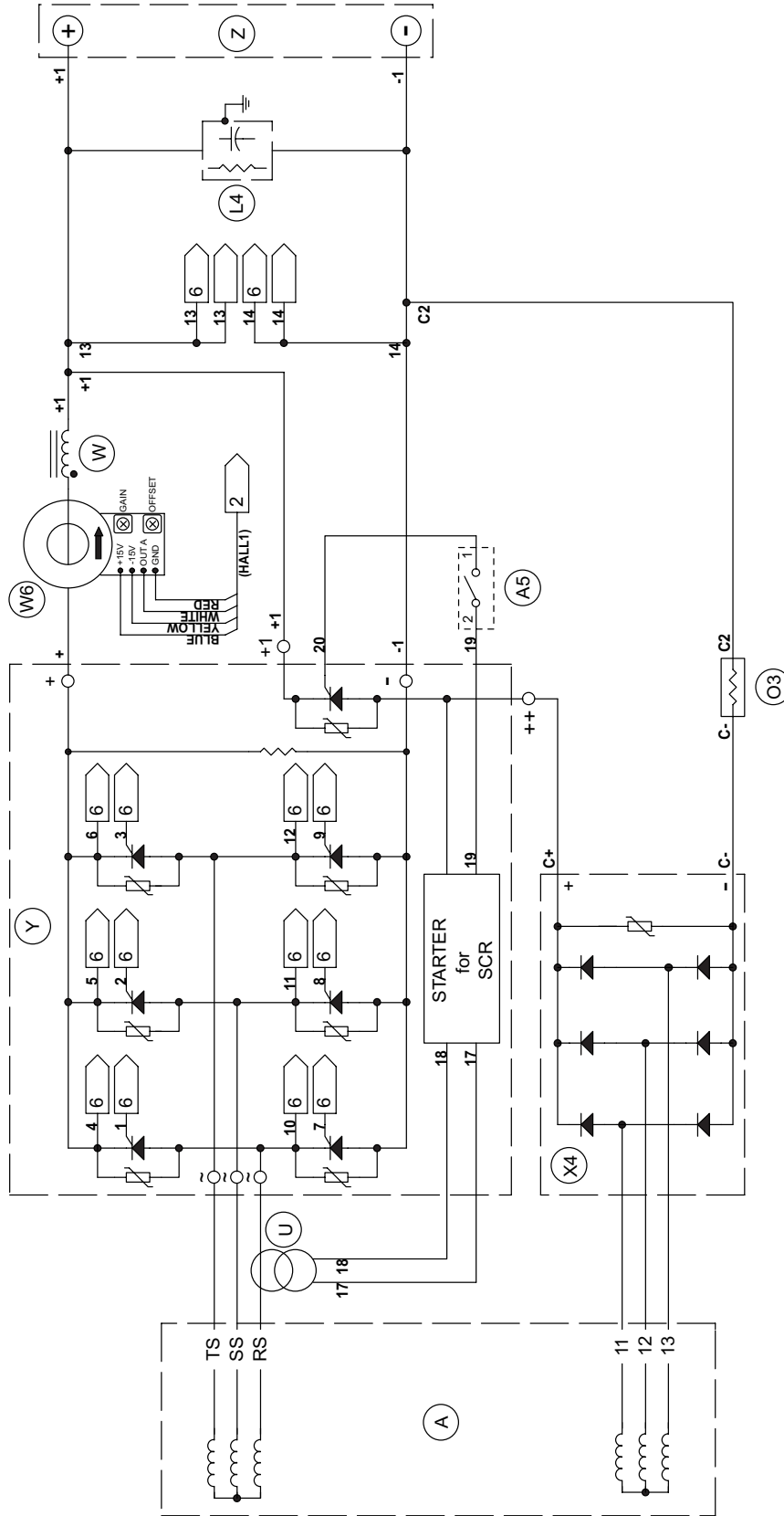

A		Modificato schema con nuova scheda auto idle (L8).		31.03.2008	N.L.
Exp.	Modifica	Date	Appr.		
Exp.	Modifica	Date	Appr.		
Da Pag. From Page	Denominazione: Denomination:	Progetto: Project:	Dis. n° of n°	4	7
6	Welding Power	87384.prg	Page n° of n°		
6	Macchina: Machine:	Dis. n°: Dwg. n°:	Approvato: Approves:		
6	20090-CUSAGO (MI)-ITALY	04.07.2007	87384.S.030-A		
6	http://www.mosa.it	Leporace N.			
La MOSA si riserva a termini di legge la proprietà del presente disegno con divieto di riprodurlo o comunicarlo a terzi senza sua autorizzazione.					

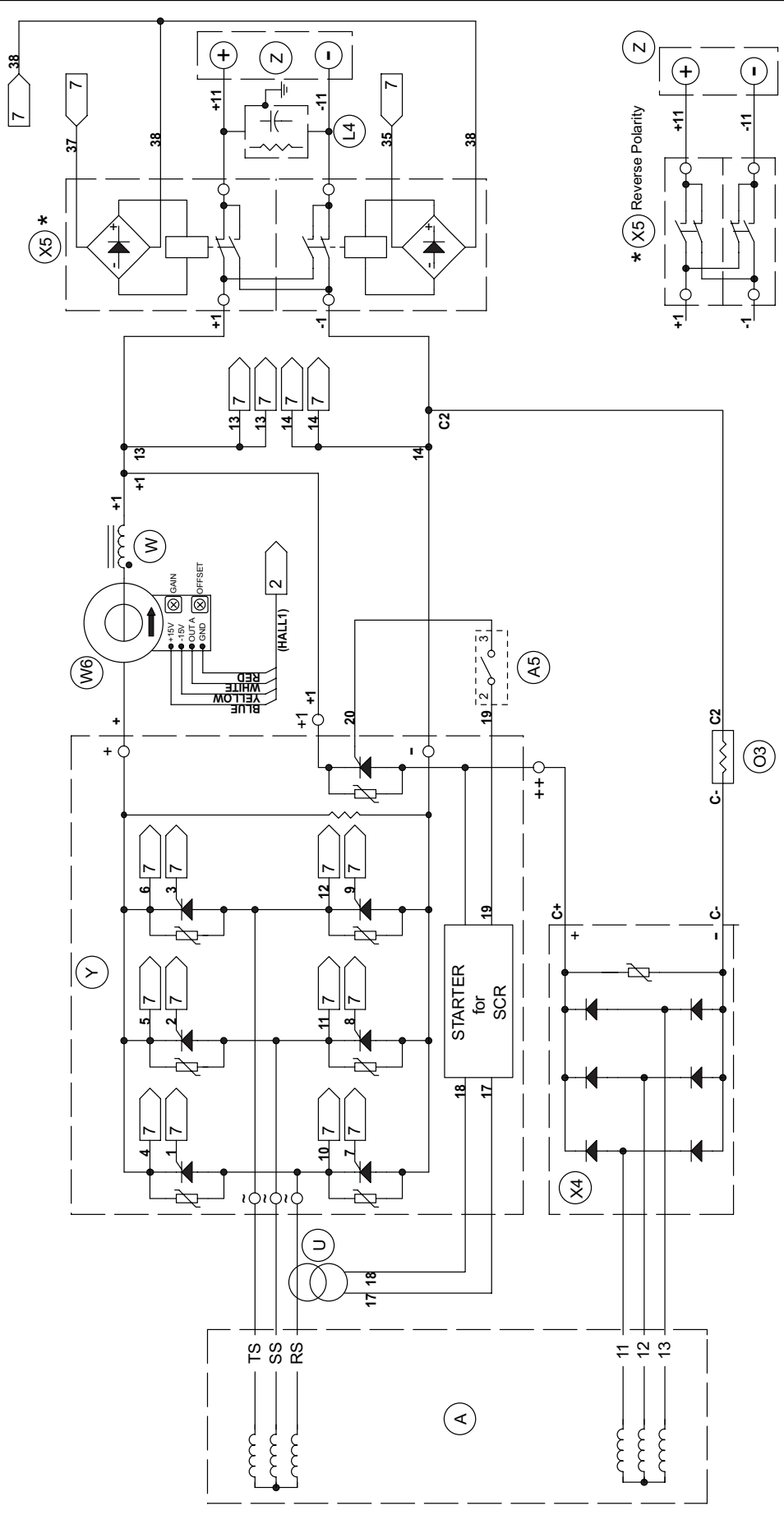

A		Modificato schema con nuova scheda auto idle (L8).		31.03.2008	N.L.
Exp. Esp.	Modifica	Data	Dis. Desi.	Appr.	
	Modificazion	Date	Projecto:	Page n°	5
			Project:	Page n°	7
			Project:	Project:	87384.prg
Da Pag. From Page	Denominazione: Denomination:	Disegnatore: Designer:	Data: Date:	Dis. n°: Deg. n°:	Approvato: Approved:
ⓂⓄⓈⓐ	Welding Power with PL 1 kit	Leporace N.	04.07.2007	87384.S.031-A	Use 10
20090-CUSAGO (MI)-ITALY http://www.mosa.it	Macchina: Machine: TS 350 YSX				

La MOSA si riserva a termini di legge la proprietà del presente disegno con divieto di riprodurlo o comunicarlo a terzi senza sua autorizzazione.

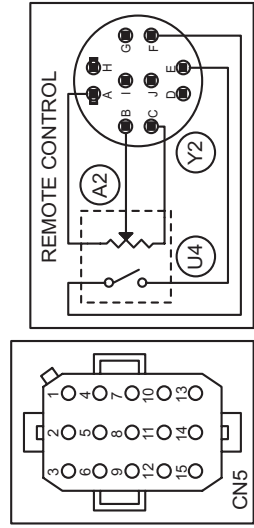
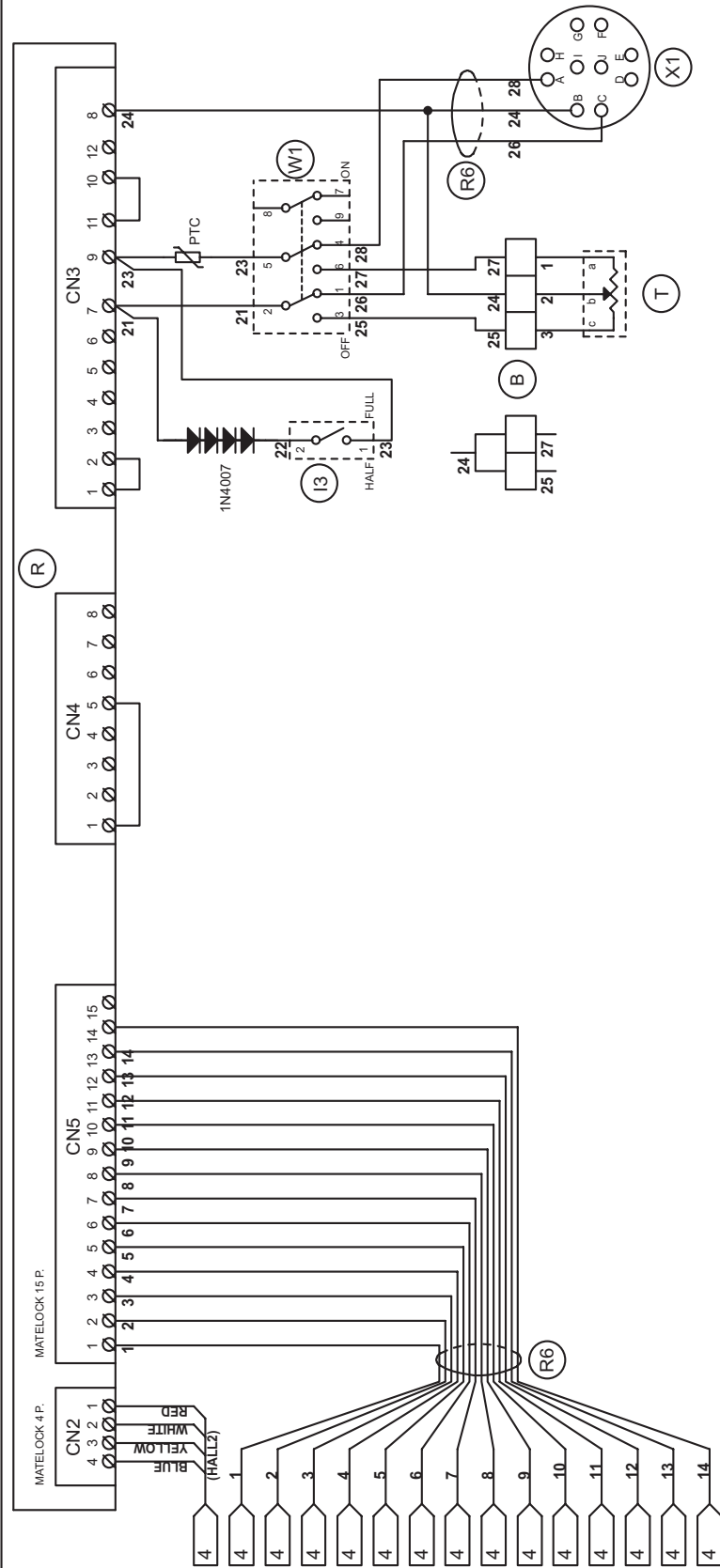

C	Aggiunto protezione (Termistor e) per evitare perdite di segnale sul comando a distanza.	27.10.2009	N.L.
B	Aggiunto diodo 1N4007	20.03.2009	N.L.
A	Modificato schema per nuova scheda auto idle.	31.03.2008	N.L.
Esp.:			
Exo.:			
MOSA 20090-CUSAGO (MI)-ITALY http://www.mosa.it		Denominazione: Denominations: Welding Power	Disegnatore: Designer: Leporace N.
Da Pag. From Page To Page To Page		Modifica Modification	Data Date 04.07.2007
Disegnatore: Designer: TS 350 YSX		Dis. n.° Dwg. n.° 87384.prg	Dis. n.° Dwg. n.° 87384.S.040-C
Propagato: Project: 87384.prg		Data Date 27.10.2009	Dis. n.° Dwg. n.° 87384.prg
Modifica Modification		Data Date 20.03.2009	Dis. n.° Dwg. n.° 87384.prg
Denominazione: Denominations: Welding Power		Data Date 31.03.2008	Dis. n.° Dwg. n.° 87384.prg
Disegnatore: Designer: Leporace N.		Data Date 04.07.2007	Dis. n.° Dwg. n.° 87384.S.040-C
Propagato: Project: 87384.prg		Data Date 27.10.2009	Dis. n.° Dwg. n.° 87384.prg
Modifica Modification		Data Date 20.03.2009	Dis. n.° Dwg. n.° 87384.prg
Denominazione: Denominations: Welding Power		Data Date 31.03.2008	Dis. n.° Dwg. n.° 87384.prg
Disegnatore: Designer: Leporace N.		Data Date 04.07.2007	Dis. n.° Dwg. n.° 87384.S.040-C

La MOSA si riserva a termini di legge la proprietà del presente disegno con divieto di riprodurlo o comunicarlo a terzi senza sua autorizzazione.

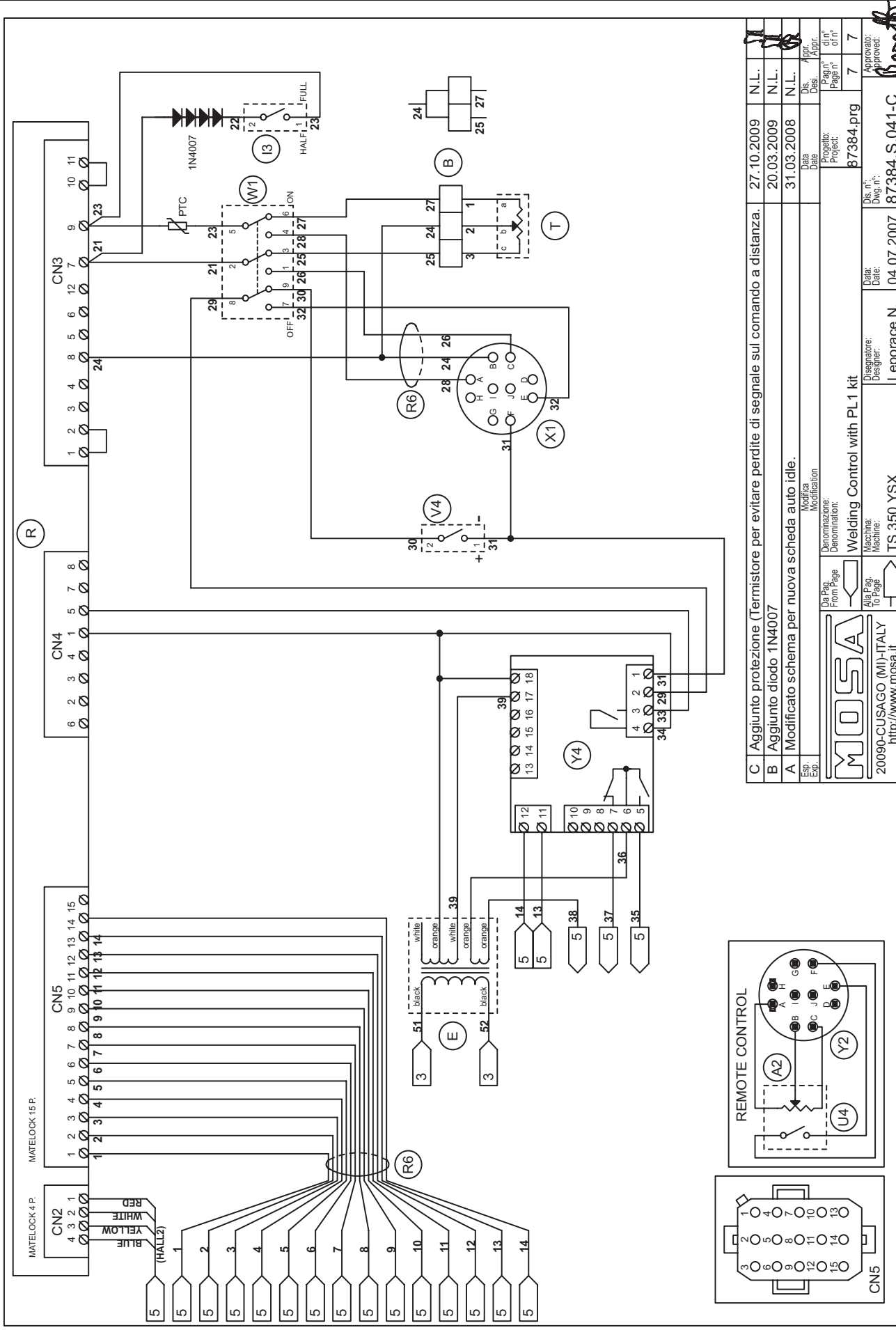

C	Aggiunto protezione (Termistore per evitare perdite di segnale sul comando a distanza.	27.10.2009	N.L.
B	Aggiunto diodo 1N4007	20.03.2009	N.L.
A	Modificato schema per nuova scheda auto idle.	31.03.2008	N.L.
Esp.:	Modifica	Data	Dis. n°
Exp.:	Modification	Date	Des. n°
Denominazione: Welding Control with PL1 kit Denomination:		Progetto: 87384.prg	di n°
Da Pag. From Page To Page		Data: 04.07.2007	di n°
Macchina: TS 350 YSX Machine:		Dis. n°: 87384.S.041-C	di n°
Designator: Leporace N. Designer:		Dis. n°: 87384.S.041-C	di n°
Mosa		Dis. n°: 87384.S.041-C	di n°
20090-CUSAGO (MI)-ITALY http://www.mosa.it		Dis. n°: 87384.S.041-C	di n°

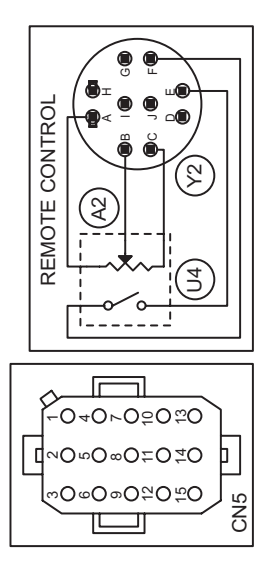

La MOSA si riserva a termini di legge la proprietà del presente disegno con divieto di riproduzione o comunicato a terzi senza sua autorizzazione.

MOSA guarantees that any request for spare parts will be satisfied.

To keep the machine in full working order, when replacement of MOSA spare parts is required, always ask for genuine parts only.

The requested data are to be found on the data plate located on the machine structure, quite visible and easy to consult. *

When ordering the spare parts, it is recommended to indicate:

- 1) * serial number
- 2) * model of welder and/or generating set
- 3) ◆ n. table
- 4) ◆ n. position
- 5) quantity

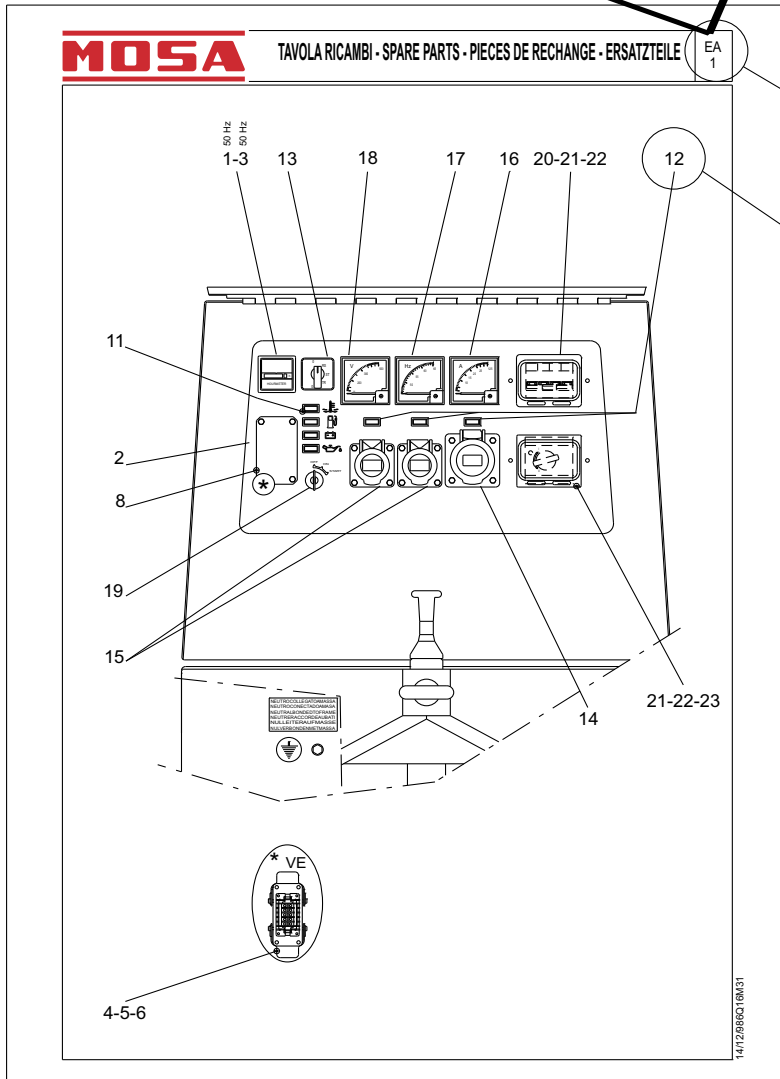
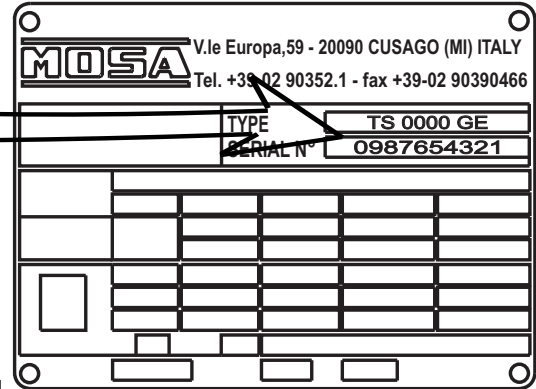

ABBREVIATIONS AND SYMBOLS:

- (EV) When ordering, specify the engine type and the auxiliary voltage
- (ER) Engine with recoil starter only
- (ES) Engine with electric starter only
- (VE) E.A.S version only.
- (QM) When ordering, specify the length in meters
- (VS) Special version only
- (SR) By request only

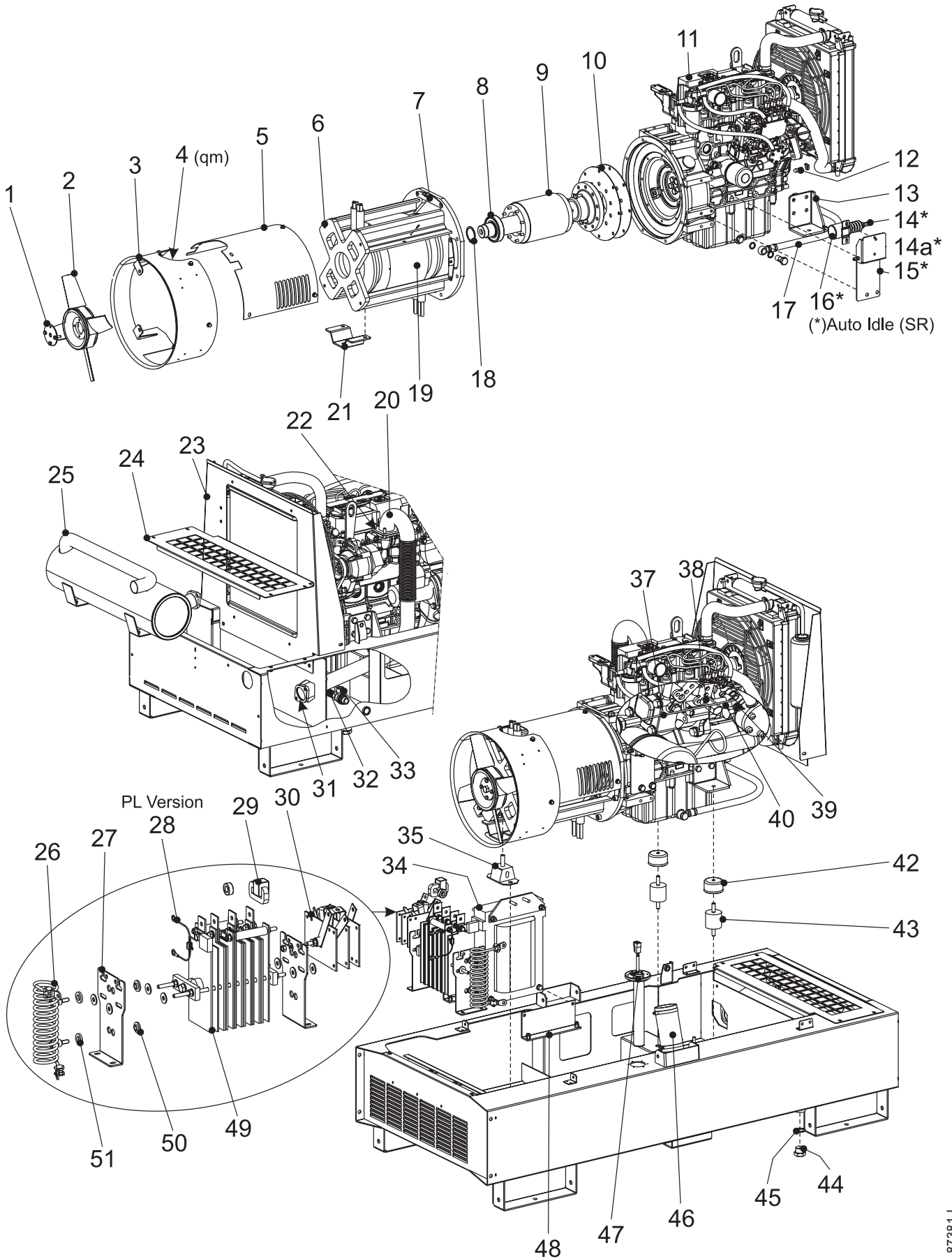

Pos.	Rev.	Cod.	Descr.	Note
1		M107301390	ANELLO / RING FIXING FAN	
2		M700406020	VENTOLA / FAN	
3		M700406010	CONVOGLIATORE ARIA / AIR CONVEYOR	
4		M107509005	GUARNIZIONE / GASKET	qm
5		M773748222	COPERTURA ALTERNATORE / Cover alternator	
6		M700403010	CARCASSA STATORE / HOUSING	
7		M773748224	STAFFA SUPP. COPERTURA ALT. / BRACKET	
8		M1001060	CUSCINETTO / BEARING	
9		M773703030	ALBERO CON ROTORE / SHAFT WITH ROTOR	
10		M773713012	DISCO ALBERO ROTORE / SHAFT WITH ROTOR DISC	NSM
11		M773812200	MOTORE YANMAR 3TNV76 / YANMAR ENGINE 3TNV76	
12		M773812019	CAPPUCCIO / CUP	
13		M773812034	STAFFA SUPPORTO MOTORE / BRACKET	
14		M107302860	GHIERA / RING NUT	SR-Kit Auto Idle
14 a		M305519056	TIRANTE / TIE ROD	SR-Kit Auto Idle
15		M773709102	PIASTRA SUPP. SOLENOIDE ACC. / SOLENOID SUPPORT PLATE	SR-Kit Auto Idle
16		M873819050	ELETTROMAGNETE / SOLENOID	SR-Kit Auto Idle
17		M773812212	TUBO SCARICO OLIO / OIL EXHAUST TUBE	
18		M6050050	ANELLO SEEGER / RING, SEEGER	
19		M873763020	STATORE / STATOR 400T230M110CTE	
20		M773810566	TUBO SCARICO / EXHAUST TUBE	
21		M773723101	STAFFA SUPPORTO ALTERNATORE / BRACKET	
22		M773812071	GUARNIZIONE SCARICO PER MOTORE / GASKET, ENGINE EXHAUST	
23		M773818215	PARATIA SCARICO ARIA MOTORE / ENGINE INLET COVER	
24		M773818230	GRIGLIA PROT. SILENZIATORE SCARICO / EXHAUST PROTECTIVE GRILL	
25		M773812050	SILENZIATORE SCARICO / EXHAUST MUFFLER	
26		M766704010	RESISTORE DI POTENZA / POWER RESISTANCE	
27		M773715091	STAFFA / BASE DIODE SUPPORT	
28		M873769895	RESISTENZA CABLATA / WIRED RESISTOR	PL Version
29		M107659871	TRASFORMATORE SENSORE AUX / TRANSFORMER AUX	
30		M366105090	PONTE DI BASE / BASE CURRENT BRIDGE	
31		M305232071	GUARNIZIONE PER FLANGIA / GASKET X FAN	
32		MJJ0062292	NIPPLO OLEODINAMICO 1/2" G / OLEODYNAMIC NIPPLE	
33		MJJ0062025	RUBINETTO M-F 1/2" G / VALVE	
34		M866004100	REATTORE DI LIVELLO / LEVEL INDUCTOR	
35		M105612070	ANTIVIBRANTE (40x50) / VIBRATION-DAMPER (40x50)	
37		M773709056	FUNE COMANDO ELETTROMAGNETE / SOLENOID TIE-ROD	
38		M773702244	MORSETTO PER FUNE COMANDI / TERMINAL	
39		M105111450	MORSETTO / TERMINAL	
40		M105111460	MOLLA / SPRING	
42		M307012037	PROTEZIONE ANTIVIBRANTE / PROTECTION, VIBRATION-DAMPER	
43		M773721035	ANTIVIBRANTE / VIBRATION DAMPER	
44		M308101262	TAPPO SCARICO SERBATOIO / FUEL TANK CAP	
45		M308102023	GUARNIZIONE / GASKET	
46		M6095030	TUBO GOMMA / PIPE	
47		M764409975	SENSORE LIVELLO CARBURANTE(L=225) / FUEL LEVEL SENSOR	
48		M209714110	SUPPORTO REATTANZA / SUPPORT, REACTOR	
49		M873765100	PONTE DIODI / DIODE BRIDGE	
50		M309015043	RONDELLA / WASHER	
51		M309014013	DISTANZIALE / SPACER	

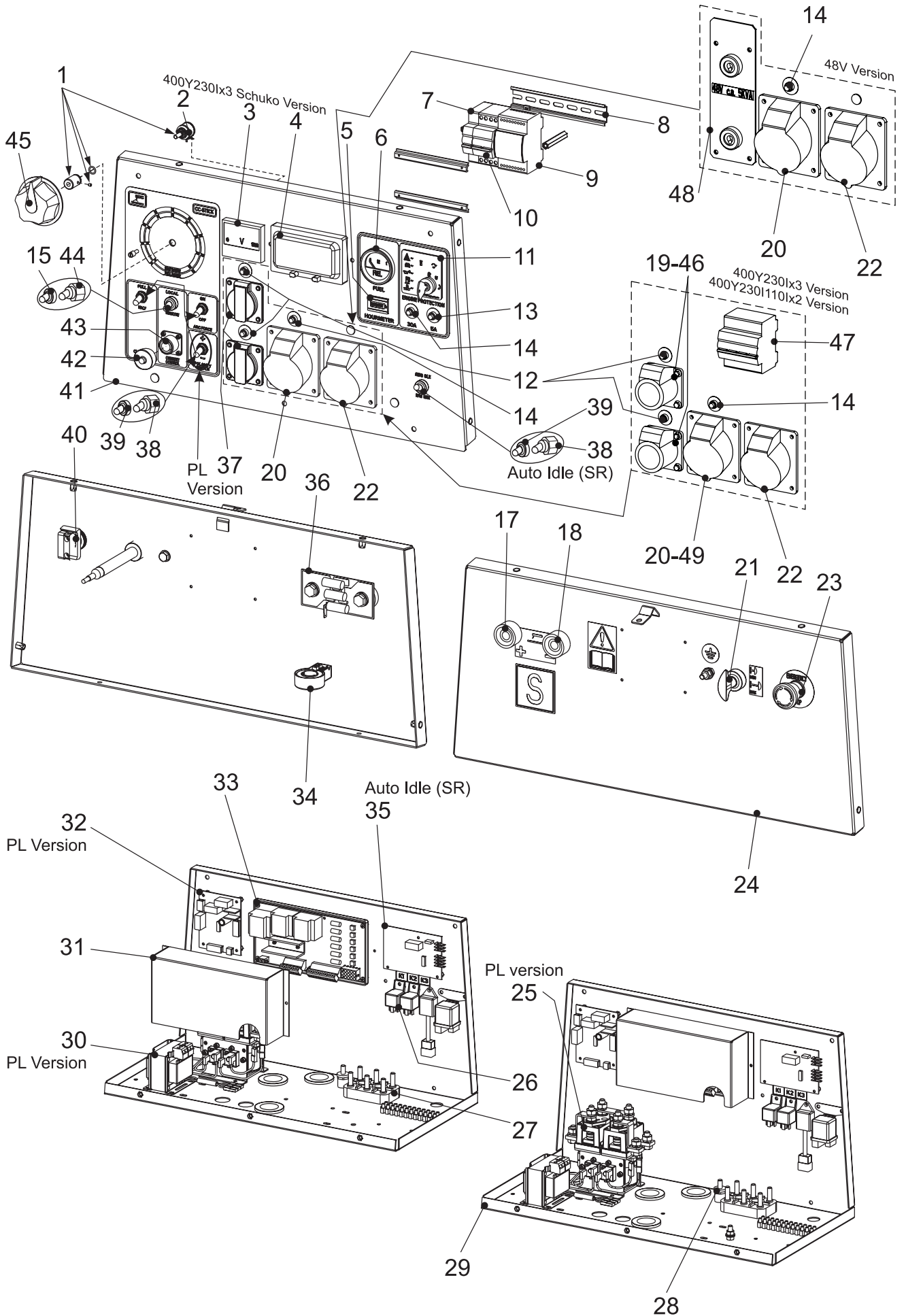

Pos.	Rev. Cod.	Descr.	Note
1	M836709715	POTENZIOMETRO / WELDING CURRENT REGULATOR	
2	M0000836709701	POTENZIOMETRO / WELDING CURRENT REGULATOR	
3	M105111550	VOLTMETRO FS 500V / VOLTMETER	
4	M220117130	COPERCHIO PROTEZIONE / PROTECTION COVER	
5	M105511810	CONTAORE 230V 50Hz IP65 / HOURMETER 230V 50Hz IP65	
6	M325507210	INDICATORE LIVELLO CARBURANTE / FUEL LEVEL GAUGE	
7	MIB0179706	BOBINA DI SGANCIO 220V / Manca la descrizione aggiuntiva	
8	M1243020	GUIDA PER MORSETTIERA / TERMINAL GUIDE	
9	M740557105	SORVEGLIATORE D'ISOLAMENTO / INSULATING ALARM	
10	MKJ0187325	INT.MAGNET. 4P 32A-C COMPACT(PI 4.5KA) / CIRCUIT BREAKER	
11	M265509770	UNITA' CONTROLLO MOTORE EP7 / UNIT ENGINE CONTROLEP7	
12	M155307107	DISGIUNTORE TERMICO 15A-250V / THERMAL SWITCH 15A-250V	
13	M352007109	PROTEZIONE TERMICA 5A / THERMOPROTECTION	
14	M873407107	DISGIUNTORE TERMICO 30A/250V / CIRCUIT BREAKER 30A/250V	
15	M102042740	CAPPUCCIO / CAP	
17	M102301310	PRESA DI SALDATURA (+) / WELDING SOCKET (+)	
18	M102044400	PRESA DI SALDATURA (-) / WELDING SOCKET (-)	
19	M307017240	PRESA 220V 16A / EEC SOCKET 16A, 220V 2P+T	400Y230lx3 / 400Y230I110lx2 Version
20	M105111520	PRESA CEE 220V MONOF. 2POLI+T / EEC SOCKET SINGLE-PH.220V 2P+T	
21	M773709105	COMANDO ACCELERATORE MOTORE / ENGINE ACCELERATOR LEVER	
22	M105111510	PRESA CEE 380V TRIFASE / EEC SOCKET THREE-PHASE 380V	
23	M744507219	PULSANTE STOP D'EMERGENZA / EMERGENCY PUSH BUTTON STOP	
24	M773817205	PANNELLO FRONTALE (INF.) / FRONT PANEL	
25	M0000873797420	TELERUTTORE INVERS. POLARITA(comp.l.) / PLARITY CHANGE CONTACTOR	PLVersion
26	M306479199	RELE' AVV. ELETTRICO / RELAY, ELECTRIC START	
27	M105111830	MORSETTIERA / TERMINAL BOARD	
28	M208029104	DISTANZIALE ISOLANTE / SPACER	
29	M773817010	SCATOLA ELETTRICA / ELECTRIC BOX	
30	MED0109870	TRASFORMATORE AUSILIARIA / WELDING PCB PROTECTION BOX	PL Version
31	M766019654	SCATOLA PROTEZ. SCHEDA SALD. / PCB POLARITY INVERTER	
32	M366609690	SCHEDA COMANDO INVERT.POLARITA / WELDING CONTROL PCB	PL Version
33	M766029800	SCHEDA CONTROLLO SALDATURA / WELDING CONTROL UNIT	
34	M773815107	SENSORE DI HALL / HALL SENSOR	
35	M773819638	SCHEDA AUTO IDLE / AUTO IDLE PCB	SR-Kit Auto Idle
36	M700409860	UNITA' FILTRO ANTIDISTURBI / ANTIJAMMING FILTER	
37	M259107241	PRESA SCHUKO 16A 230V - 2P+T / SOCKET SCHUKO 16A 230V 2P+T	
38	M282009741	INTERRUTTORE UNIPOLARE 15A / UNIPOLAR SWITCH	
39	M282009962	CAPPUCCIO ISOLANTE x INTERRUT. / CAP	
40	M265507237	CONTATTO NORMALMENTE APERTO / CONTACT N. O.	
41	M773817020	PANNELLO FRONTALE / FRONT PANEL	
42	M765009911	CAPPUCCIO X CONNETTORE / CONNECTOR CAP	
43	M765009910	CONNETTORE / CONNECTOR	
44	M107509902	COMMUTATORE TRIPOLARE / TRIPOLAR SWITCH	
45	M107509702	MANOPOLA REG.CORRENTE SALDAT. / KNOB,WELDING CURRENT REGULAT.	
46	M307047250	PRESA CEE / EEC SOCKET 110V 16A 2 P+T	400Y230I110lx2 Version
47	M105111540	Vedi Cod./ See part no 219937105	400Y230lx3 / 400Y230I110lx2 Version
48	M101131220	PRESA SALDATURA NERA/ SOCKET	
49	M105111530	PRESA CEE 32A 110V 2P+T / EEC SOCKET 110V 32A 2P+T	400Y230I110lx2 Version

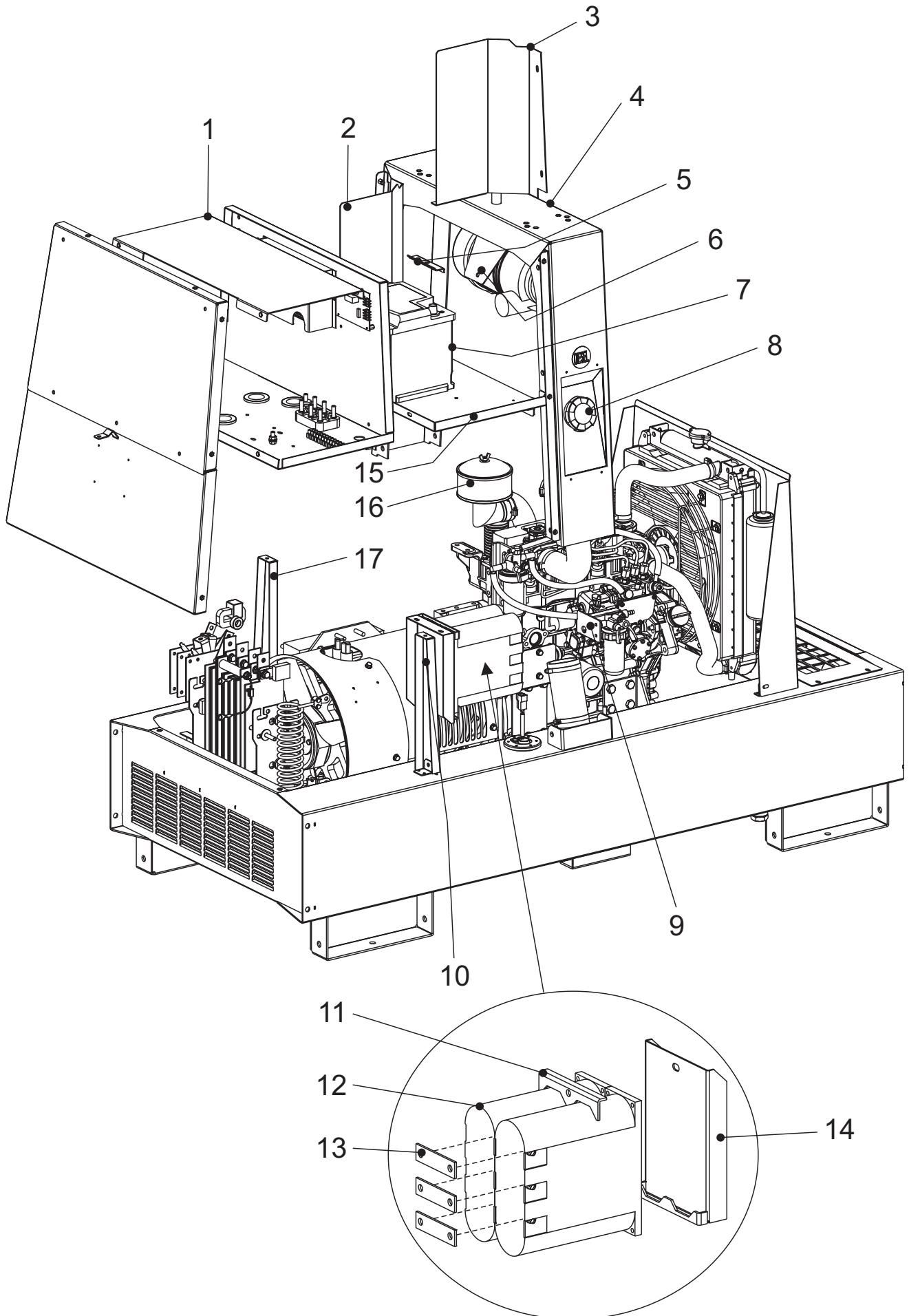

<i>Pos.</i>	<i>Rev.</i>	<i>Cod.</i>	<i>Descr.</i>	<i>Note</i>
1		M773817015	COPERCHIO SCATOLA ELETTRICA	
2		M773818315	PARATIA ASPIRAZIONE ARIA SX	
3		M773818314	PARATIA ASPIRAZIONE ARIA DX	
4		M773811100	ROLL-BAR	
5		M400409154	STAFFA FISSAGGIO BATTERIA	
6		M773812122	STAFFA SUPP. FILTRO ARIA	
7		M773749150	BATTERIA	
8		M342202026	TAPPO SERBATOIO	
9		M841552241	STAFFA SUPP.PRE-FILTRO GASOLIO	
10		M773818239	TRAVERSINO DX RINF.PARATIA ALTER.	
11		M209719882	STAFFA BOX CONDENSATORI	
12		M107019880	BOX CONDENSATORI	
13		M107509041	SBARRETTA BOX CONDENSATORI	
14		M784109887	PIASTRA FISS.BOX COND.(COMPL.)	
15		M873818290	PARATIA SUP. ALTERNATORE	
16		M773812145	PREFILTRO A CICLONE CON CURVA	
17		M773818240	TRAVERSINO SX RINF.PARATIA ALTER.	

<i>Pos.</i>	<i>Rev.</i>	<i>Cod.</i>	<i>Descr.</i>	<i>Note</i>
1		M773817015	ELECTRICAL BOX COVER	
2		M773818315	LEFT SIDE COVER FOR AIR INLET	
3		M773818314	RIGHT SIDE COVER FOR AIR INLET	
4		M773811100	ROLL-BAR	
5		M400409154	BATTERY BRACKET	
6		M773812122	BRACKET AIR FILTER SUPPORT	
7		M773749150	BATTERY	
8		M342202026	CAP, FUEL TANK	
9		M841552241	BRACKET DIESEL PRE-FILTER SUPPORT	
10		M773818239	RIGHT SUPPORT FOR ALTERN. BRACKET	
11		M209719882	CAPACITOR BOX BRACKET	
12		M107019880	CAPACITOR BOX	
13		M107509041	CONNECTING PLATE-CAPACITOR BOX	
14		M784109887	SUPPORT BRACKET REACTOR	
15		M873818290	ALTERNATOR TOP BULKHEAD	
16		M773812145	AIR PRE-FILTER	
17		M773818240	LEFT SUPPORT FOR ALTERN. BRACKET	

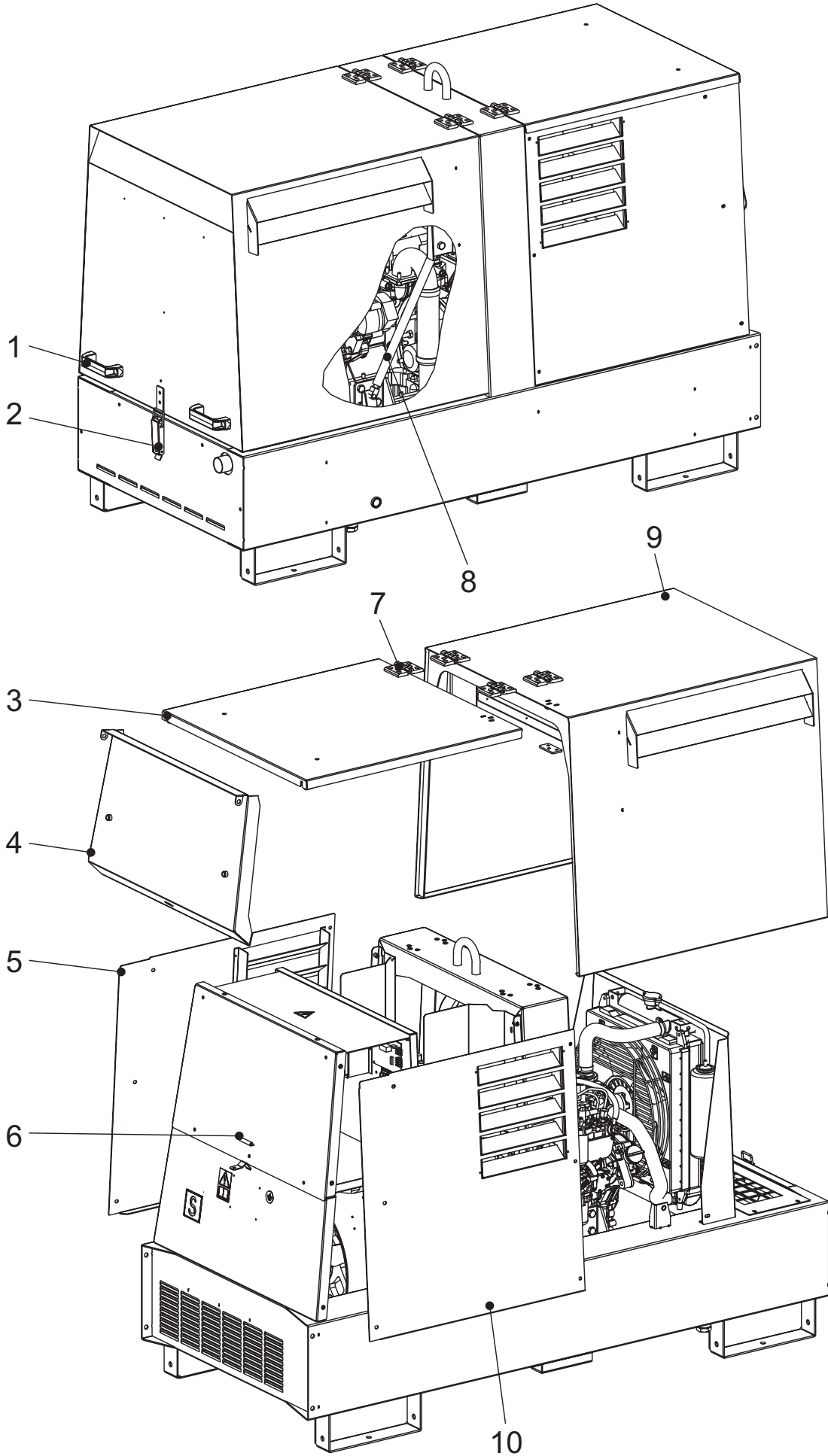

<i>Pos.</i>	<i>Rev.</i>	<i>Cod.</i>	<i>Descr.</i>	<i>Note</i>
1		M343339601	MANIGLIA	
2		M107300180	CHIUSURA COMPL.A LEVA	
3		M773818021	COPERCHIO CARENATURA ANT. (COMPL.)	
4		M773818100	COPERCHIO FRONTALE	
5		M773818015	FIANCATA SX CAREN.ANT. (COMPL.)	
6		M102042870	MOLLA	
7		M744508140	CERNIERA PER FIANCATA	
8		M209508115	PISTONE SOSTEGNO	
9		M773818035	CARENATURA POSTERIORE	
10		M773818010	FIANCATA DX CAREN.ANT. (COMPL.)	

<i>Pos.</i>	<i>Rev.</i>	<i>Cod.</i>	<i>Descr.</i>	<i>Note</i>
1		M343339601	KNOB	
2		M107300180	LATCH	
3		M773818021	FRONT HOUSING COVER (COMPL.)	
4		M773818100	FRONT COVER	
5		M773818015	FRONT COVER (LEFT)	
6		M102042870	SPRING	
7		M744508140	LATCH	
8		M209508115	SUPPORT, REAR COVER	
9		M773818035	COVER, REAR	
10		M773818010	FRONT COVER (RIGHT)	

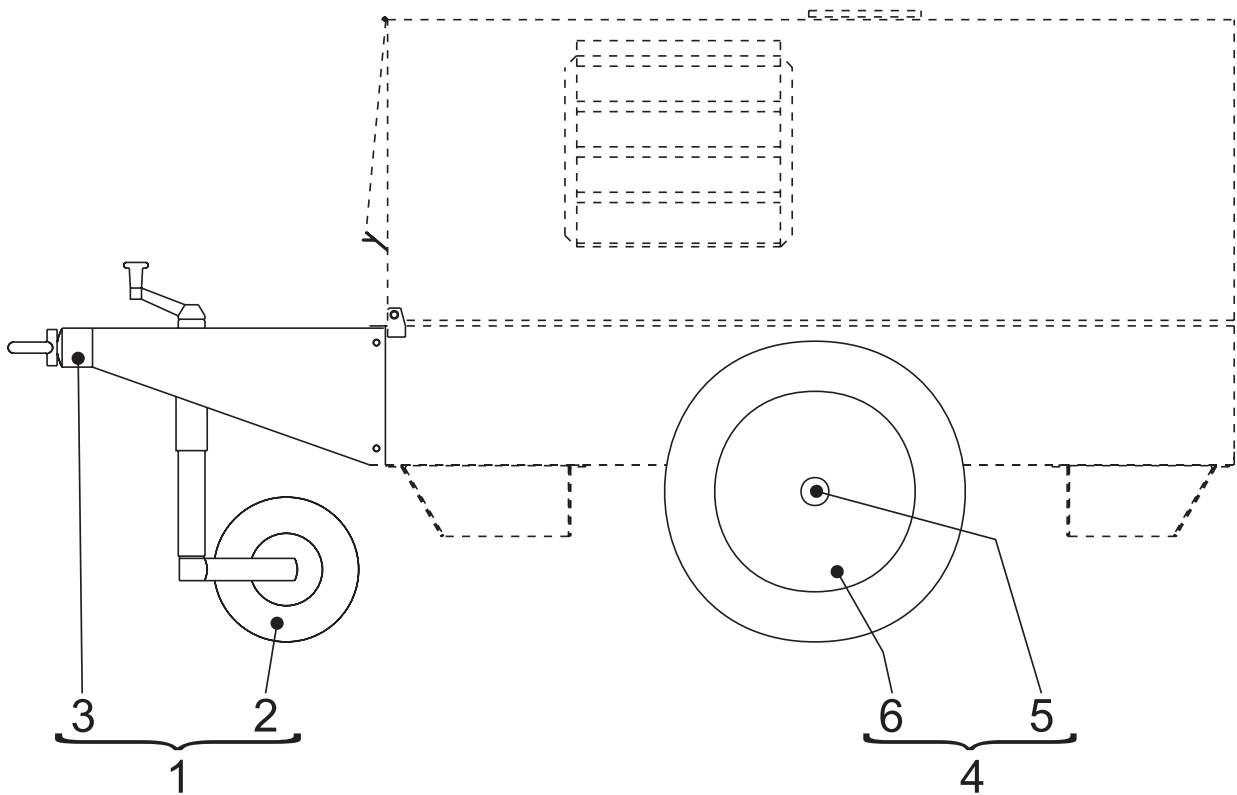

Pos.	Rev.	Cod.	Descr.	Descr.
1		0000217600141	GR.TIMONE,PIEDE X TRAINO LENTO	KIT SITE TOW
2		102351750	PIEDE DI STAZIONAMENTO	PARKING STAND
3		207401150	TIMONE	TOW BAR
4		0000217600142	GR. ASSALE, RUOTE TRAINO LENTO	KIT SITE TOW
5		207401160	ASSALE	AXLE
6		102351740	RUOTA	WHEEL

RC2

RC2/90°

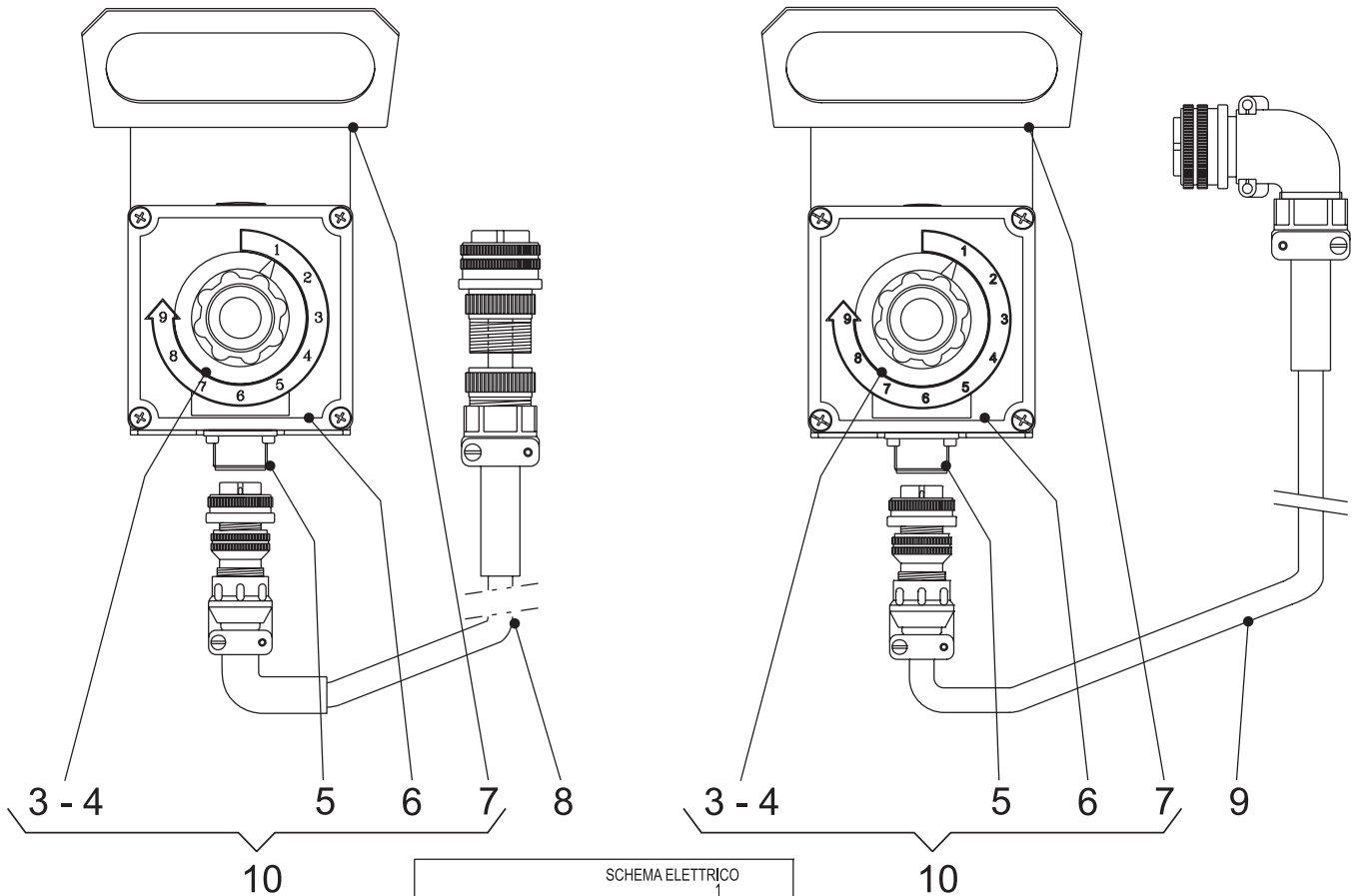

SCHEMA ELETTRICO
 ELECTRICAL DIAGRAM
 ELECTRIQUE SCHEMA
 ELEKTRISCHES SCHEMA

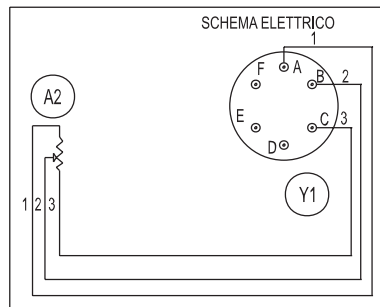

Pos.	Cod.	Descr.	Descr.
3	M308300543	MANOPOLA REGOLAZIONE COMPL.	KNOB, REGULATOR COMPLETE
4	M836709715	POTENZIOMETRO	WELDING CURRENT REGULATOR
5	M836709910	CONNETTORE FEMMINA	FEMALE CONNECTOR
6	M836700524	SCATOLA	BOX
7	M308309900	MANIGLIA COMANDO A DISTANZA	REMOTE CONTROL HANDLE
8	M0000KD0259904	CAVO COMANDO DISTANZA	REMOTE CONTROL CABLE
9	M936829904	CAVO COMANDO DISTANZA	REMOTE CONTROL CABLE
10	M936840555	COMANDO RC2 SENZA CAVO	RC2 REMOTE CONTROL

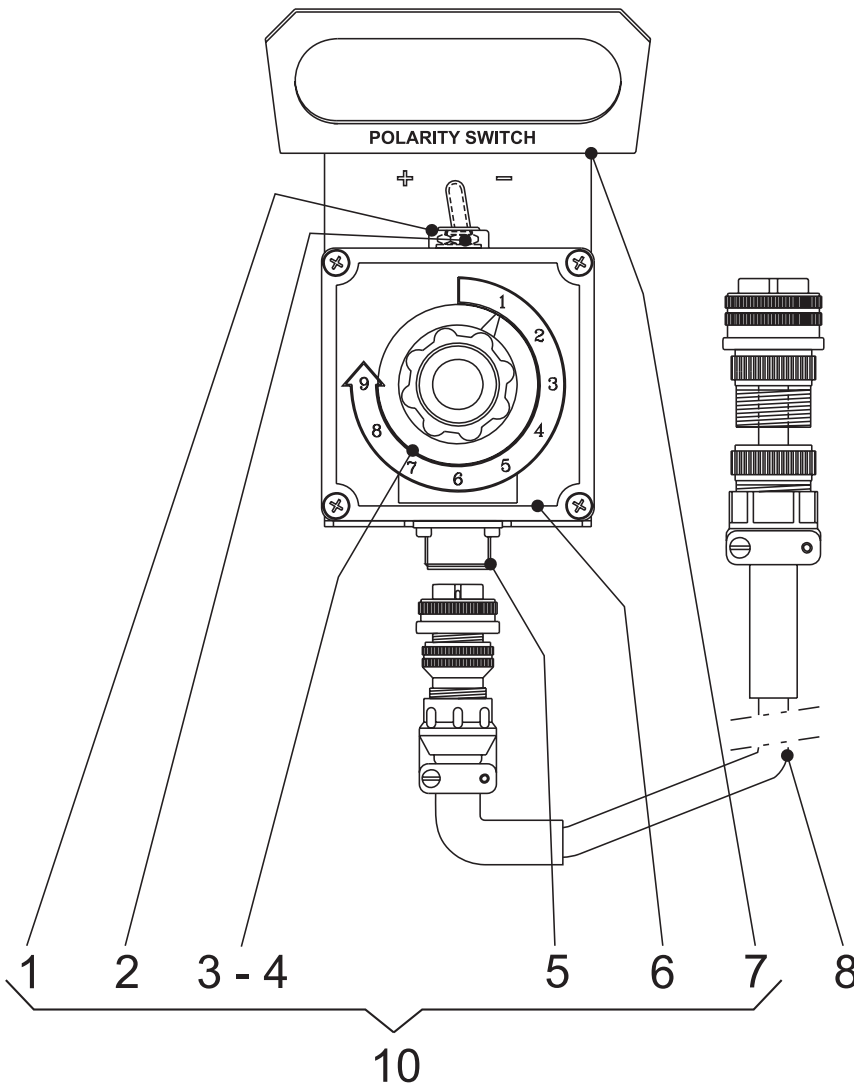

SCHEMA ELETTRICO
 ELECTRICAL DIAGRAM
 ELECTRIQUE SCHEMA
 ELEKTRISCHES SCHEMA

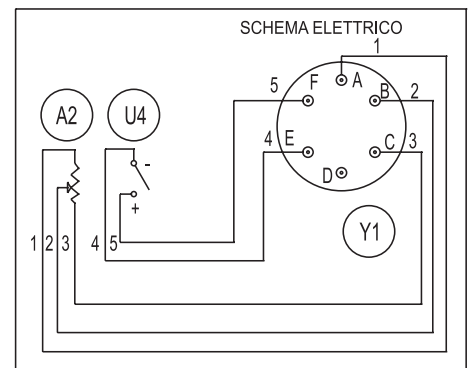

Pos.	Cod.	Descr.	Descr.
1	M282009962	CAPPUCCIO	CAP
2	M282009741	COMMUTATORE	COMMUTATOR
3	M308300543	MANOPOLA REGOLAZIONE COMPL.	KNOB, REGULATOR COMPLETE
4	M836709715	POTENZIOMETRO	WELDING CURRENT REGULATOR
5	M836709910	CONNETTORE FEMMINA	FEMALE CONNECTOR
6	M836700524	SCATOLA	BOX
7	M308309900	MANIGLIA COMANDO A DISTANZA	REMOTE CONTROL HANDLE
8	M0000KD0259904	CAVO COMANDO DISTANZA	REMOTE CONTROL CABLE
10	M936860555	COMANDO RC1/RCPL SENZA CAVO	RC1/RCPL REMOTE CONTROL

MOSA

GRUPPI ELETTROGENI

MOTOSALDATRICI

WWW.MOSA.IT

MOSA div. della BCS S.p.A.
Stabilimento di Viale Europa, 59
20090 Cusago (MI) Italia

Tel. + 39 - 0290352.1
Fax + 39 - 0290390466



ISO 9001:2008 - Cert. 0192