

















# UL Ti MATE 80- 55W- Xenon

- \*The **UL Ti MATE 80-55w Xenon** is a “ Screwed Thru-Hull” underwater light .
- \*Never feel trapped by this fixture, the internal part with lamp and ignitor can be easily removed for servicing and upgrades without the hassle of hauling your boat. .
- \*With 4,800 lumens of light power and it's 60 degree beam angle, the **UL Ti MATE 80-Xenon** is recommended for GRP/Fiberglass and Wooden hull boats up to 25 meter.
- \*The light must be installed below the waterline and the boat must be hauled out for installation.
- \*Distance between lights can vary from 1m (transom) to 3 meters (port & starboard) apart for the best illumination.
- \*The light has a sealed integral igniter which makes it safer, and allows the ballast to be located away from the bilge area. The fixture can also be fitted with a wide beam lens and is also available in an extended version.
- \*With complete Lloyd's Register Approval, and ABS Design Appraisal on all components, the **UL Ti MATE 80 Xenon** has been installed on some ten thousand of coastal power boats world wide.

 <p><b>Maintenance</b> Inside the Hull</p>		<p><b>Hull Material</b>  Fiberglass/Wood</p>
 <p><b>Control Option</b> On/Off switched</p>		<p><b>Boat Size</b>  Up to 25m</p>
 <p><b>Driver</b> Remote</p>		<p><b>Lumens</b>  Max 4,800</p>
 <p><b>Lens</b> Borosilicate Glass</p>		<p><b>Kelvin</b>  7,000K</p>
 <p><b>Power</b> 12-24 vdc</p>	<p><b>Beam Angle</b>  60 Degrees</p>	
 <p><b>Installation</b> Thru- Hull</p>	 <p>AVAILABLE YES</p>  <p>AVAILABLE FILTERS</p>	 



# UL Ti MATE 80 Xenon 55w

## Mounting

Hull Material	GRP / Fiberglass
Boat size	Up to 25m/up to 90 Feet
Spacing	1m to 3m (Port & Starboard)
Beam Angle	60°+ degree
Installation Angles	Flush

## Technical

Lumens	4,800
Kelvin	7,000
Typical Bulb Life Expectancy	3,000 hrs
Min-Max Operating Voltage	12 - 24V DC
Current / Amp draw	6.4 - 2.5 amps
Ballast Type	External
Ballast Output	N/A
Control Options	On / Off switch

## Physical

Length of fixture	Standard:	129mm/5"
	Extended:	184mm/7.25"
Diameter of fixture		80mm/3.14"
Profile (height) of fixture		5mm/0.2"
Removal Space Required		160mm/6.5"
Total weight		1kg/2.2 lbs
Cable Length		Custom
Hole Cut-out		61mm
Material		5083 Aluminium / Nickel Coated AB2 Bronze
Lens		Borosilicate Glass
Max Hull thickness		65mm

## Color

White



White



## Part Number

S02652-12V

S02652-24V

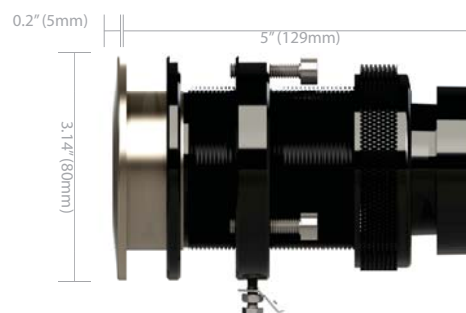

Your Local Dealer



© 2017 Underwater Lights Limited All Rights Reserved.  
Underwater lights limited reserves the right to change specifications without notice.

The Great Dunton Forge, London Road  
Dunton Green, Sevenoaks, Kent TN13 2TD UK  
T: +44 (0) 1732 455753 • F: +44 (0) 1732 743233  
E: [uwl@underwaterlights.com](mailto:uwl@underwaterlights.com)

[www.underwaterlights.com](http://www.underwaterlights.com)

VAT NO: 556 4425 31

Registered in England No: 2348038

# UL Ti MATE

## 80-55W Xenon- INSTALL

- **UL Ti MATE 80 Installation (Maximum hull thickness 65mm) and Operation instructions.**
- Qualified/Approved personnel must be used to carry out installation
- Before cutting a hole in the hull, check the hull wall thickness is not greater than 65mm. The location of the holes must be below the waterline. After cutting and finishing the hole surface, check the 61mm diameter. UL Ti MATE 80 'body' (9) can be inserted.
- Note for cored hulls - After cutting, the exposed surfaces of the hole must be finished to form a solid surface through it. Thus protecting the internal core of the hull. The wall thickness of the hole should not be less than 5mm-0.25inch. Apply 3M-4200FC sealant to the 'body' (9) flange. Slide the body into the hole and from inside the hull put the 'compensating ring' (10) on and screw the 'case securing ring' (11) up hand tight. Gently tighten the adjustment screws (6) so the compensating ring is flush to the hull and the sealant has flowed completely around the flange and hull. Do **NOT** overtighten the bolts as this will squeeze the sealant from the surfaces. Allow the sealant to solidify and remove surplus. Finally tighten the bolts to 4Nm. / 3ft. lbs.
- **Note: Maximum ambient operating temperature is 55C/131F of the ballast**
- The ballast must be installed a minimum of **24 inches (600 mm)** above the bilge. Fit the 'lamp' (5) and assemble the remaining parts to the 'through-hull' submersible marine light. Lightly grease the 'O' rings. When fitting a new lamp make sure the lamp is switched off and bring the ignitor, lamp and reflector tube away and above the bilge to the highest point before changing the lamp.
- **Cautionary Label-"Caution: do not operate lights unless totally submerged" must be located by the main switch.**
- **EARTHING LIGHT FOR CATHODIC PROTECTION-tighten the earth screw on the securing ring so that it bites into the screwed barrel. Check there is continuity to the front face. This prevents galvanic corrosion.**
- After completing the installation procedure it is highly recommended to coat the face of the 'through-hull' submersible marine light with antifouling and bond them to the anodes or a cathodic protection system.
- **Power supply**  
The 12 volt D.C ballast can operate between 11-13.5 volts. Start up current is 8 amps and 6.4 amps continuous.  
The 24 volt D.C ballast can operate between 21-26 volts. Start up current is 4.5 amps and 2.5 amps continuous.
- **Note** a maximum of two lamps can be connected to one cable supply. The correct size cable must be used and the maximum volt drop (1.5 volts) on the cable length should be calculated using the maximum start up current.

Part Description	Part No
1: Ballast 12 vdc 55 watt	95304
1: Ballast 24 vdc 55 watt	95305
2. Igniter	95306
3.'O' Ring (40mm)	02007
4.'O' Ring (50mm)	02008
5: Xenon lamp 55 watt	91012
6: Adjustment screws	93335
7: Gasket	02009
8: Lens	02010
9: UL Ti MATE 80 Body	S02652
10: Compensating ring	02602
11: Securing ring	02603-B
12: Reflector with tube	S02605
13: Lamp holder securing ring	02608-A

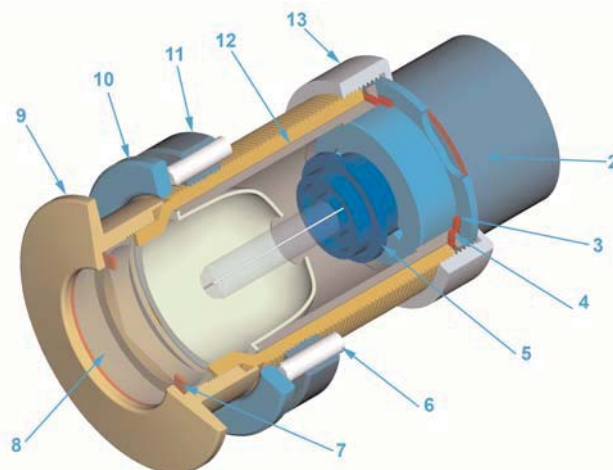

BALLAST PLUG POSITION

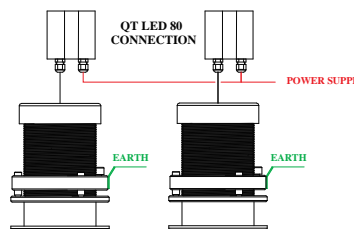

EARTH TAB AND SCREW



# QtLED & UL Ti MATE

## BONDING TEST FOR QT-LED AND UL Ti MATE 80 & 130 LIGHTS

DURING OUR PRODUCTION A RIVET IS USED TO MAKE THE ELECTRICAL CONNECTION BETWEEN THE BARREL AND FRONT FACE TO ENSURE THAT THE FRONT FACE IS BONDED BY THE BONDING SCREW TO THE VESSEL CATHODIC PROTECTION SYSTEM



WHEN THE LIGHT IS INSTALLED A TEST CAN BE MADE TO ENSURE ALL IS CORRECT. REMOVE A SMALL AREA OF THE ANODISING AS SHOWN TO EXPOSE THE ALUMINIUM

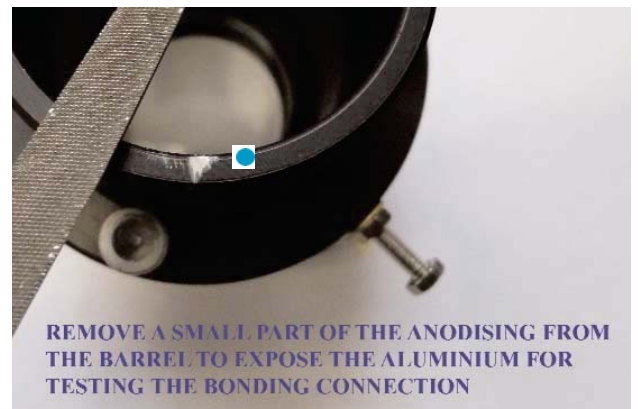

WHEN THE BONDING SCREW HAS BEEN TIGHTENED SUFFICIENTLY TO BREAK THROUGH THE ANODISING ON THE BARREL A METER IS USED TO MEASURE THE RESISTANCE. THE RESISTANCE SHOULD BE ZERO OHMS. IF IT DOES NOT THEN TIGHTEN THE BONDING SCREW FURTHER UNTIL THERE IS ZERO RESISTANCE MEASURED



INSTALLATION PICTURE SHOWING BONDING TERMINAL AND ANODE CONNECTION

