

NOVA

45:1

60:1

Airless pneumatique
pump

This manual is to be considered as an English language translation of the original manual in Italian. The manufacturer shall bear no responsibility for any damages or inconveniences that may arise due to the incorrect translation of the instructions contained within the original manual in Italian.

Due to a constant product improvement programme, the factory reserves the right to modify technical details mentioned in this manual without prior notice.



NOVA 45:1 60:1

Airless pneumatique pump

INDEX

A	WARNINGS	2
B	WORKING PRINCIPLE	3
C	TECHNICAL DATA	3
D	DESCRIPTION OF THE EQUIPMENT	5
E	TRANSPORT AND UNPACKING	6
F	SAFETY RULES.....	6
G	CONDITIONS OF GUARANTEE	6
H	TYPICAL INSTALLATION.....	8
I	SETTING UP.....	8
J	OPERATION.....	8
K	CLEANING AT THE END OF THE WORK	9
L	ROUTINE MAINTENANCE	9
M	PROBLEMS AND SOLUTIONS	10
N	DISASSEMBLY OF THE PNEUMATIC MOTOR.....	11
O	DISASSEMBLY OF THE PUMPING GROUP	16
P	EXPLODED VIEW FOR MOTOR GROUP	20
Q	EXPLODED VIEW FOR STAINLESS STEEL PUMPING GROUP	22
R	EXPLODED VIEW FOR CARBON STEEL PUMPING GROUP	24
S	EXPLODED VIEW FOR HIGH PRESSURE LINE FILTER	26
T	COMPLETE HANDTRUCK	28
U	AIR GROUP COMPLETE	29
V	ACCESSORIES.....	30
W	DESCRIPTION FOR EXPLOSIVE AREAS	34
	DECLARATION OF CONFORMITY	37

**WE ADVISE THE USE OF THIS EQUIPMENT ONLY BY PROFESSIONAL OPERATORS.
ONLY USE THIS MACHINE FOR USAGE SPECIFICALLY MENTIONED IN THIS MANUAL.**

Thank you for choosing a **LARIUS S.R.L.** product.
As well as the product purchased, you will receive a range of support services
enabling you to achieve the results desired, quickly and professionally.



A WARNINGS

The table below provides the meaning of the symbols used in this manual in relation to using, earthing, operating, maintaining, and repairing of this equipment.

	<ul style="list-style-type: none"> • Read this operator's manual carefully before using the equipment. • An improper use of this machine can cause injuries to people or things. • Do not use this machine when under the influence of drugs or alcohol. • Do not modify the equipment under any circumstances. • Use products and solvents that are compatible with the various parts of the equipment, and read the manufacturer's warnings carefully. • See the Technical Details for the equipment given in the Manual. • Check the equipment for worn parts once a day. If any worn parts are found, replace them using ONLY original spare parts. • Keep children and animals away from work area. • Comply with all safety standards.
	<ul style="list-style-type: none"> • It indicates an accident risk or serious damage to equipment if this warning is not followed.
	<p>FIRE AND EXPLOSION HAZARD</p> <ul style="list-style-type: none"> • Solvent and paint fumes in work area can ignite or explode. • To help prevent fire and explosion: <ul style="list-style-type: none"> - Use equipment ONLY in well ventilated area. - Eliminate all ignition sources, such as pilot lights, cigarettes and plastic drop cloths (potential static arc). - Ground equipment and conductive objects. - Use only grounded hoses. - Do not use trichloroethane, methylene chloride, other halogenated hydrocarbon solvents or fluids containing such solvents in pressurized aluminium equipment. Such use can cause serious chemical reaction and equipment rupture, and result in death, serious injury, and property damage. - Do not form connections or switch light switches on or off if the air contains inflammable fumes. • If electrical shocks or discharges are encountered the operation being carried out using the equipment must be stopped immediately. • Keep a fire extinguisher at hand in the immediate vicinity of the work area.
	<ul style="list-style-type: none"> • It indicates wound and finger squashing risk due to movable parts in the equipment. • Tenersi lontano dalle parti in movimento. • Do not use the equipment without the proper protection. • Before any inspection or maintenance of the equipment, carry out the decompression procedure explained in this manual, and prevent any risk of the equipment starting unexpectedly.
	<ul style="list-style-type: none"> • Report any risk of chemical reaction or explosion if this warning has not been given. • (IF PROVIDED) There is a risk of injury or serious lesion related to contact with the jet from the spray gun. If this should occur, IMMEDIATELY contact a doctor, indicating the type of product injected. • (IF PROVIDED) Do not spray before the guard has been placed over the nozzle and the trigger on the spray gun. • (IF PROVIDED) Do not put your fingers in the spray gun nozzle. • Once work has been completed, before carrying out any maintenance, complete the decompression procedure.
	<ul style="list-style-type: none"> • It indicates important recommendations about disposal and recycling process of products in accordance with the environmental regulations.
	<ul style="list-style-type: none"> • Mark any clamps attached to earth cables. • Use ONLY 3-wire extension cords and grounded electrical outlets. • Before starting work make sure that the electrical system is grounded and that it complies with safety standards. • High-pressure fluid from gun, hose leaks, or ruptured components will pierce skin. • To help prevent injection, always: <ul style="list-style-type: none"> - (IF PROVIDED) Engage trigger lock when not spraying. - (IF PROVIDED) Do not put your hand over the spray tip. Do not stop or deflect leaks with your hand, body or other. - (IF PROVIDED) Do not point gun at anyone or at any part of the body. - (IF PROVIDED) Never spray without tip guard. - Do pressure relief if you stop spraying or being servicing sprayer and before any maintenance operations. - Do not use components rated less than sprayer Maximum Working Pressure. - Never allow children to use this unit - (IF PROVIDED) Brace yourself; gun may recoil when triggered. • If high pressure fluid pierces your skin, the injury might look like "just a cut", but it is a serious wound! Get immediate medical attention.
	<ul style="list-style-type: none"> • It is obligatory to wear suitable clothing as gloves, goggles and face shield. • Wear clothing that complies with the safety standards in force in the country in which the equipment is used. • Do not wear bracelets, earrings, rings, chains, or anything else that may hinder the operator's work. • Do not wear clothing with wide sleeves, scarves, ties, or any other piece of clothing that could get tangled up in moving parts of the equipment during the work, inspection, or maintenance cycles.



B WORKING PRINCIPLE

NOVA pump 45:1 (or 60:1) is a pneumatic pump to be used in the high pressure painting without air (*Airless*) or for transferring of fluids in case of more stations of usage.

NOVA pump is essentially constituted of an air motor and a structure called «material pumping group» or simply «pumping group».

In the pneumatic motor, compressed air causes the vertical reciprocating movement of the motor piston; this movement

is transmitted through a connecting rod to the material pumping piston.

So doing the pump sucks the fluid and pushes it to the outlet. The ratio 45:1 (o 60:1) means that the outlet pressure of fluid is 45 (o 60) times higher than the pump feed air pressure.

C TECHNICAL DATA

	NOVA 45:1	NOVA 60:1
PUMP FEED AIR PRESSURE	3-7 bar (40-90 psi)	3-7 bar (40-90 psi)
MAXIMUM PRESSURE OF THE PRODUCT	270 bar (3900 psi)	360 bar (5200 psi)
FEED AIR INLET	3/4" GAS (M)	3/4" GAS (M)
MAXIMUM DELIVERY	14 l/min (3,7 gpm)	12 l/min (3,2 gpm)
CYCLES PER LITRE	4	5
MAXIMUM CYCLES PER MINUTE	60	60
MATERIAL OUTLET	1" conical GAS (F)	1" conical GAS (F)
WEIGHT	57 kg	57 kg
NOISE PRESSURE LEVEL	<90 dB (A)	<90 dB (A)
TOTAL HEIGHT	1110 mm	1110 mm

Parts of the pump in contact with the material

Pumping group: galvanized carbon steel and cast iron or stainless steel AISI 303 and 420B

Sealing balls: stainless steel AISI 420B

Gaskets: PTFE or nitrile or delrin or vulkollan



Always observe these instructions carefully when evaluating the product compatibility and in case of disposal of some parts of the pump no more usable, in order to meet the environmental regulations on recycling process.

Other parts of the pump

Support and cylinder for pneumatic motor: aluminium

Covering: sheet FE37

Motor piston and roller pushing mount: cast iron

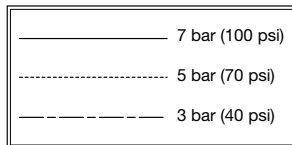
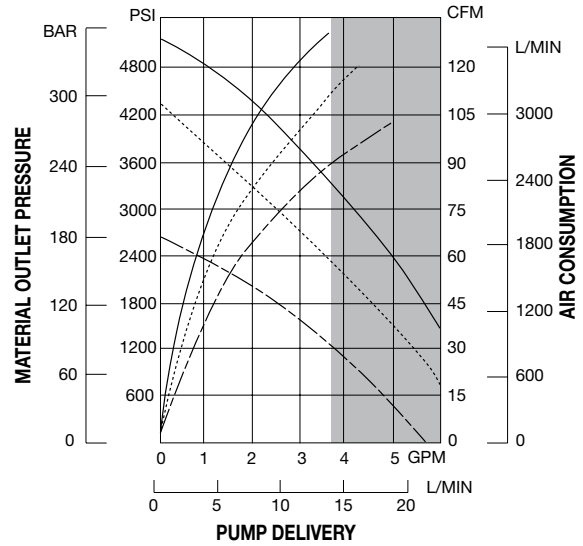
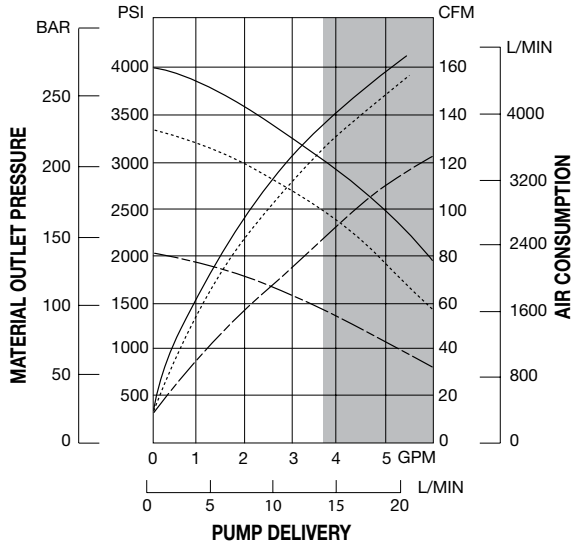
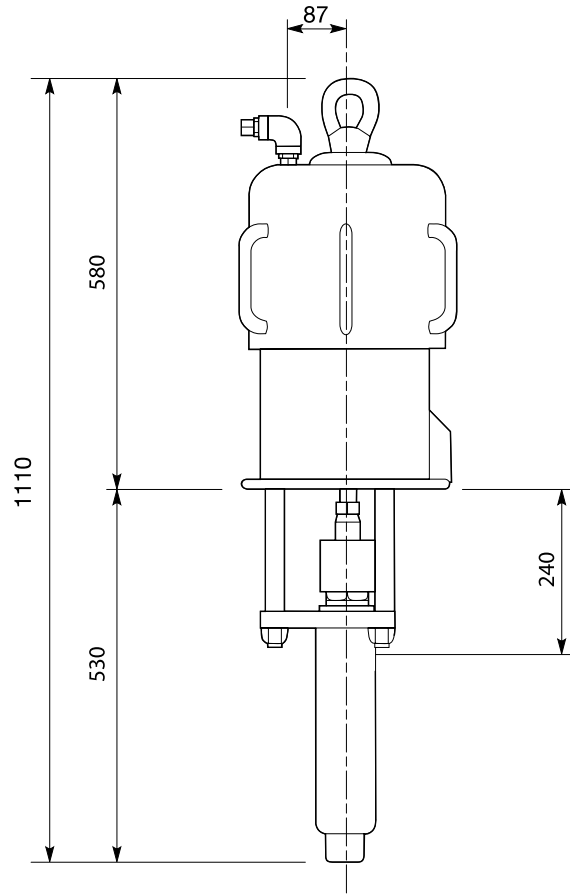

Black curve: Material outlet pressure
Gery curve: Air consumption

The pump can work in continuity when the delivery is limited to the white zone. Out of this zone the speed must be intermittent.



D DESCRIPTION OF THE EQUIPMENT

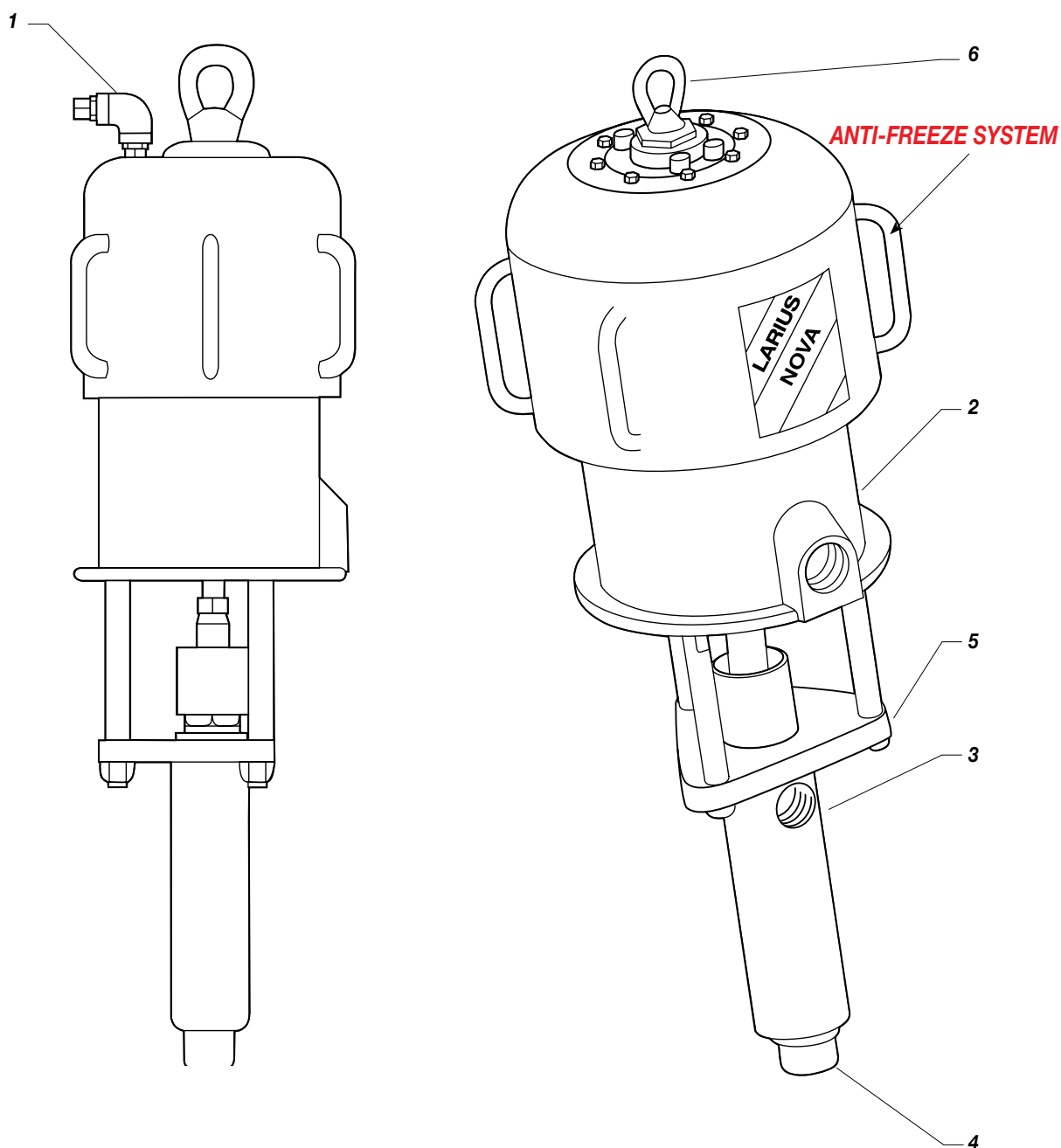

POS.	Description
1	Pump feed air inlet
2	Pneumatic motor
3	Material outlet

POS.	Description
4	Fluid inlet
5	Fluid pumping group
6	Eyebolt for pump transport



E TRANSPORT AND UNPACKING

- The packed parts should be handled as indicated in the symbols and markings on the outside of the packing.
- Before installing the equipment, ensure that the area to be used is large enough for such purposes, is properly lit and has a clean, smooth floor surface.
- The user is responsible for the operations of unloading and handling and should use the maximum care so as not to damage the individual parts or injure anyone. To perform the unloading operation, use only qualified and trained personnel (*truck and crane operators, etc.*) and also suitable hoisting equipment for the weight of the installation or its parts. Follow carefully all the safety rules. The personnel must be equipped with the necessary safety clothing.
- The manufacturer will not be responsible for the unloading operations and transport to the workplace of the machine.
- Check the packing is undamaged on receipt of the equipment. Unpack the machine and verify if there has been any damage due to transportation. In case of damage, call immediately LARIUS and the Shipping Agent. All the notices about possible damage or anomalies must arrive timely within 8 days at least from the date of receipt of the plant through Registered Letter to the Shipping Agent and to LARIUS.
- The disposal of packaging materials is a customer's competence and must be performed in accordance with the regulations in force in the country where the plant is installed and used. It is nevertheless sound practice to recycle packaging materials in an environment-friendly manner as much as possible.

F CONDITIONS OF GUARANTEE



The conditions of guarantee do not apply in the following situations:

- improper washing and cleaning of components causing malfunction, wear or damage to the equipment or any of its parts;
- improper use of the equipment;
- use that does not conform with applicable national legislation;
- incorrect or faulty installation;
- modifications, interventions and maintenance that have not been authorised by the manufacturer;
- use of non-original spare parts or parts that do not correspond to the specific model;
- total or partial non-compliance with the instructions provided.

G SAFETY RULES

- THE EMPLOYER SHALL TRAIN ITS EMPLOYEES ABOUT ALL THOSE RISKS STEMMING FROM ACCIDENTS, ABOUT THE USE OF SAFETY DEVICES FOR THEIR OWN SAFETY AND ABOUT THE GENERAL RULES FOR ACCIDENT PREVENTION IN COMPLIANCE WITH INTERNATIONAL REGULATIONS AND WITH THE LAWS OF THE COUNTRY WHERE THE PLANT IS USED.

THE BEHAVIOUR OF THE EMPLOYEES SHALL STRICTLY COMPLY WITH THE ACCIDENT PREVENTION AND ALSO ENVIRONMENTAL REGULATIONS IN FORCE IN THE COUNTRY WHERE THE PLANT IS INSTALLED AND USED.



Read carefully and entirely the following instructions before using the product. Please save these instructions in a safe place.



The unauthorised tampering/replacement of one or more parts composing the machine, the use of accessories, tools, expendable materials other than those recommended by the Manufacturer can be a danger of accident.

The Manufacturer will be relieved from tort and criminal liability.

- KEEP YOUR WORK PLACE CLEAN AND TIDY. DISORDER WHERE YOU ARE WORKING CREATES A POTENTIAL RISK OF ACCIDENTS.
- ALWAYS KEEP PROPER BALANCE AVOIDING UNUSUAL STANCE.
- BEFORE USING THE TOOL, ENSURE THERE ARE NOT DAMAGED PARTS AND THE MACHINE CAN WORK PROPERLY.
- ALWAYS FOLLOW THE INSTRUCTIONS ABOUT SAFETY AND THE REGULATIONS IN FORCE.
- KEEP THOSE WHO ARE NOT RESPONSIBLE FOR THE EQUIPMENT OUT OF THE WORK AREA.
- NEVER EXCEED THE MAXIMUM WORKING PRESSURE INDICATED.
- NEVER POINT THE SPRAY GUN AT YOURSELVES OR AT OTHER PEOPLE. THE CONTACT WITH THE CASTING CAN CAUSE SERIOUS INJURIES.
- IN CASE OF INJURIES CAUSED BY THE GUN CASTING, SEEK IMMEDIATE MEDICAL ADVICE SPECIFYING THE TYPE OF THE PRODUCT INJECTED. NEVER UNDERVALUE A WOUND CAUSED BY THE INJECTION OF A FLUID.



- ALWAYS DISCONNECT THE SUPPLY AND RELEASE THE PRESSURE IN THE CIRCUIT BEFORE PERFORMING ANY CHECK OR PART REPLACEMENT OF THE EQUIPMENT.
- NEVER MODIFY ANY PART IN THE EQUIPMENT. CHECK REGULARLY THE COMPONENTS OF THE SYSTEM. REPLACE THE PARTS DAMAGED OR WORN. CONNECTION BETWEEN PUMP, FLEXIBLE HOSE AND SPRAY GUN BEFORE USING THE EQUIPMENT.
- ALWAYS USE THE FLEXIBLE HOSE SUPPLIED WITH STANDARD KIT. THE USE OF ANY ACCESSORIES OR TOOLING OTHER THAN THOSE RECOMMENDED IN THIS MANUAL, MAY CAUSE DAMAGE OR INJURE THE OPERATOR.
- THE FLUID CONTAINED IN THE FLEXIBLE HOSE CAN BE VERY DANGEROUS. HANDLE THE FLEXIBLE HOSE CAREFULLY. DO NOT PULL THE FLEXIBLE HOSE TO MOVE THE EQUIPMENT. NEVER USE A DAMAGED OR A REPAIRED FLEXIBLE HOSE.



The high speed of travel of the product in the hose can create static electricity through discharges and sparks. It is suggested to earth the equipment.

The pump is earthed through the earth cable of the supply. The gun is earthed through the high pressure flexible hose.

All the conductors near the work area must be earthed.

- NEVER SPRAY OVER FLAMMABLE PRODUCTS OR SOLVENTS IN CLOSED PLACES.
- NEVER USE THE TOOLING IN PRESENCE OF POTENTIALLY EXPLOSIVE GAS.



Always check the product is compatible with the materials composing the equipment (*pump, spray gun, flexible hose and accessories*) with which it can come into contact. Never use paints or solvents containing Halogen Hydrocarbons (*as the Methylene Chloride*).

If these products come into contact with aluminium parts can provoke dangerous chemical reactions with risk of corrosion and explosion.



Avoid approaching too much to the pump piston rod when the pump is working or under



pressure. A sudden movement of the piston rod can cause wounds or finger squashing.

IF THE PRODUCT TO BE USED IS TOXIC, AVOID INHALATION AND CONTACT BY USING PROTECTION GLOVES, GOGGLES AND PROPER FACE SHIELDS.



TAKE PROPER SAFETY MEASURES FOR THE PROTECTION OF HEARING IN CASE OF WORK NEAR THE PLANT.



The machine is equipped with an anti-freeze system that allows it to work even at very low temperatures. However, after a few minutes of operation, the upper metal outer surface cools dramatically.

Avoid touching the area indicated.

Contact of the skin with the low-temperature area may cause frostbite. Common working clothes and leather gloves provide adequate protection.

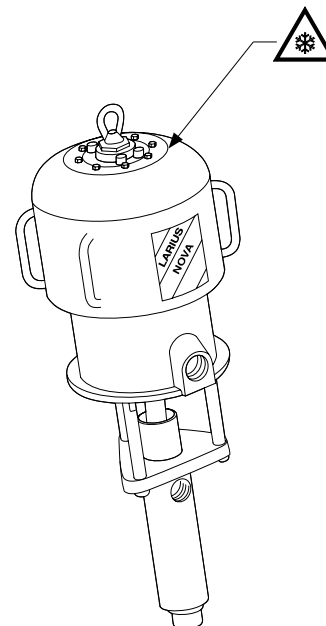



H TYPICAL INSTALLATION

The NOVA pump is generally supplied on support for wall fastening or on trolley or on double post ram.

For the correct fastening of the pump on other structures use the 4 holes placed at the base of the pneumatic motor (see the illustration for dimensions).

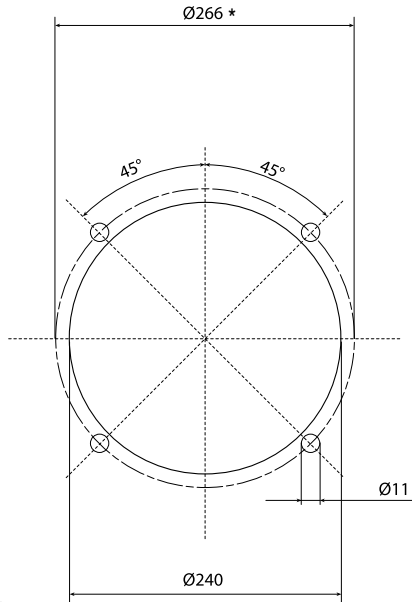

*Int. holes

I SETTING-UP

PUMP FASTENING ON THE HOIST

For the correct fastening of the pump on the ram, follow the procedure described in the manual for use and maintenance of the double post ram.

CONNECTION TO THE FEED AIR

For pump feed use a hose with an internal diameter no lower than 20 mm.



Install at the pump inlet an air pressure regulator (it is suggested complete with condensate filter and lubricator). The outlet pressure of the material is 45 times (NOVA 45:1) or 60 times (NOVA 60:1) the inlet pressure of the pump feed air. Therefore, it is extremely important to adjust the value of the feed air pressure.

CONNECTION OF THE MATERIAL OUTLET HOSE

Connect the high pressure hose at the outlet of the pump. It is recommended to tighten the fittings.

J WORKING



Check all the fittings for connection of the different components (pump, flexible hose, spray gun, etc.) before using the equipment.

- Dip the material pumping hose (H1) into the product tank (H2) (if the pump is fixed on the double post ram, follow the procedure described in the manual of use and maintenance of the double post ram).

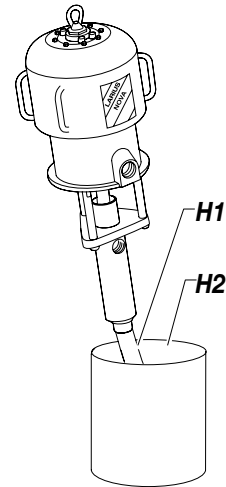

- Make the compressed air flow into the pump. It is advisable to adjust air pressure to minimum necessary for its continuous working.
- When the product chamber is full, pump will start working and stopping. Pump will start working again any time the trigger of the spray gun is pressed or the delivery valve is open.
- The pump has been adjusted at our factory with light mineral oil and a part of it could be left inside the pumping element. Point the spray gun (H3) or the delivery valve at the tank (H4) and drain the product left inside the pump till the material to be used has come out.

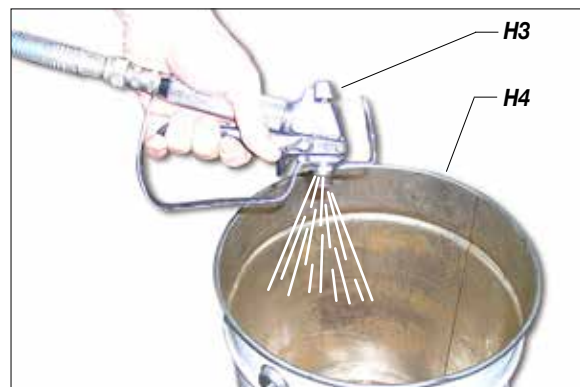

Always avoid pump idling: this operation could damage the pneumatic motor and the seals.

- In case of long inactivity during the use with the plant (for example, all night long at the end of the working day), ensure the product you are using can be left inside the pump and the different pipes without drying. In this case, it is enough to stop the air supply to the pump and drain the residual pressure in the circuit acting on the delivery valve or on the pump bleeder valve.



K CLEANING AT THE END OF THE WORK

By "cleaning at the end of the work" is meant the cleaning to carry out in case of use with a different product or if a long period of storage is foreseen.

- Stop the air supply to the pump.
- Dip the material pumping hose into the washing solvent tank (*check its chemical compatibility with the product being used*).
- Make compressed air flow into the pump. It is advisable to adjust the air pressure to minimum necessary to its continuous working.
- Point the spray gun or the delivery valve at a container and drain all the product left inside the pump till a clean solvent comes out.

- Now, stop the air supply to the pump and drain the residual pressure.
- In case of long inactivity, the operations of sucking and leaving light mineral oil inside the pumping element are suggested.



Store possible dangerous fluids in proper containers. Their disposal must be performed in accordance with the regulations in force about the industrial waste goods.

L ROUTINE MAINTENANCE



Always close the compressed air supply and release the pressure in the plant before performing any check or maintenance of the pump.

- Check periodically (*and each time the pump is operated after a long storage*) the packing nut is not loosened, causing otherwise the coming out of the product. To tighten the packing nut, lift the wet cup (*see illustration below*). Use the wrench supply (*ref. 11504*). The packing nut must be tightened so as to avoid wastes of product, but not excessively to provoke pumping piston seizure and seals wear. In case of persistent coming out of product, replace the seals.
- To prevent the product from drying up on the piston rod, refill the cup with lubricant (*compatible with the product used*).
- Check periodically the air supply to the pump. Ensure the air is always clean and lubricated. In case of installation of a lubricator on the air supply to the pump, it is advisable to keep its cup full of a mixture of water and antifreeze liquid (*dilution ratio 4:1*).

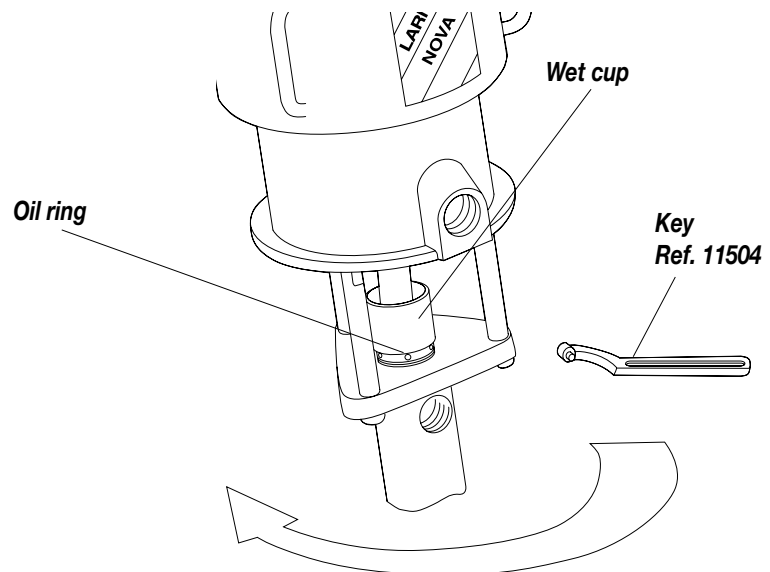



M PROBLEMS AND SOLUTIONS

Problem	Cause	Solution
<ul style="list-style-type: none"> The pump does not start 	<ul style="list-style-type: none"> Feed air not sufficient; Outlet product line clogged; Dried product inside the pumping element; Pneumatic motor blocked in the cycle reversal position; Parts failure of the pneumatic motor; 	<ul style="list-style-type: none"> Check the air supply. Widen the diameter of the feed hose; Clean. Disconnect the outlet product pipe. Feed pump at minimum pressure and check if the pump starts without the outlet pipe; Disassemble the pumping group and clean; Turn the plug counterclockwise and push downwards the valve body. Use a metal rod and a mallet; Disassemble the motor and check;
<ul style="list-style-type: none"> Accelerated working and no pressure of the pump 	<ul style="list-style-type: none"> There is no product; The pump sucks air; Feed air not sufficient; Suction valve worn or partially clogged; Outlet valve worn or partially clogged; 	<ul style="list-style-type: none"> Add product; Open the bleeder valve. For ram version, follow the instructions in the relevant manual; Increase the feed air pressure; Disassemble the suction valve. Clean and/or replace if necessary the worn parts; Disassemble the outlet valve. Clean and/or replace if necessary the worn parts;
<ul style="list-style-type: none"> The pump works, but not sufficient flow of product 	<ul style="list-style-type: none"> Suction valve worn or partially clogged; Outlet product line clogged; The feed air pressure is too low; 	<ul style="list-style-type: none"> Disassemble the suction valve. Clean and/or replace the worn parts; Clean. Disconnect the outlet product pipe. Feed pump at minimum pressure and check if delivery increases without the outlet pipe; Increase air pressure;
<ul style="list-style-type: none"> Leakage of product from the wet cup 	<ul style="list-style-type: none"> Upper gaskets worn. 	<ul style="list-style-type: none"> Tighten the packing nut. In case of persistent waste of product, replace the upper gaskets of the pumping element.



Always close the compressed air supply and release the pressure in the plant before performing any check or replacement of parts of the pump.



N DISASSEMBLY OF THE PNEUMATIC MOTOR



Always close the compressed air supply and release the pressure in the plant before disassembling the pneumatic motor of the pump.

- Unscrew the coupling sleeve so as to disconnect the pumping group from the motor.
- Disconnect the air feed pipe to the pump.
- Unscrew the fitting (N1) and the sleeve (N2).
- Turn counterclockwise the screws (N3) [take care of the washers (N4)] and remove the covering (N5).
- Unscrew the two ring nuts (N6) from the mount (N7).
- Turn counterclockwise the screws (N8) [take care of the washers (N9)] and extract the mount (N7) together with the rollers (N10) and the pins (N11).
- Extract the spring (N12), the spring guide rod (N13) and the roller pushing piston (N14). Ensure the spring slides freely on the guide rod, the guide rod slides into the roller pushing piston and this last slides into the mount hole. Replace possible damaged parts.
- Check the roller (N10) and the pin (N11) are undamaged. Replace them if damaged.
- Remove and check the rubber pad (N15) and the washer (N16).

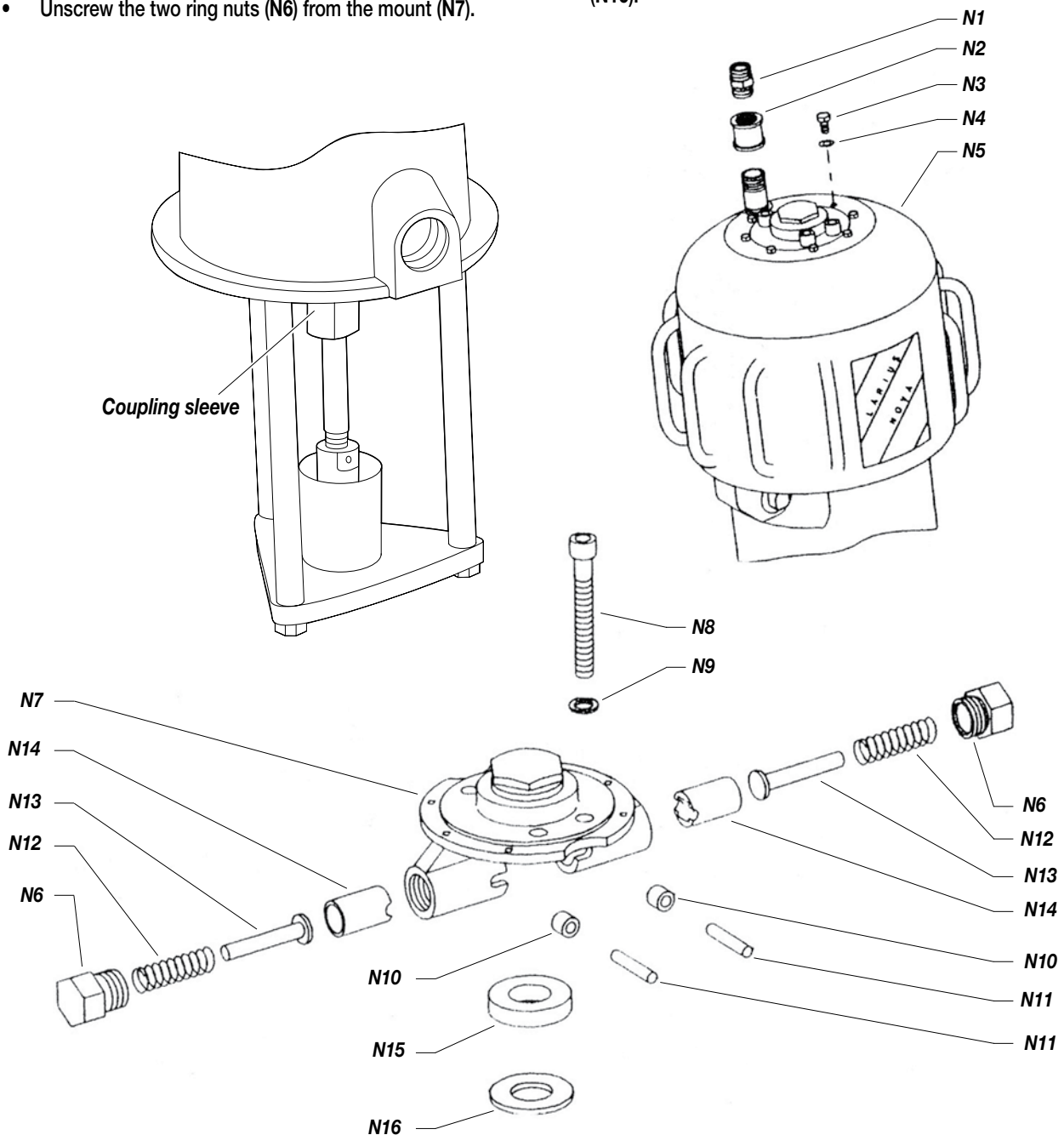



- Pull upwards the seat (N17) so as to take out the valves (N18) and the springs (N19) (clean and/or replace the worn parts).
- Unscrew the lock nut (N20) [take care of the washer (N21)] by keeping the bush (N22) blocked using a key.
- Extract the seat (N17) from the rod (N23).
- Unscrew the bush (N22) (if necessary, keep the rod (N23) blocked on the threaded part using pliers with the bits wrapped in rags to avoid damage to thread).

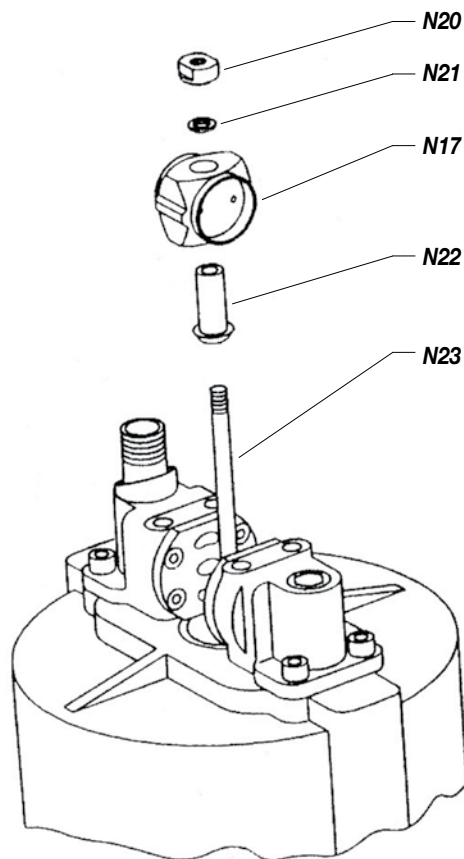
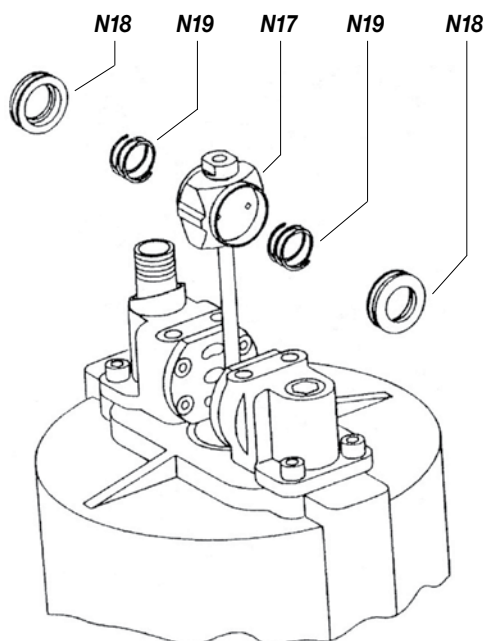

- Remove the screws (N24) [take care of the washers (N25)], a manifold (N26) and the gasket (N27).



Handle with care the manifold. The edges of its plate are very sharp.

Important: do not remove the other manifold if not necessary (it will facilitate the fastening of the manifold removed).

- Using a screwdriver, extract the washer (N28) and the rubber pad (N29).

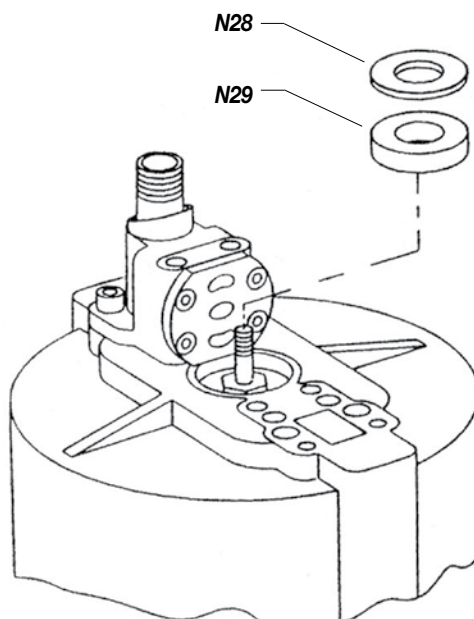
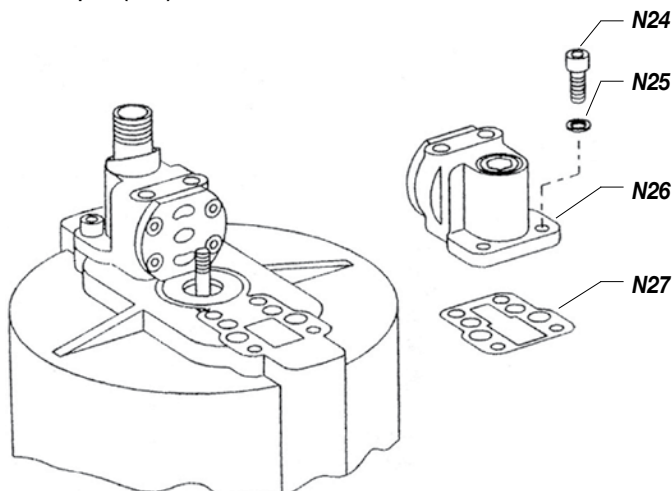



- Turn counterclockwise the trip rod bearing (N30) [take care of the washer (N31)] and check the seal inside the screw (N30) is undamaged.
- Take out the screws (N32) [take care of the washers (N33)] and remove carefully the cylinder (N34) (do not bend it during extraction in order to avoid that motor piston may damage the internal surface of the cylinder).

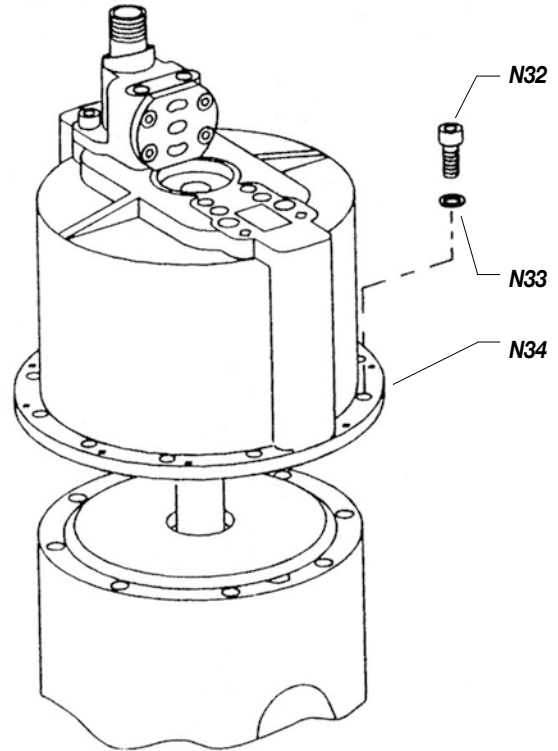
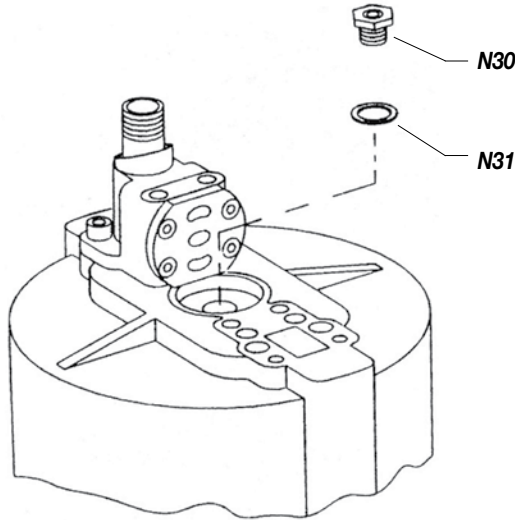

- Extract the motor piston from the motor support (N35).
- Verify the O-ring (N36) is undamaged.
- Tighten the lower edge of the piston rod using pliers (see illustration) and unscrew the fitting (N37) with a key.
- Remove the motor rod (N38) and check it is undamaged.
- Rub the motor rod (N38) with vaseline grease before inserting it into the housing of the piston rod.
- Tighten again with pliers the lower edge of the piston rod and screw the fitting (N37) (application of a sealant on the thread is advisable).

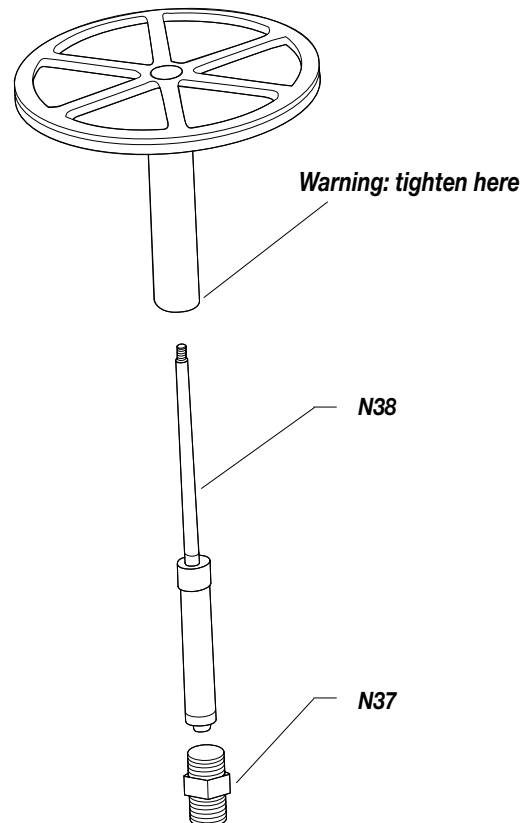
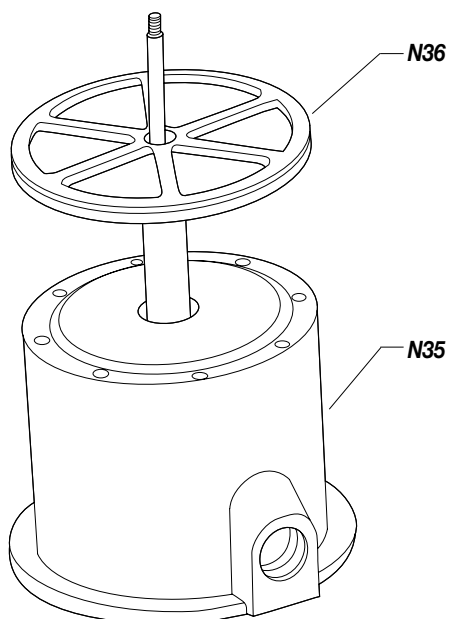



- Check the gas ring inside the support (N39) is undamaged.
- Check the gasket (N40) is undamaged and correctly positioned.
- Coat the inner walls of the cylinder (N41) with a thin layer of vaseline grease.
- Insert the motor piston (N42) into the cylinder (N41) carefully.
- Fasten the cylinder (N41) on the support (N39) (respect the position) and at the same time insert the piston rod into the support.
- Turn clockwise the screws (N43).

Check gas ring

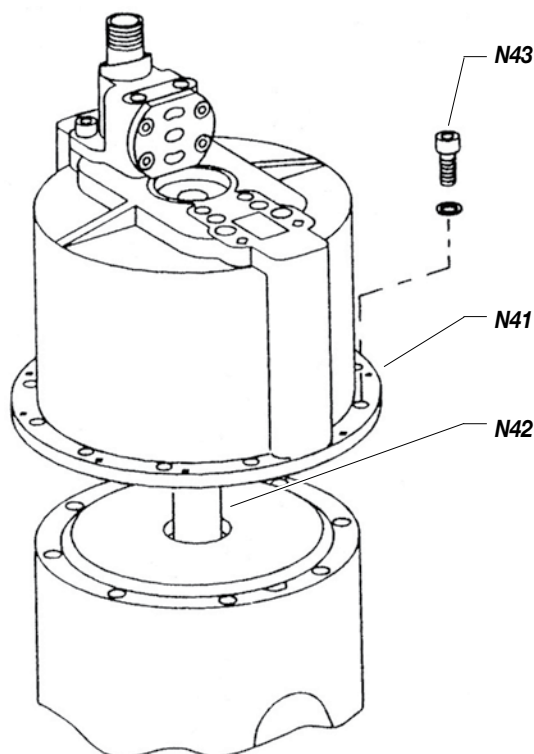
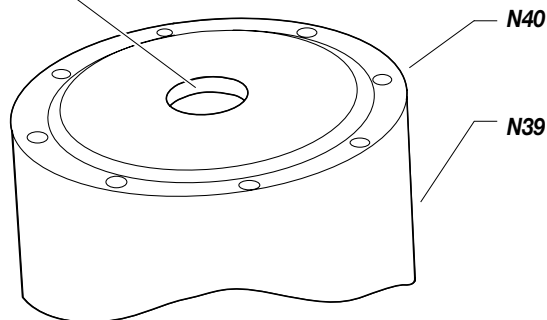

- Insert into the motor rod (N44) the washer (N45).
- Carefully insert the trip rod bearing (N46) into the motor rod (turn it slowly following the direction of the thread) and screw it on the cylinder (N41).
- Insert the rubber pad (N47) and the washer (N48) into the support.
- Screw the bush (N49) on the motor rod (N44). Insert the seat (N50), the washer (N51) and screw the lock nut (N52).



Adjust bush and lock nut so as the rod (N44) just out of about 1 mm from the lock nut (see illustration).

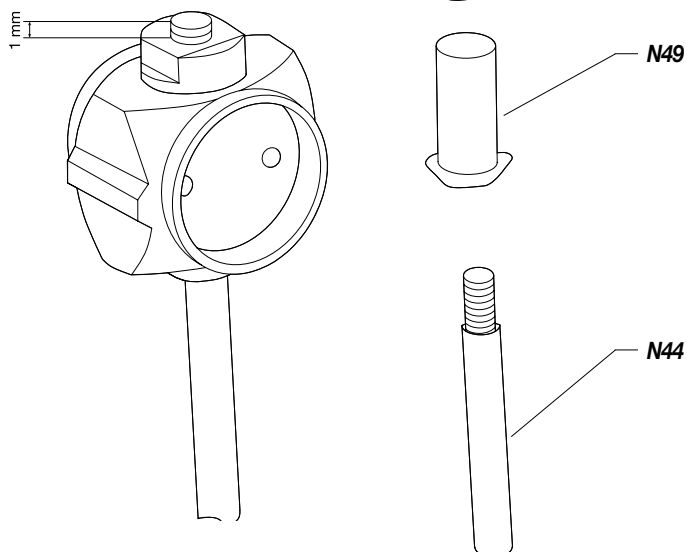
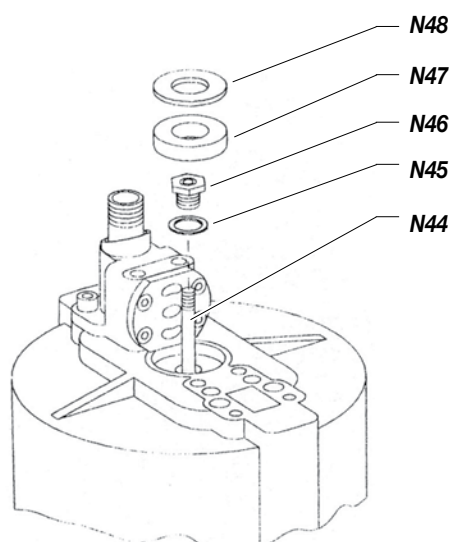



- Insert the springs (N54) and the valves (N55) into the seat (N53). Position the seat on the pump support and lay the manifold (N56) on the seat [do not forget the gasket (N57)].
- Fasten the manifold with screws (*do not tighten*) ensuring it is perfectly parallel to the other manifold and the distance between them is 46 mm (*see illustration*).

The distance between the walls of the manifold and the edge of the seat must be about 0,8 mm.

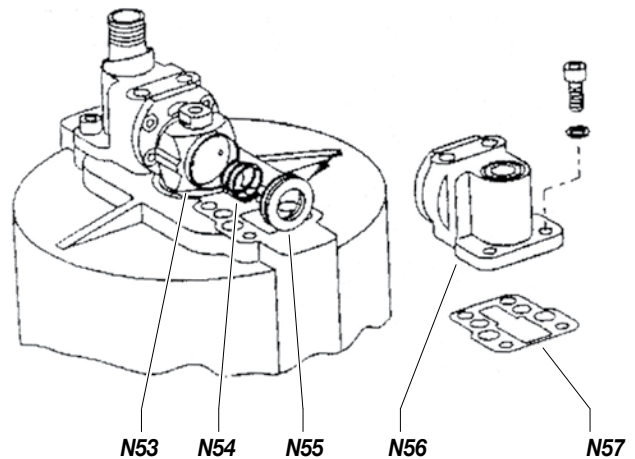
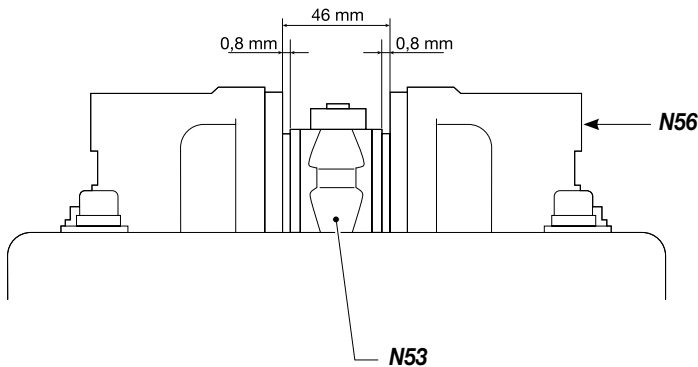

- Rub the rollers (N58) and the pins (N59) with vaseline grease and insert them into the mount (N60).
- Rub the rubber pad (N61) and the washer (N62) with vaseline grease and insert them into the mount (N60).
- Grease the roller pushing pistons (N63), the spring guide rods (N64), the springs (N65) and insert them into the mount (N60).
- Fasten without tightening the ring nuts (N66) on the mount (N60).
- Fasten the mount on the manifolds and tighten the screws (N68) [do not forget of washer (N67)].
- Tighten the ring nuts (N66) and the screws (N69).
- Assemble again the covering and all the fittings of the air supply line.

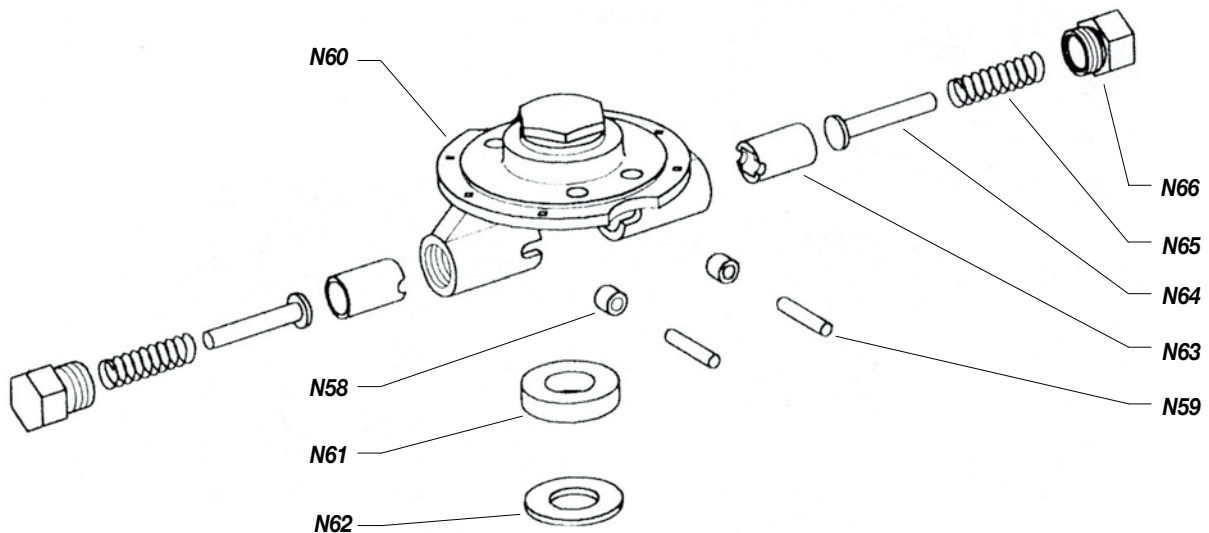
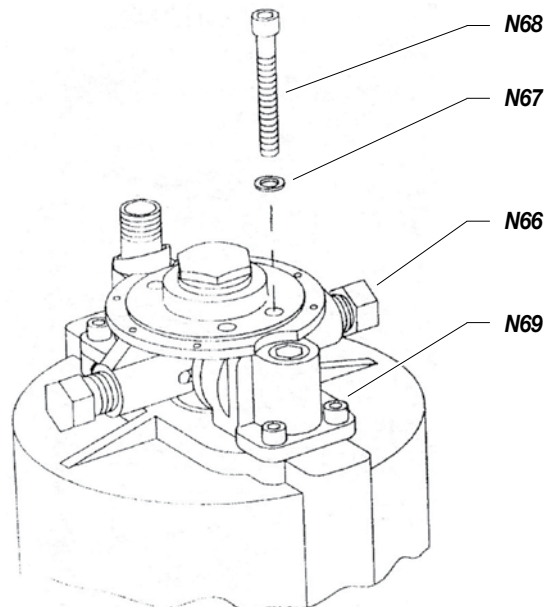



0 DISASSEMBLY OF THE PUMPING GROUP



Always close the compressed air supply and release the pressure in the plant before disassembling the pumping group. If the product being used is toxic, it is suggested to follow the cleaning procedure on page 8 to avoid the contact with the product during the disassembling of the pumping element.

- Disconnect the suction pipe and the outlet tube of the product from the pumping group.
- Unscrew the coupling sleeve so as to disconnect the pumping group from the motor.
- Remove the nuts (01) and take out the pumping group.
- Remove the wet cup (02).

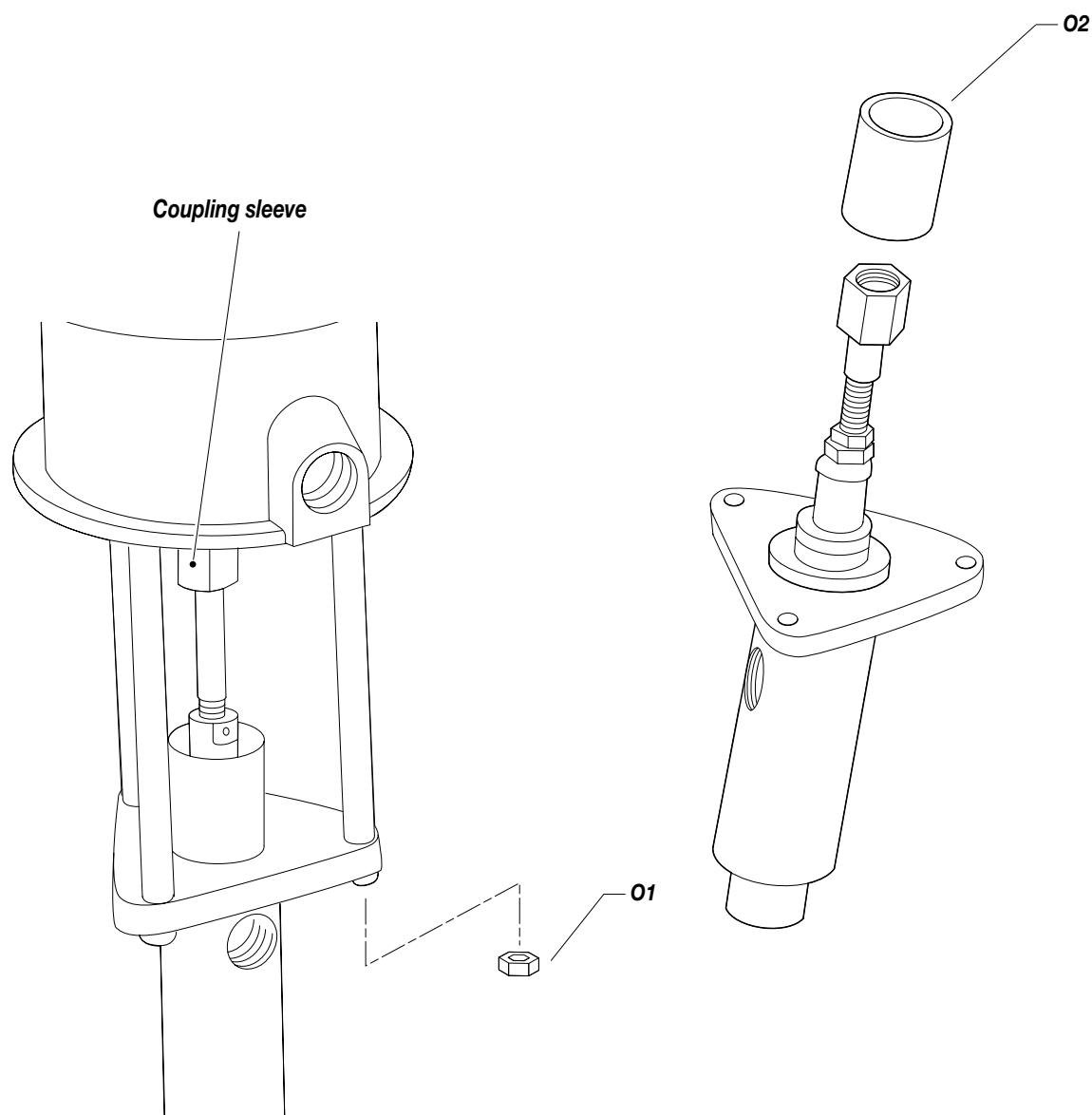



- Remove the split pin (03), loosen the nut (04) and unscrew the tie rod from the piston rod.
- Unscrew the packing nut (05).

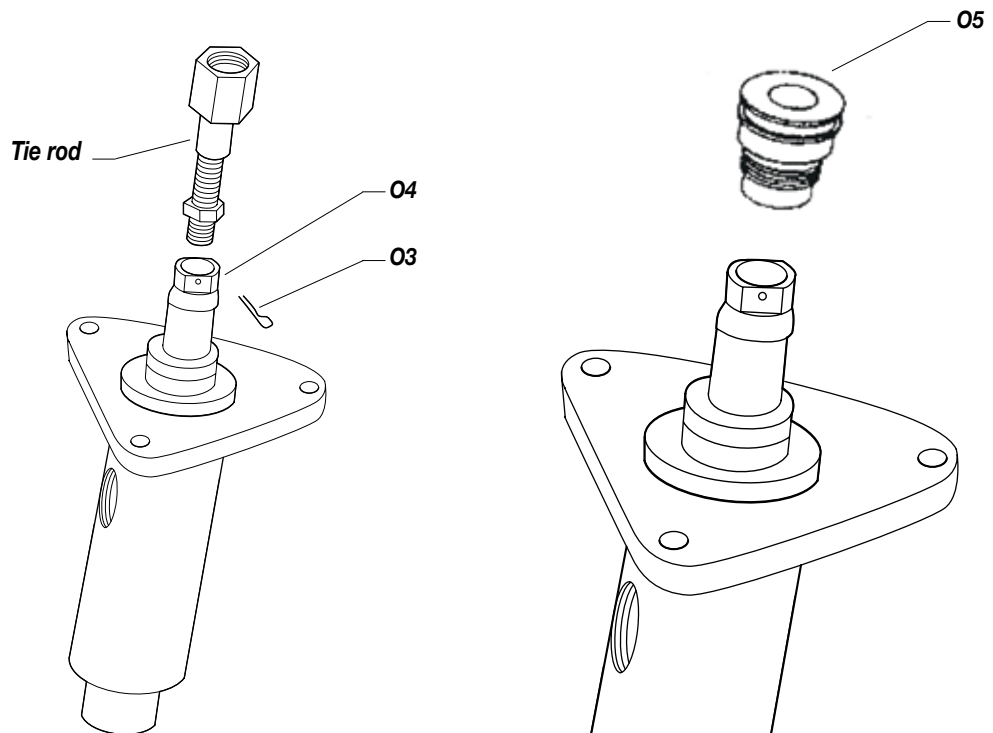

- Unscrew the suction valve. Clean and/or replace its parts, if necessary.

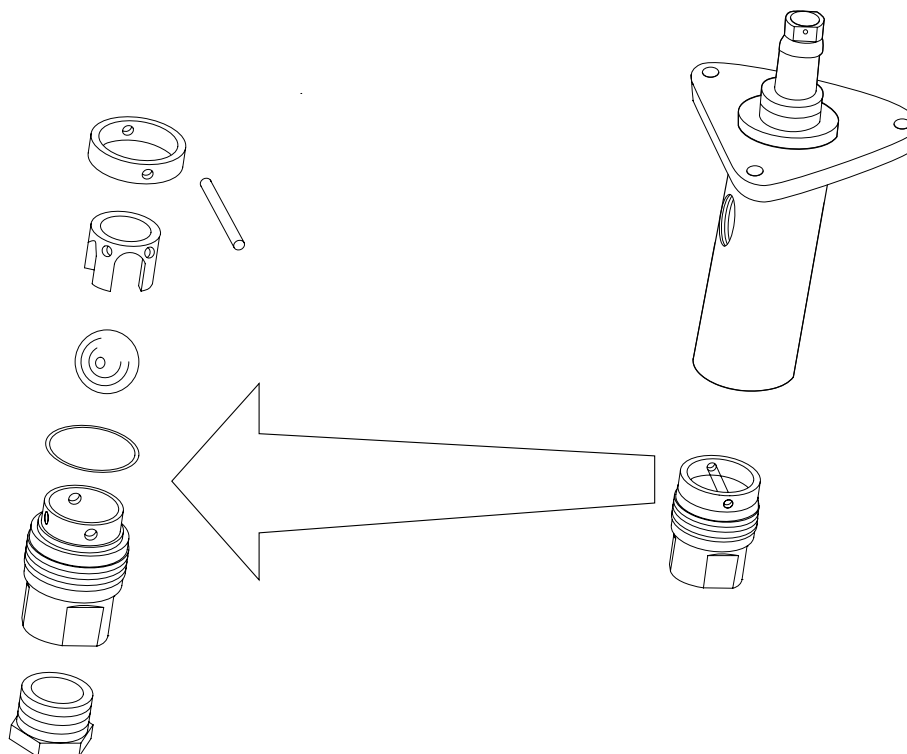



It is possible to increase the suction valve ball stroke placing the stop ball pin (O6) on the upper holes of the suction valve. This modification is suggested in case of very viscous products. The same operation can be performed on the piston rod.

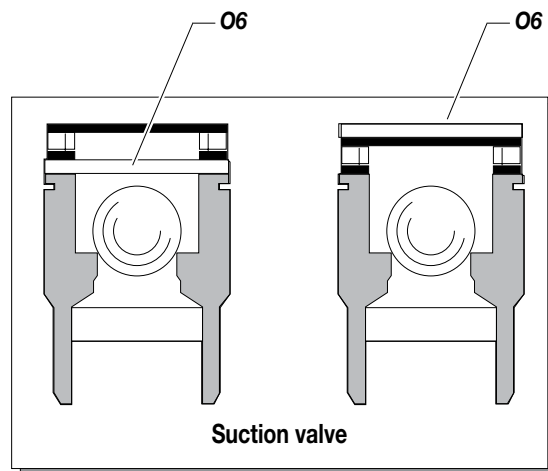

- Extract the piston rod from the bottom.
- Disassemble the piston rod and replace the gaskets worn.
- Remove the upper gaskets, if necessary, to be replaced.
- For the correct reassembling see illustration and the exploded view on page 18.

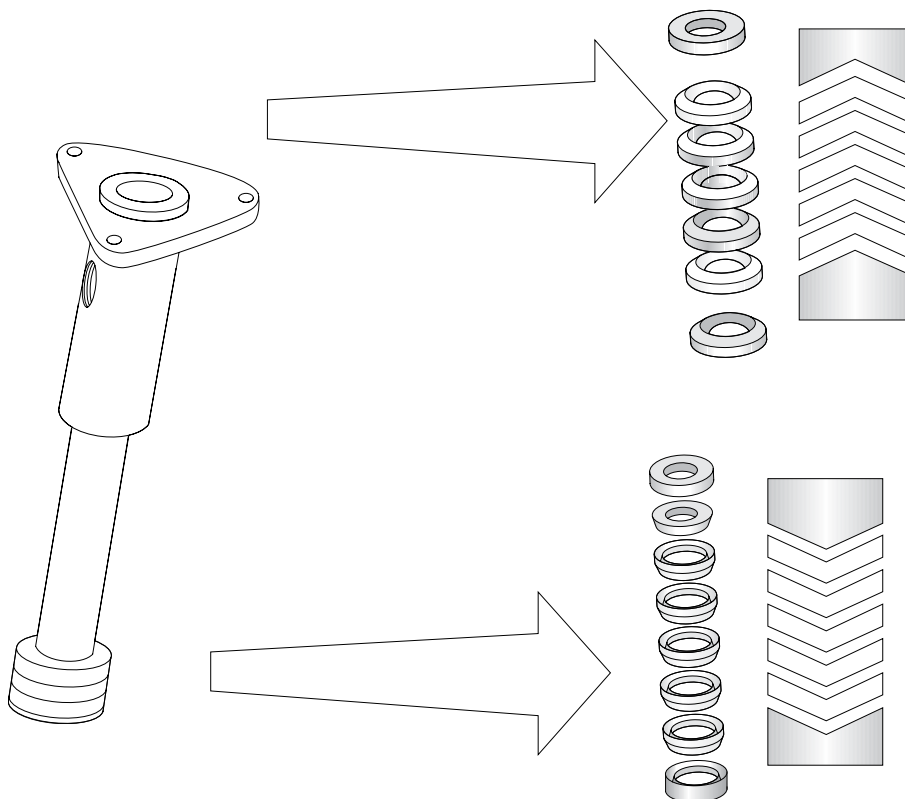

Intentionally blank page



P EXPLODED VIEW FOR MOTOR GROUP

WARNING: always indicate code and quantity for each part required.

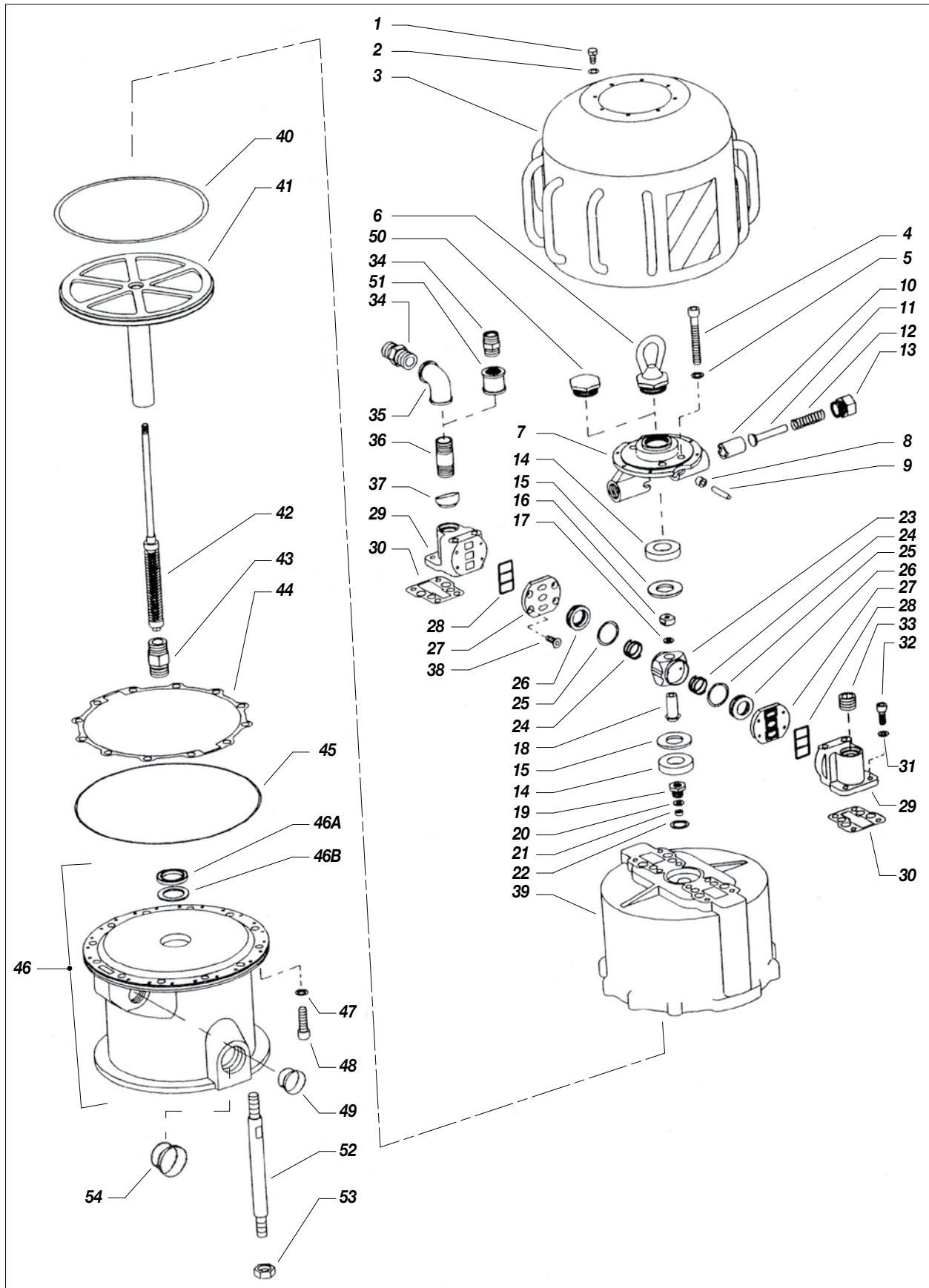



Pos.	Code	Description	Pos.	Code	Description
1	95062	Screw	29	95070	Manifold
2	95063	Washer	30	95072	Manifold gasket
3	95064	Covering	31	95096	Washer
4	95065	Screw	32	95068	Screw
5	95066	Washer	33	95067	Plug 3/4" conical GAS
6	95061	Eyebolt	34	95090	Fitting
7	95109	Support	35	95089	Elbow 3/4" GAS
8	95092	Roller	36	95088	Extension
9	95091	Pin	37	95099	Gas ring
10	95084	Roller piston	38	95074	Screw
11	95085	Spring guide	39	95100	Motor cylinder
12	95086	Spring	40	95101	O-ring
13	95087	Ring nut	41	95102	Motor piston
14	95093	Shock absorber	42	95103	Motor rod
15	95094	Washer	43	95104	Fitting
16	95095	Lock nut	44	95105	Gasket
17	95096	Washer	45	95106	O-ring
18	95098	Bush	46	95107	Complete motor mount
19	95078	Rod guide screw	46A	3314	Gas ring
20	95079	Leather ring	46B	95082	Leather ring
21	95080	Seal	47	95114	Washer
22	33031	Copper washer	48	95083	Screw
23	95097	Valve housing	49	95159	Plug
24	95077	Spring	50	510040	Plug
25	95075	O-ring	51	95944	Sleeve 3/4" GAS
26	95076	Traverse reverse valve	52	95002	Tie rod
27	95073	Manifold plate	53	95013	Nut
28	95071	Plate gasket	54	95229	Plug

**GASKETS KIT MOTOR -
CODE 40065**

Pos.	Description	Q.ty
20	Leather ring	1
21	Seal	1
22	Copper washer	1
25	O-ring	2
26	Traverse reverse valve	2
30	Manifold gasket	2
40	O-ring	1
44	Gasket	1
45	O-ring	1
46A	Gas ring	1
46B	Leather ring	1

**MOTOR MOVEMENT INVERSION DEVICE -
CODE 40066**

Pos.	Descrizione	Q.ty
8	Roller	2
9	Pin	2
10	Roller piston	2
25	O-ring	2
26	Traverse reverse valve	2
30	Manifold gasket	2



EXPLODED VIEW FOR STAINLESS STEEL PUMPING GROUP

WARNING: always indicate code and quantity for each part required.

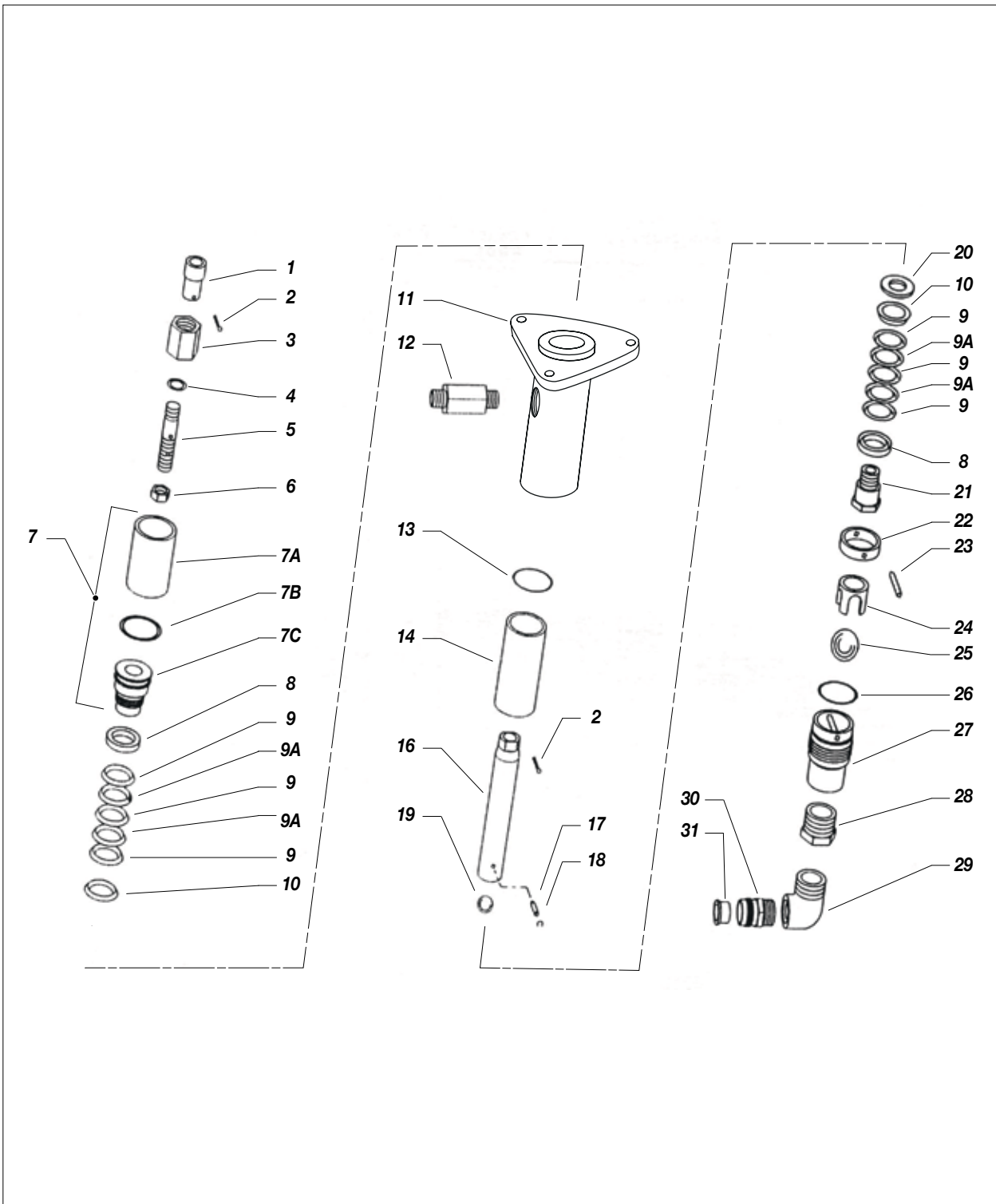

NOVA 45:1 stainless steel

Pos.	Code	Description	Pos.	Code	Description
	98200	Complete pumping group for NOVA 45:1 inox	13	95016	Gasket
1	95003	Bush	14	98217	Sleeve
2*	95015	Split pin	16	98218	Piston rod
3	95004	Sleeve	17	98220	Stop ball pin
4	95005	O-ring	18*	98219	Elastic ring
5	95006	Tie rod	19	98053	Ball Ø7/8"
6	95007	Nut	20	98222	Packing nut
7	95008	Cup complete with packing	21	98223	Piston valve
7A	95008/1	Cup	22	98224	Ring
7B	95008/3	O-ring	23	98225	Stop ball pin
7C	95008/2	Packing nut	24	98226	Ball guide
8*	98209	Female ring	25	95027	Ball Ø1-1/4"
9*	95010	PTFE "V" gasket (6 pz.)	26*	95028	O-ring
9A*	95138	Polyethylene "V" gasket (4 pz.)	27	98229	Suction valve
10*	98212	Male ring	28	98230	Reduction M-F
11	98214	Pumping group housing	29	98231	Elbow M-F
12	98126	Filter fitting	30	98232	Suction pipe fitting
			31	96099	Bush

*Pumping group repair kit for stainless steel NOVA 45:1 Ref. 40071

NOVA 60:1 stainless steel

Pos.	Code	Description	Pos.	Code	Description
	98201	Complete pumping group for NOVA 60:1 inox	13	95016	Gasket
1	95003	Bush	14	98208	Sleeve
2*	95015	Split pin	16	98202	Piston rod
3	95004	Sleeve	17	98205	Stop ball pin
4	95005	O-ring	18*	98219	Elastic ring
5	95006	Tie rod	19	98053	Ball Ø7/8"
6	95007	Nut	20	98206	Packing nut
7	95008	Cup complete with packing	21	98207	Piston valve
7A	95008/1	Cup	22	98224	Ring
7B	95008/3	O-ring	23	98225	Stop ball pin
7C	95008/2	Packing nut	24	98226	Ball guide
8*	98203	Female ring	25	95027	Ball Ø1-1/4"
9*	95504	PTFE "V" gasket (6 pz.)	26*	95028	O-ring
9A*	95514	Polyethylene "V" gasket (4 pz.)	27	98229	Suction valve
10*	98204	Male ring	28	98230	Reduction M-F
11	98210	Pumping group housing	29	98231	Elbow M-F
12	98126	Filter fitting	30	98232	Suction pipe fitting
			31	96099	Bush

*Pumping group repair kit for stainless steel NOVA 60:1 Ref. 40076



R EXPLODED VIEW FOR CARBON STEEL PUMPING GROUP

WARNING: always indicate code and quantity for each part required.

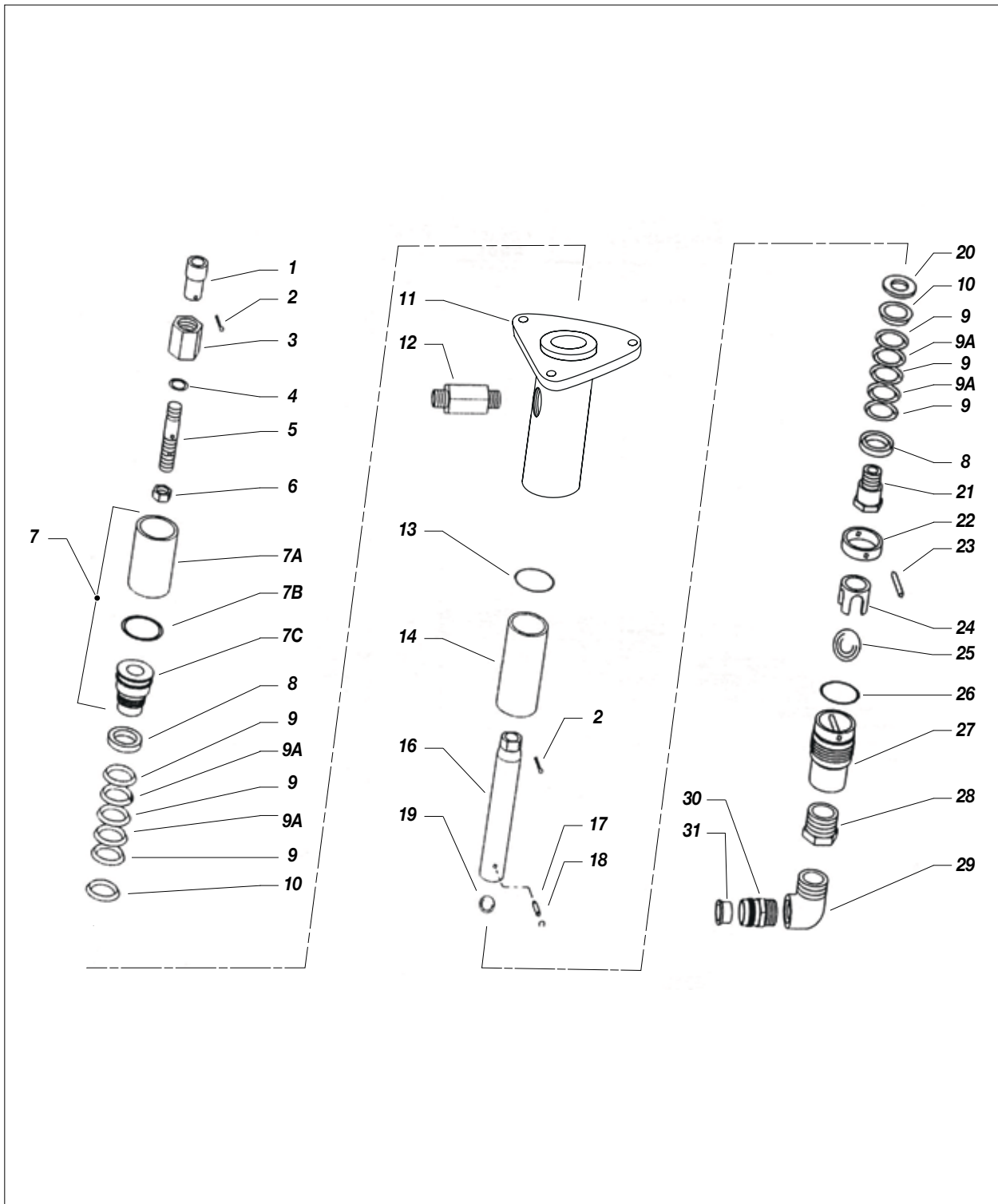

NOVA 45:1 carbon steel

Pos.	Code	Description	Pos.	Code	Description
	95001	Complete pumping group for NOVA 45:1 carbon	13	95016	Gasket
			14	95017	Sleeve
1	95003	Bush	16	95018	Piston rod
2*	95015	Split pin	17	95020	Stop ball pin
3	95004	Sleeve	18*	95019	Elastic ring
4	95005	O-ring	19	95021	Ball Ø7/8"
5	95006	Tie rod	20	95022	Packing nut
6	95007	Nut	21	95023	Piston valve
7	95008	Cup complete with packing nut	22	95024	Ring
7A	95008/1	Cup	23	95025	Stop ball pin
7B	95008/3	O-ring	24	95026	Ball guide
7C	95008/2	Packing nut	25	95027	Ball Ø1-1/4"
8*	95009	Female ring	26*	95028	O-ring
9*	95010	PTFE "V" gasket (6 pz.)	27	95029	Suction valve
9A*	95138	Polyethylene "V" gasket (4 pz.)	28	95030	Reduction M-F
10*	98212	Male ring	29	95031	Elbow M-F
11	95014	Pumping group housing	30	95032	Suction pipe fitting
12	95039	Filter fitting	31	33025	Bush

*Pumping group repair kit for carbon steel NOVA 45:1 Ref. 40070

NOVA 60:1 carbon steel

Pos.	Code	Description	Pos.	Code	Description
	95500	Complete pumping group for NOVA 60:1 carbon	13	95016	Gasket
			14	95510	Sleeve
1	95003	Bush	16	95501	Piston rod
2*	95015	Split pin	17	95507	Stop ball pin
3	95004	Sleeve	18*	95019	Elastic ring
4	95005	O-ring	19	95021	Ball Ø7/8"
5	95006	Tie rod	20	95508	Packing nut
6	95007	Nut	21	95509	Piston valve
7	95502	Cup complete with packing nut	22	95024	Ring
7A	95008/1	Cup	23	95025	Stop ball pin
7B	95008/3	O-ring	24	95026	Ball guide
7C	95008/2	Packing nut	25	95027	Ball Ø1-1/4"
8*	95503	Female ring	26*	95028	O-ring
9*	95504	PTFE "V" gasket (6 pz.)	27	95029	Suction valve
9A*	95514	Polyethylene "V" gasket (4 pz.)	28	95030	Reduction M-F
10*	95506	Male ring	29	95031	Elbow M-F
11	95511	Pumping group housing	30	95032	Suction pipe fitting
12	95039	Filter fitting	31	33025	Bush

*Pumping group repair kit for carbon steel NOVA 60:1 Ref. 40075



S EXPLODED VIEW FOR HIGH PRESSURE FILTER

WARNING: always indicate code and quantity for each part required.

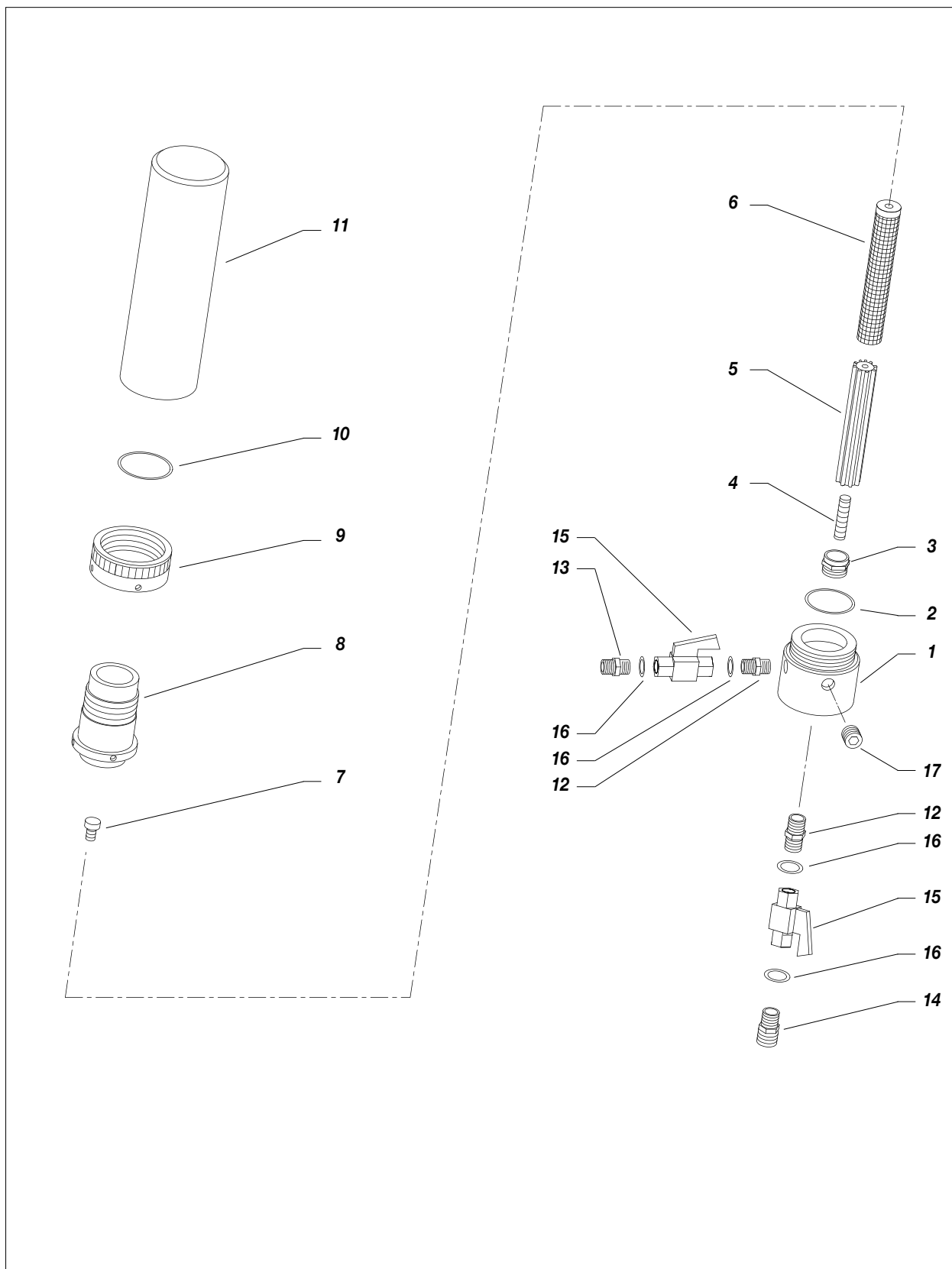



Nova 45:1/60:1

Pos.	Code	Description	Pos.	Code	Description
	95200	Complete line filter	8	95207	Intermediate fitting
1	95201	Filter base	9	95208	Ring nut
2	95202	O-ring	10	95209	O-ring
3	98303	Sieve fitting	11	96115	Filter container
4	95204	Hex socket set screw	12	95230	Fitting 3/8" - 3/8"
5	95205	Sieve support	13	95231	Fitting 3/8" G-M16x1,5
6	95218	Filter sieve 30 MESH	14	3387	Fitting 3/8" G-M20x2
6	95219	Filter sieve 60 MESH	15	33034	High pressure ball valve 3/8"
6	95220	Filter sieve 100 MESH	16	33010	Washer
6	95221	Filter sieve 200 MESH	17	95214	Plug 3/8" GAS
7	95206	Screw			

Version INOX

Nova 45:1/60:1

Pos.	Code	Description	Pos.	Code	Description
	98300	Stainless steel complete line filter	8	98307	Intermediate fitting
1	98301	Filter base	9	95208	Ring nut
2	95202	O-ring	10	95209	O-ring
3	98303	Sieve fitting	11	98090	Filter container
4	98304	Hex socket set screw	12	6149	Fitting 3/8" - 3/8"
5	95205	Sieve support	13	6148	Fitting 3/8" G-M16x1,5
6	95218	Filter sieve 30 MESH	14	3385	Fitting 3/8" G-M20x2
6	95219	Filter sieve 60 MESH	15	33037	High pressure ball valve 3/8"
6	95220	Filter sieve 100 MESH	16	33010	Washer
6	95221	Filter sieve 200 MESH	17	98385	Plug 3/8" GAS
7	98306	Screw			

**T COMPLETE HANDTRUCK**

Pos.	Code	Description
1	95150	Complete handtruck
2	95154	Wheels



U AIR GROUP COMPLETE

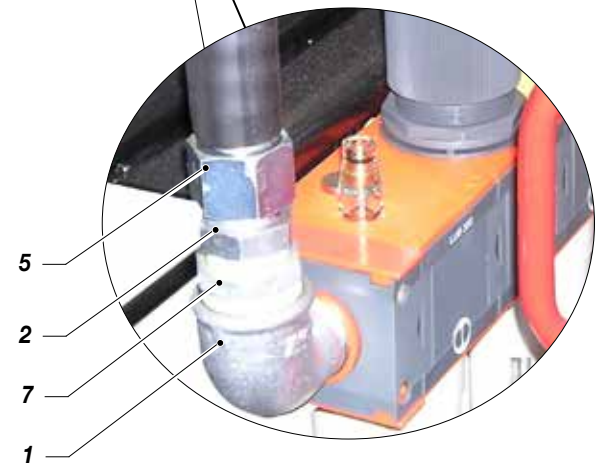
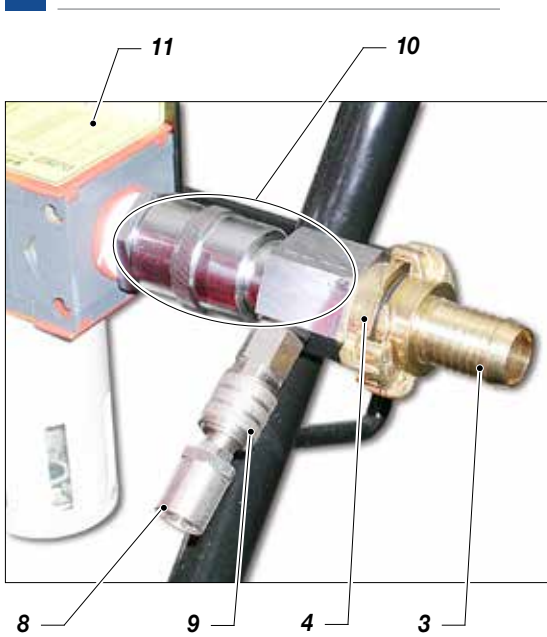

Pos.	Code	Description	Pos.	Code	Description
	95145	Air group complete	7	95313	Reduction 1" -3/4" Male Female
1	95031	Elbow Male Female 1" -MF92	8	95318	Rapid coupling 8x17
2	95090	Adapter 3/4 (NGE 3/4)	9	95319	Rapid coupling male da 1/4"
3	95301	Rapid coupling C/for rubber hose skg 25	10	95323	Valve 1"
4	95302	Rapid coupling 1"male	11	95350	Group F.R.L.
5	95308	Female fitting (FB 3/4X19)	12	96259	Manometer
6	95309	Hose tor/20NL 71N 19x29	13	95089	Elbow F-F 3/4"



V ACCESSORIES



Code 11250: AT 250 1/4"
Code 11200: AT 250 M16x1,5



Code 11000: AT 300 1/4"
Code 11090: AT 300 M16x1,5



Code 11180: L91X 1/4"
Code 11120: L91X M16x1,5



PISTON GUNSTOCK FILTERS
Code 11039: Green (30M) - Code 11038: White (60M)
Code 11037: Yellow (100M) - Code 11019: Red (200M)



FILTER
Code 95218: SIEVE 30M
Code 95219: SIEVE 60M
Code 95220: SIEVE 100M
Code 95221: SIEVE 200M



FITTING WITH MANOMETER
Code 147: M16x1,5
Code 150: 1/4"



Code 91044: PNEUMATIC MIXER



Code 7030: HP FLOW REGULATOR



Code 6099: HEATER



FAST-CLEAN

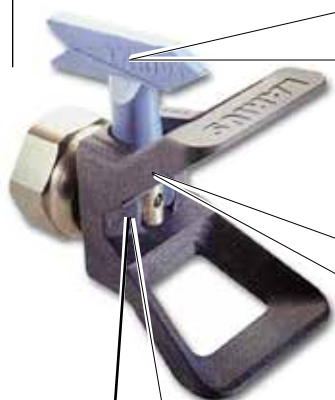

FAST-CLEAN TIP

Nozzles code		
07-20	19-60	29-80
07-40	21-20	31-40
09-20	21-40	31-60
09-40	21-60	31-80
11-20	23-20	33-40
11-40	23-40	33-60
13-20	23-60	33-80
13-40	25-20	39-40
13-60	25-40	39-60
15-20	25-60	39-80
15-40	27-20	43-40
15-60	27-40	43-60
17-20	27-60	43-80
17-40	27-80	51-40
17-60	29-20	51-60
19-20	29-40	51-80
19-40	29-60	



Code 18280: GASKET



Code 300: FAST-CLEAN base UE 11/16x16

SUPER FAST-CLEAN

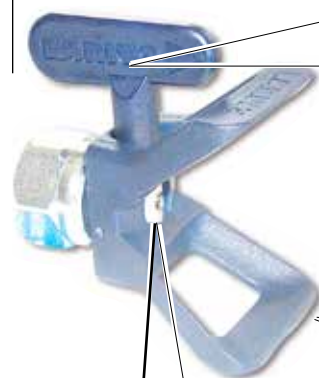

SUPER FAST-CLEAN TIP

Nozzles code		
SFC07-20	SFC19-60	SFC29-80
SFC07-40	SFC21-20	SFC31-40
SFC09-20	SFC21-40	SFC31-60
SFC09-40	SFC21-60	SFC31-80
SFC11-20	SFC23-20	SFC33-40
SFC11-40	SFC23-40	SFC33-60
SFC13-20	SFC23-60	SFC33-80
SFC13-40	SFC25-20	SFC39-40
SFC13-60	SFC25-40	SFC39-60
SFC15-20	SFC25-60	SFC39-80
SFC15-40	SFC27-20	SFC43-40
SFC15-60	SFC27-40	SFC43-60
SFC17-20	SFC27-60	SFC43-80
SFC17-40	SFC27-80	SFC51-40
SFC17-60	SFC29-20	SFC51-60
SFC19-20	SFC29-40	SFC51-80
SFC19-40	SFC29-60	



Code 18280: GASKET



Code 18270: SUPER FAST-CLEAN base UE 11/16x16



EXTENTION

- Code 153: cm 30
- Code 154: cm 40
- Code 155: cm 60
- Code 156: cm 100



- Code 95200: LINE FILTER
- Code 98300: LINE FILTER inox



- Code 95055: SUCTION SYSTEM
- Code 98055: SUCTION SYSTEM inox



- ANTISTATIC HOSE 3/16" - M16x1,5
- Code 6164: 5 mt
- Code 55050: 7,5 mt
- Code 35018: 10 mt



- HIGH PRESSURE HOSE 3/8" - M16x1,5
- Code 18063: 7,5 mt
- Code 18064: 10 mt
- Code 18065: 15 mt



AIRLESS PNEUMATIC PUMPS

OMEGA AIRLESS Art.-Nr. 7300
OMEGA AIR ASSISTED AIRLESS Art.-Nr. 7340



OMEGA ZINC Rif. 7430

SUPERNOVA Rif. 65100



VEGA AIRLESS Art.-Nr. 91500
VEGA AIR ASSISTED AIRLESS Art.-Nr. 91400



GHIBLI ZINC Rif. 96900

GHIBLI 30:1 Art.-Nr. 96000



GHIBLI MIX 2K 40:1 INOX: Rif. 24561



DESCRIPTION FOR EXPLOSIVE AREAS

These safety instructions refer to the installation, use and maintenance procedures for *NOVA* series *LARIUS* pneumatic piston pumps for decanting. These pumps are designed for use in potentially explosive areas where gas or vapours are present.



These instructions must be followed in addition to the warnings given in the user and maintenance manual.



NOVA series LARIUS pneumatic piston pumps are group II mechanical devices for use in the presence of gas in zones classified as IIB (category 2 G). They have been designed and constructed in accordance with ATEX Directive 94/9/EC and the European standards: EN 1127-1, EN 13463-1ed EN 13463-5.

TECHNICAL FEATURES

The main characteristics of *NOVA* series pneumatic piston pumps are indicated in the table below:

Ratio	Input pressure	Ø Air intake	Ø Material intake	Ø Material outlet	Ø Max working pressure	Max capacity
20:1	3 ÷ 6 bar	CG 3/4"	Ball valve	CG 1. 1/2"	120 bar	32 l/min
45:1	3 ÷ 6 bar	CG 3/4"	Ball valve	CG 1. 1/2"	270 bar	14 l/min
55:1	3 ÷ 6 bar	CG 3/4"	Plate	CG 1"	330 bar	12 l/min
60:1	3 ÷ 6 bar	CG 3/4"	Ball valve	CG 1"	360 bar	12 l/min
68:1	3 ÷ 6 bar	CG 3/4"	Ball valve	CG 3/4"	410 bar	11 l/min

- Environment temperature: -20°C ÷ +60°C
- Max. fluid temperature: 60°C
- Maximum number of cycles per minute: 60

MARKING



II 2 G c IIB T6 • E_{environment temp.:} -20°C ÷ + 60°C • M_{fluid temperature:} 60°C • Tech. File: NOVA/ATX/08

II =	Group II (surface)
2 =	Category 2 (zone 1)
G =	Explosion hazardous environment with presence of gas, fog and vapour
c =	Manufacturing safety "c"
T6 =	Class of temperature T6
- 20°C ÷ + 60°C	Environment temperature
60°C	Maximum fluid temperature
xxxx/AA	Serial number (xxxx = PROGRESSIVE/ year = AA)

Relation between hazardous areas, products and categories

DANGEROUS AREA		CATEGORIES AS PER RULES 94/9/CE
Gas, vapour or fog	Zone 0	1G
Gas, vapour or fog	Zone 1	2G or 1G
Gas, vapour or fog	Zone 2	3G, 2G or 1G



SAFETY INSTRUCTIONS FOR ONSTALLATIONS IN HAZ-ARDOUS AREAS

 Before proceeding with the installation carefully read the use and service manual. All the service operations must be carried out as stated in the manual.

- The M.T. cable of the above mentioned pumps must be grounded by means of an appropriate anti-loosening connection element.
- The pipes used to connect suction and delivery must be metallic, or plastic with metallic braid or plastic with fabric braid with suitable earthing cable.
- The pumps must be installed upon grounded barrels made from metallic or anti-static materials.
- Gas and vapour of flammable liquids must belong to the group IIB.
- According with the nature of the operations and products, the operator must regularly check the presence of deposit, the cleaning, the wearing and the correct pump's functioning.
- The user must periodically clean the filter located upon the suction unit in order to prevent solids from reaching the pump's internal elements. The air feeling the pump needs to be filtered and originated by a safe area. (SAFE AREA).

 The NOVA series pneumatic piston pumps must not be made to run without a proper load.

 All the operations, installation and service, must be carried out by qualified operators.

SAMPLE DECLARATION OF CONFORMITY

We Larius S.r.l.
Via Stoppani, 21
23801 Calolziocorte (LC)

declare under our sole responsibility that the product

NOVA series pneumatic piston pumps for decanting

to which this declaration relates complies with the following Directives:

- Directive 94/9/EC (ATEX)

The conformity are under observance of the following standards or standards documents:

- EN 1127-1
- EN 13463-1
- EN 13463-5

Marking

CE  II 2 G c IIB T6 • Eanvironment temp.: -20°C ÷ + 60°C
• M. fluid temperature: 60°C • Tech. File: NOVA/ATX/08

Technical file: NOVA/ATX /08

Technical file c/o: INERIS (0080)

Calolziocorte- LC

Signature (LARIUS)

EXAMPLE OF INSTALLATION



The diagram illustrates a typical installation example of a LARIUS pneumatic piston pump for decanting.

Intentionally blank page



CE DECLARATION OF CONFORMITY



Company



LARIUS srl
Via Antonio Stoppani 21 - 23801 Calolziocorte (LC) ITALY
Tel: +39 0341 621152
Fax: +39 0341 621243
E-mail: larius@larius.com

Declares under his owns responsibility that the product:

NOVA 45:1 60:1 **Pneumatic airless pump**

complies with the directives: | - EC Directive 2006/42 Machinery Directive

furthermore to the
harmonized standards: | - UNI EN ISO 12100-1/-2
Machinery safety, basic concepts, general principles of design. Basic terminology, methodology. Technical principles.

This declaration relates exclusively to the product in the state in which it was placed on the market, and excludes components or modifications which are added or carried out subsequently by end user.

Signature

Pierangelo Castagna
Managing Director

Calolziocorte, 27 August 2020
Location / Date



LARIUS srl

Via Antonio Stoppani 21 - 23801 Calolziocorte (LC) ITALY
TEL. +39 0341 621152 - Fax +39 0341 621243 - larius@larius.com

www.larius.com

