

ENG

VITRIFRIGO

COOL AND BEYOND

INSTRUCTION MANUAL

SERIES DRW

ALL IN ONE

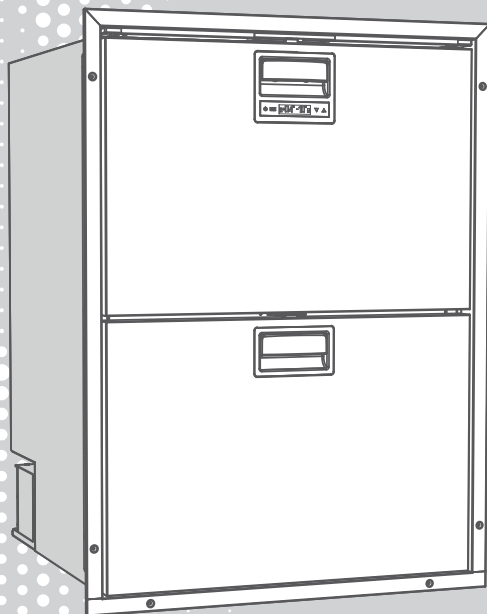

THANK YOU FOR PURCHASING A VITRIFRIGO PRODUCT

Index

1. INTRODUCTION	24
2. GENERAL WARNINGS	24
Product uses	24
Upon receiving the product	25
Installation	25
Maintenance and safety	26
Disposal	26
3. PURPOSE OF THE MANUAL	27
The manufacture	27
4. DESCRIPTION OF THE APPLIANCE	27
5. INSTALLATION	28
Appliance recess	29
Types of recess	29
Fixing the cabinet	30
Defrost water drain	30
Fixing the front profile	30
Fixing the cell	30
Adjusting the drawers	30
Fixing the thermostat display (only for no inox panel version)	31
6. ELECTRICAL CONNECTION	32
Connection to the electrical network (VAC) - optional	32
Battery connection	32
7. POWERING ON	33
Control panel	34
Switching on / Turning off	34
Setting the operation mode / All in one	35
Changing the temperature setting	35
Locking the keypad	36
Defrosting / Total no frost	36
Anti-mould function	36
8. MAINTENANCE	37
Cleaning the refrigerator	37
Removing the drawers	37
Replacing the LED light profile from the upper drawer	37
9. ALLARMS	38
Silencing allarms	40
10. WHAT TO DO IF THE REFRIGERATOR DOES NOT WORK	40
11. TECHNICAL SPECIFICATIONS	41
ANNEXES	102

1. INTRODUCTION

Dear client:

Thank you for choosing one of our products.

VITRIFRIGO hopes that you will be completely satisfied by your purchase.

This manual is an integral part of the refrigerator and must accompany the refrigerator should it be sold or passed on.

Each refrigerator, before being shipped, is thoroughly checked and tested to ensure it operates correctly. For more information or for any clarification, please contact one of our service centres or any of our offices directly.

Vitri Alceste

Models

DRW70A

DRW180A

DRW360A

2. GENERAL WARNINGS

- This manual refers to models from the DRW series.
- Read this manual carefully before using the refrigerator.

ATTENTION risk of fire. The appliance contains flammable gas (propane R290 or Isobutane R600a).

ATTENTION Do not damage the refrigerant circuit.

ATTENTION Do not use electrical appliances or devices inside the food storage compartments if these appliances or devices are not of the type(s) recommended by the manufacturer.

ATTENTION Keep ventilation openings in the equipment's casing or in the recess free from obstruction.

ATTENTION Do not use mechanical devices or other means other than those recommended by the manufacturer to accelerate the defrosting process.



Product uses:

- This appliance is designed for use in applications such as:
 - kitchen areas for personnel in shops, offices and other work environments;
 - customers of farms, hotels, motels and other residential environments;
 - Bed and Breakfast establishments;
 - camper, roulotte e imbarcazioni da diporto.
 - catering services and similar applications but not for retail purposes.
- This appliance may only be used with a built-in (recessed) installation.
- Follow the installation instructions given in this manual carefully.
- It is absolutely prohibited to use the refrigerator for any use other than those intended.

- The appliance may be used by children aged 8 and older and by people with reduced physical, sensory or mental abilities, and by people lacking experience or the necessary knowledge, provided that use is supervised or done after suitable instruction has been given regarding the safe use of the appliance and once there is an understanding of the danger inherent in the product and its use.
- Children must not play with the appliance.
- Cleaning and maintenance by the user must not be done by children without the proper supervision.

Upon receiving the product

- Check that the packaging is intact. If not, report it to the courier.
- Remove the refrigerator from the packaging, taking the utmost care and caution to avoid accidentally damaging the product. Use protective gloves, especially for models with a remote refrigeration unit.
- Check that the product has not been damaged. Any damage must be reported to the reseller within 24 hours of taking delivery of the appliance.

Installation

- Install the product, taking the utmost care and caution to avoid accidentally damaging the product. Use protective gloves.
- Before connecting the refrigerator, check that the network voltage corresponds with that displayed on the equipment's identification label, or with that indicated on the label on the compressor.
- Once installation has been completed, check that the refrigerator is not resting on a power cable.
- If the power cable is damaged, it must be replaced immediately by someone from the technical service centre or by someone suitably qualified.
- Place the refrigerator away from heat sources, making sure that there is sufficient ventilation.
- We recommend that you wait at least one hour before switching the refrigerator on, in order to allow the refrigeration circuit to be completely efficient.
- We recommend leaving sufficient space to be able to disconnect the appliance from the power supply, should the need arise.
- DRW series refrigerators are for in-built (recessed) installation.

ATTENTION **To avoid any hazard caused by the appliance being unstable, it must be fixed according to the instructions.**

Maintenance and safety

- Before carrying out any maintenance or cleaning operation, disconnect the power plug.
- Keep ventilation openings free from obstructions. Contact a suitably qualified person to clean the ventilated condenser.
- Always carry out the inspections, checks, and scheduled maintenance described in this manual.
- Never try to open or repair the refrigerator.
- For any operational problems contact the Vitrifrigo Service Centre closest to you; in any case, request the assistance of a suitably qualified person.
- Do not store explosive substances in this appliance such as aerosol cans with flammable propellant.
- The appliance must not be cleaned with a jet of water.
- For appliances intended to be used at altitudes higher than 2000 m, contact the manufacturer.
- The environment in which the appliance is installed must be adequately ventilated if possible.
- If the environment, in which an appliance containing a flammable refrigerant is used, is not ventilated, the environment must ensure that, should any gas leak, it cannot reach a concentration such as to cause a fire or explosion as a result of a heat source (electric heating appliances or similar).

Disposal

- Do not throw the packaging used for your appliance away. Separate the materials according to local waste disposal regulations.
- This product must not be disposed of with municipal waste but must be disposed of separately. Contact your nearest Waste Electrical and Electronic Equipment (WEEE) collection centre or take it to a retailer when purchasing a new, equivalent appliance.
- The symbol shown above indicates that the refrigerator cannot be disposed of as household waste.
- Improper disposal or incorrect use of the refrigerator is subject to administrative and/or penalties imposed by current legislation.



3. PURPOSE OF THE MANUAL

This manual, referring to DRW series refrigerators, is intended as a guide to the appliance's proper use and maintenance.

In order to learn how to operate and use the refrigerator, you must read this manual carefully.

This manual contains the operations related to: installation, operation, maintenance.

The refrigerator has been manufactured to comply with all the safety requirements given by legislation and regulations.

Nevertheless, the user's utmost safety depends on carefully reading this manual and on regular and careful cleaning and maintenance.

Some information or diagrams in this manual may show details or particular aspects that might differ slightly from the refrigerator that you have purchased.

The essential information, however, remains the same.

Depending on the constant improvement of models, this refrigerator may show variations that are not covered in this manual.

Any modifications will appear, depending on the need, in future versions of the manual.

Manufacturer identification

The refrigerator has been design and manufactured exclusively by:

Vitrifrigo s.r.l.

Via Mazzini 75 - fraz. Montecchio - 61022 VALLEFOGLIA(PU) - Italia

tel. +39 0721 154500 - fax. +39 0721 497739

e-mail info@vitrifrigo.com - www.vitrifrigo.com

4. DESCRIPTION OF THE APPLIANCE

- The label showing the serial number and the technical data is placed inside the refrigerator. The first four digits of the serial number identify the year and the week of manufacture.
- The DRW series refrigerators - No frost All in one, to which this manual refers, has been designed to meet the superior requirements demanded, in order to guarantee that food is properly conserved.

• **DRW70A**

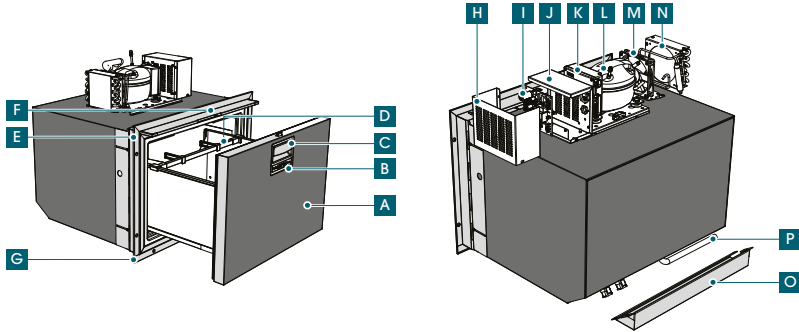

A) Drawer	G) Base profile	M) Fan
B) Command display	H) Grille cover tag	N) Condenser
C) Handle	I) Electronic board	O) Back protection
D) Internal partition	J) Electronic board seat	P) Drain tube
E) Fixing profile	K) Control Unit	
F) Handle lock	L) Compressor	

• **DRW180A / Bottom DRW360A**

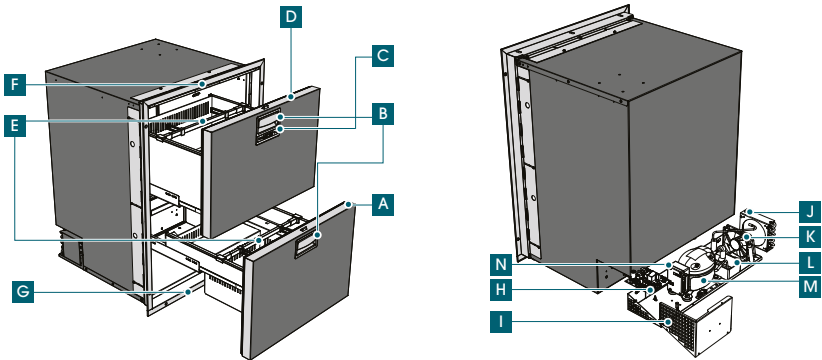

A) Lower drawer	F) Fixing profile	K) Fan
B) Handle	G) Base profile	L) Condensation collection tank
C) Command display	H) Electronic board	M) Compressor
D) Upper drawer	I) Grille cover-tag	N) Control unit
E) Internal partition	J) Condenser	

- **DRW360A - Top**

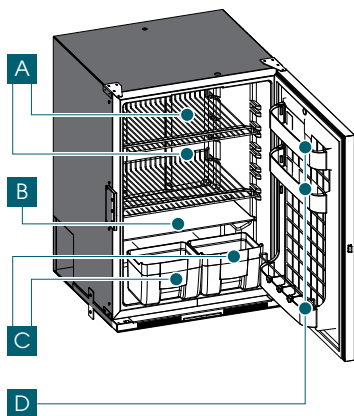

A) Removable grilles
B) Removable glass shelf
C) Fruit basket
D) Removable door shelves

5. INSTALLATION

When opening the packaging, after having received the appliance, check that it is not damaged. Any transportation damage must be reported promptly to the reseller and, in any case, within 24 hours of taking delivery of the appliance. Handle the product with the utmost care and attention. When positioning the refrigerant unit (in refrigerator models with a remote refrigerant system), take precautions to avoid obstructions and breaking the connection pipes. Always position the refrigerator and the remote refrigerant unit (in the versions with such a solution) on a horizontal surface that can support the weight of the appliance and its eventual contents. Always position the remote refrigerant unit (in the versions with such a solution) to ensure an adequate ventilation and away from heat sources. Once installation has been completed, check that the refrigerator is not resting on a power cable. If the power cable is damaged, it must be replaced immediately by someone from the technical service centre or by someone suitably qualified, in order to avoid any risk. Place the refrigerator away from heat sources, making sure that there is sufficient ventilation, as can be seen in the following installation examples.

Once the refrigerator has been positioned, wait at least one hour before switching it on.

Appliance recess

The dimensions of the compartment to be provided for building the appliance in, in order to guarantee its stability, must allow the correct assembly of the installed fixing profile. (Attached 1). *Recess depth dimension depend on the thickness of the front panel used.

ATTENTION **Keep ventilation openings free from obstructions in the recess and in the compartment housing the remote refrigerant unit (in the versions with such a solution).**

Make sure that the refrigerator unit is adequately ventilated by arranging for two side openings in the storage unit in line with the two air ducts on the technical compartment. Do not place anything over the ventilation grilles, nor cover them. The recess must respect the minimum distances between the appliance and the surrounding structure, and must have adequate ventilation opening onto the room's free environment in order to achieve correct air circulation through the chimney effect, as indicated in figure. The recess must ensure that no electrically live part of the appliance is directly accessible (electronic board, control unit and fan), equipping them with appropriate grilles as per the ventilation openings.

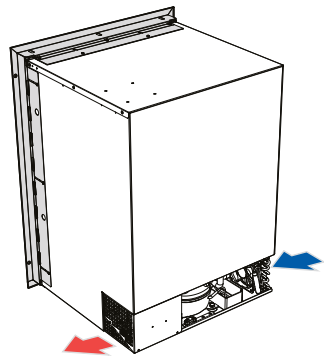

The grilles must have openings with dimensions of max. 5mm and they must be on at least one side (Attached 2). The ventilation openings must have a minimum height not less than 75mm and must have dimensions no smaller than the refrigerator's in terms of width if positioned above or below the appliance, or height not less than 120mm and width not less than 120mm if positioned behind (Attached 2).

The minimum distances between the various parts of the appliance and the recess structure must not be less than 75mm. For recess situations in compartments in which the minimum distance of 75mm is only respected at the rear of the appliance, you must provide for ventilation openings on the same side, respecting the instructions for their placement, their number and their dimensions as shown in figure. For recess situations with shelves in contact with the upper and lower parts of the appliance, you must provide for ventilation openings above and below the appliance, as shown in (Attached 2) or in the rear part. In all the situations of the described ventilation openings, just the minimum distance of 75mm from the sides of the appliance may not be observed. (Attached 2)

Types of recess

For the whole series (except the no inox panel versions) is possible to install the cabinet in the two ways below:

- Total recess (door inside - door flush with the front side of the fixing profile): prepare the profile and the base profile, supplied as a kit, as shown in the diagram using the screws already installed (see single arrows).
- Partial recess (door outside - door closes proud of the front side of the fixing profile): prepare the profile and the base profile, supplied as a kit, by making it slide in the direction of the double arrows.

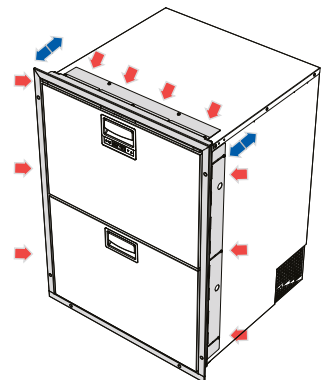

Fixing the cabinet

Defrost water drain

In the model without automatic disposal of the defrost water (model with remote refrigerant unit) connect the drainpipe fig. 5.9 (with inner diameter of 12 mm) to the water disposal network before fixing the cabinet.

Fixing the front profile

Once the fixing profile's position has been defined, and the refrigerator has been introduced into the dedicated compartment, fix the profile by using the holes provided. (Attached 3, fig.1)

Fixing the cell

After having introduced the refrigerator into its compartment in the definitive position, make the holes in the cell in the positions shown in the diagrams. To access all the points described, you will need to remove both drawers and remove the plugs from their seats. Drill with a metal drill bit, diameter 3.5mm. It is better to use 4.5x45 non-countersunk, chipboard screws. Once installed, cover the bushings with the plugs provided. (Attached 3, fig.2)

Adjusting the drawers

The refrigerator comes with two drawers that have been adjustable to provide proper operation and a good exterior appearance with a proportioned tile layout.

In the event that the drawers need to be adjusted, proceed as follows.

Open the drawer and remove the metal clip on the inner side.

Use the screws indicated to raise or lower the drawer (screw 1) or to move the side to the left or the right (screw 2).

The maximum storage capacity of a single drawer is 70 kg. There is a railing inside the drawers for dividing food.

Screw 3 releases the drawer front. Danger of the door falling.

Use this screw only with due care and attention.

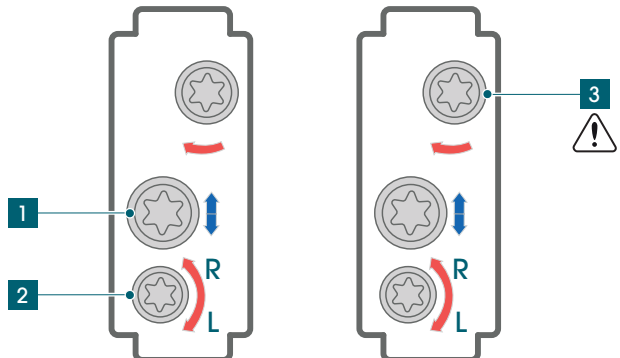

Fixing the thermostat display (only for no inox panel version)

In the version without inox panel the digital thermostat display will be supplied as kit like shown in the figure below:

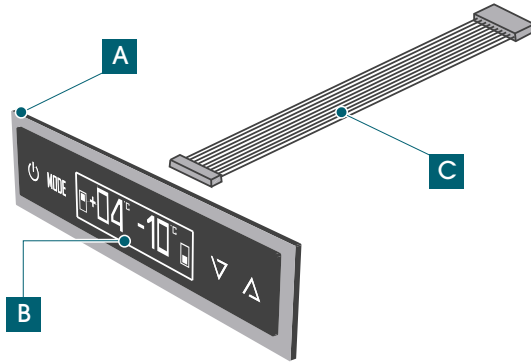

A) Inox frame	B) Command display	C) Display extended cable
---------------	--------------------	---------------------------

The display dimensions are shown in the Attached 4 . We recommend to realize a suitable seat for the display housing in the front panel used to cover the drawer.

The housing of the display have to be in the middle of the panel and not more than 80 mm from the top of the panel.

Only for the DRW180A without inox panel is preferred to realize in the bottom of the panel an housing for the two led lights as shown in the figure 5.18.

Before the panel installing connect the cable of the display on the cable came from the drawer.Turn on the unit and verify the correct functionality of the display.

6. ELECTRICAL CONNECTION

Connection to the electrical network (VAC) - optional

The refrigerator connects to the electrical network by plugging it into an electrical socket. If the plug is not present replace the socket with a suitable one. This operation must be done by a suitably qualified person who must ensure that the cable section of the plug is appropriate to the power absorbed by the appliance. The power outlet must be firmly installed and appropriately earthed. Check that the voltage and the frequency correspond to the refrigerator's nominal data as shown on the product label. Connection is via a power cable with plug supplied. The voltage must not undergo variations greater than $\pm 5\%$. Provide a differential thermal-magnetic breaker switch ($I_{\Delta n}=0.03$ A), 6A, type C. The remote switch must disconnect all the poles from the electrical supply, must guarantee an opening of at least 3mm and must be safe in the event that the electricity is accidentally reactivated. In the case of any doubt, consult a suitably qualified technician. Run the electrical cables in such a way as to avoid any risk of tripping or of causing damage.

The electrical cable must not come into contact with any part that could reach a temperature greater than 50°C.

Before connecting the product, make sure that the voltage corresponds to that shown on the identification label or that shown on the label on the compressor.

ATTENTION by law, the equipment must be earthed. Make sure that the earthing system for the electrical network is working perfectly.

We accept no responsibility whatsoever for any injury to people or damage to property deriving from the failure to properly comply with this regulation.

The use of adaptors, multiple sockets and extension cords is not recommended.

In the event that the appliance's plug and the socket are not compatible, replace the plug with a suitable one. This operation must be done by a suitably qualified person who must ensure that the cable section of the plug is appropriate to the power absorbed by the appliance. Do not interconnect any other type of appliance to the refrigerator.

Battery connection

Connect the 12VDC or 24VDC power line, where present, directly to the battery, following the instructions below.

Connect the refrigerator to the battery using the special cables provided.

RESPECT THE POLARITY

Sec. (mm ²)	Max.lin.length 12V (m)	Max.lin.length 24V (m)
2.5	2.5	5
4	4	8
6	6	12
10	10	20

Check that the battery's nominal voltage corresponds to the refrigerator's nominal data shown on the product label. Provide a 25 A thermal-magnetic breaker type remote voltage switch. The remote switch must disconnect both the poles of the battery. If the power cables to the battery are extended, use appropriate connections that are able to support the minimum current of 20 Amperes. Use wires with a minimum section and a maximum length as given in the table.

STANDARD BATTERY PROTECTION SETTINGS

12 V		24 V	
Cut-out	Cut-in	Cut-out	Cut-in
10.4	11.7	22.8	24.2

7. POWERING ON

Once installation has been completed, check the continuity of the earth circuit and carry out all the electrical safety tests provided for by current regulations. Protect and adequately block the cables to avoid any risk of accidentally pulling the cable which could disconnect it or which could cause it to come into contact with a hot part of this appliance (or another one) at a temperature over 50°C or with a sharp part. If the power cable is damaged, it must be replaced by the manufacturer or by the manufacturer's technical service centre or, in any case, by a person similarly qualified, in such a way as to prevent any risk.

- Make sure that all the packaging materials have been removed.
- Test all piping to make sure that there are no leaks.
- Check all the electrical connections.
- Check that the drawer can be removed from the appliance.
- Check that the door can be closed properly.

Before putting any food into the refrigerator, carefully clean the inside with warm water and bicarbonate of soda. The appliance is equipped with a motor protection control which starts the compressor only after 3 minutes from the last power on. This also happens after any interruption in the electrical supply, whether voluntary or involuntary (a blackout).

i To avoid excessive condensation in the refrigerator, cover liquid products and let hot products cool before putting them into the refrigerator.

i To reduce cooling time, only put previously cooled foods into the refrigerator. To prevent food from drying out, or the refrigerator assuming an undesirable smell, store food in sealed containers, separately.

Control panel

The panel has a capacitive touch screen keypad and an OLED display. The lightest touch of your finger is enough to active a button. The display does not work with inanimate objects, nails, gloves, etc. In order to keep the buttons efficient, clean the keypad with a damp cloth.

- **DRW180A / Bottom DRW360A**

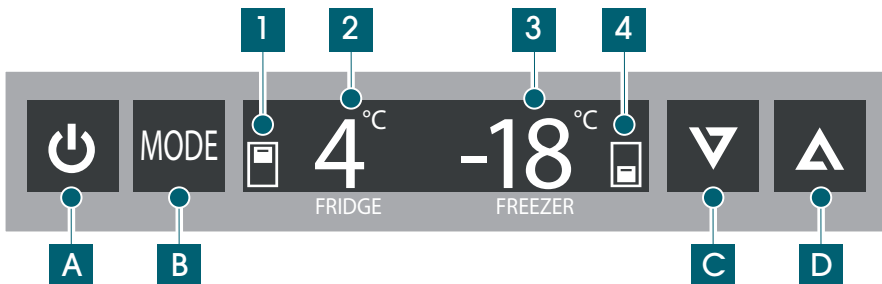

A	On / Stand by	1	Upper drawer reference
B	Mode	2	Upper setpoint indicator
C	Down (down arrow)	3	Lower setpoint indicator
D	Up (up arrow)	4	Lower drawer reference

- **DRW70A / Top DRW360A**

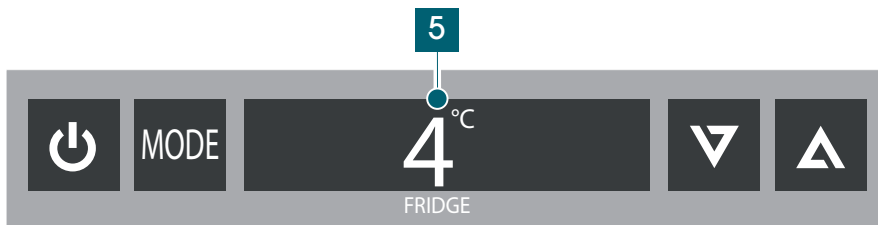

5	Drawer set point indication
----------	-----------------------------

Switching on / Turning off

When the power supply is connected, the display switches on in Stand By mode and displays the writing "VITRIFRIGO".

To switch the refrigerator on, press and hold button A for 2 seconds. Once on, all the functions are enabled. If more than one power source is available (VDC and VAC), power is selected automatically, with the AC source taking precedence.

Pressing the A button again and the unit passes, alternatively, from the Stand By mode to On.

Setting the operation mode / All in one

- **DRW180A / Bottom DRW360A**

The unit can operate in one of 3 distinct modes by simply selecting it from the display. To set one of the three modes, press and hold button B for 3 seconds and then refer to the following table:

Total fridge	This mode allows both drawers to be used in fridge mode. Hence the temperature is positive at +4°C / +4°C. To activate this mode, press button B repeatedly until you reach the display with both drawers at +4°C fridge-fridge. Confirm by pressing and holding button B for 3 seconds.
Fridge / Freezer	This mode allows the lower drawer to be used as a freezer and hence the temperature is negative whilst the upper drawer is used as a refrigerator and hence the temperature is positive. To activate this mode, press button B repeatedly until you reach the display with the upper drawer at +4°C fridge and the lower drawer at -18°C freezer. Confirm by pressing and holding button B for 3 seconds.
Total freezer	This mode allows both drawers to be used in freezer mode. Hence the temperature is negative. To activate this mode, press button B repeatedly until you reach the display with both drawers at -18°C freezer-freezer. Confirm by pressing and holding button B for 3 seconds.

• DRW70A

The unit can operate in one of 2 distinct modes by simply selecting it from the display. To set one of the three modes, press and hold button B for 3 seconds and then refer to the following table:

Total fridge	This mode allows the drawer to be used in fridge mode. Hence the temperature is positive at +4°C. To activate this mode, press button B repeatedly until you reach the display with the set point at +4°C fridge. Confirm by pressing and holding button B for 3 seconds.
Total freezer	This mode allows the drawer to be used in freezer mode. Hence the temperature is negative -18°C. To activate this mode, press button B repeatedly until you reach the display with both drawers at -18°C freezer. Confirm by pressing and holding button B for 3 seconds.

If no mode has been confirmed after 60 seconds, the system will confirm the last mode shown on the display. You can change the mode at any time.

The time to reach the new set temperatures depends on a range of issues such as, environmental factors, drawer load, etc.



When switching from Total fridge to Total freezer, the time to reach the new temperature can be quite long (8-12 hours).

• DRW360A - Top

The unit can operate in one mode.

Total fridge	This mode allows the drawer to be used in fridge mode. Hence the temperature is positive at +4°C.
---------------------	---

Changing the temperature setting

When setting up the modes, pre-defined temperature setpoints have been set to optimise the unit's automatic operations. It is possible, however, to change these settings using the arrows C and D. To change the setpoints, press and hold button C or D for at least 2 seconds. In order, the setpoint for the lower drawer and then the setpoint for the upper drawer will be displayed. Press button C or D (up arrow or down arrow) to change these setpoints and confirm with button B.

Having confirmed the "INF" (lower) drawer, the display goes to the "SUP" (upper) drawer. After making your changes, press B to confirm. The new setpoints will be displayed.

The setpoints can be changed within a pre-set range:



-20 / - 15 °C for freezer mode
+2 / +8 °C for fridge mode



The lower the temperature setting, the more power consumed by the unit.

Locking the keypad

The keypad locks and the message LOCK is displayed with a flash after 60 seconds from the last button being pressed. Press and hold any button for 2 seconds to unlock the keypad. The message UNLOCK is displayed with a flash.

Defrosting / Total no frost

The DRW180A unit has an automatic defrosting system that, at regular intervals, restores the cooling system's performance.

The condensation collected during these phases is automatically expelled and evaporates in the technical compartment, while in the model with the remote refrigerant unit the defrost water has to be disposal in the water network.

In addition, the unit has internal fans to distribute the temperature and to reduce condensation on the unit's walls. (Attached 6)

Avoid obstructing the air ducts, air paths and the fan vents, indicated by the arrows.

Anti-mould function

When the unit is not in use, it is set up to prevent unpleasant smells and mould from forming inside the compartment. Once the refrigerator is turned off and emptied, you must open the upper drawer and remove the mechanism in the middle of the lid (see drawing).

Push the two buttons and extract the mechanism until it "clicks", which means the mechanism has been locked. Carefully close the upper drawer so that it stays slightly open (about 1cm). To reposition the drawer when in operation, open the drawer by the main handle and replace the ventilation mechanism by pressing the two buttons highlighted by the arrows in the drawing.

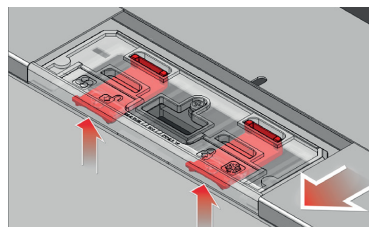

The mechanism locks at the end of its travel range and the refrigerator is ready to return to normal operation.

8. MAINTENANCE

Cleaning the refrigerator

OUTSIDE

Clean the outside of the refrigerator with a sponge or soft cloth. Do not use solvents or abrasive products.

INSIDE

Clean the inside with warm water and some bicarbonate of soda or vinegar. Rinse and dry carefully with a soft cloth. Do not use abrasive products. If the appliance is not going to be used for a prolonged period, in order to avoid mould and unpleasant smells,

remove the plug, empty the refrigerator and clean the inside before leaving the door ajar.

Removing the drawers

The drawers may be removed for cleaning and maintenance purposes.

To remove the upper drawer, first disconnect the spring cable highlighted in the diagram, then press the levers. (Attached 5)

To remove the spring cable, use a certain amount of force on the connector (dashed arrow) and rotate the ring nut by 90° anti-clockwise.

Once the connection has been removed, apply pressure to the levers (solid arrows) and remove the drawer. To remove the lower drawer, press the side levers since there is no connector to release.

Replacing the LED light profile from the upper drawer

ATTENTION: Before replacing the light, make sure that the refrigerator is not connected to any electrical supply. If connected, unplug the appliance from the electrical supply. Replacing the LED light must be done by a suitably qualified person who is able to adopt all the appropriate safety measures.

The DRW series refrigerators have LED lights magnetically controlled by opening/closing the drawers. In the module with two drawers, you can replace the upper drawer's light. To replace the LED light profile:

- 1 Remove, perpendicular to the base, the protective cover, being careful not to damage the fixing pins.
- 2 Disconnect the light's power cables.
- 3 Replace the LED light profile.
- 4 Connect the power source.
- 5 Replace the cover.

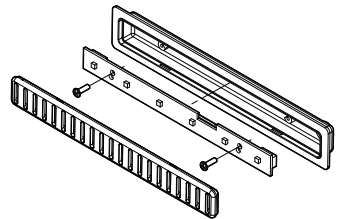

9. ALARMS

Alarms are displayed, alternating with the setpoint, every 2 seconds and they appear in rotation. At the same time, an alarm sound is generated.

The alarms of **DRW SERIES**.

Alarm	Description	Possible cause(s)	Effect	Solution
E1	Lower drawer sensor error	Faulty sensor	The refrigerator continues to operate temporarily in recovery mode	We recommend removing any food, turning the refrigerator off and immediately contacting the service centre
E2	Upper drawer sensor error	Faulty sensor	The refrigerator continues to operate temporarily in recovery mode	We recommend removing any food, turning the refrigerator off and immediately contacting the service centre
E3	Evaporator sensor error	Faulty sensor	The refrigerator continues to operate temporarily in recovery mode	We recommend removing any food, turning the refrigerator off and immediately contacting the service centre
E4	External sensor error	Faulty sensor	Information only The refrigerator continues to operate normally	Report the fault to the service centre
Door 1	Lower drawer open	The alarm activates after the drawer has been left open for over 1 minute	The cooling fans stop and any food may start to perish	Close the drawer. If the problem persists, contact the service centre
Door 2	Upper drawer open	The alarm activates after the drawer has been left open for over 1 minute	The cooling fans stop and any food may start to perish	Close the drawer. If the problem persists, contact the service centre
A1	Lower compartment high temperature alarm	The temperature detected in the lower compartment is too high (E1)	Information only The refrigerator continues to operate normally	Check that there are no heat sources inside the compartment
A2	Upper compartment high temperature alarm	The temperature detected in the upper compartment is too high (E2)	Information only The refrigerator continues to operate normally	Check that there are no heat sources inside the compartment
A3	Evaporator high temperature alarm	The temperature detected in the evaporator is too high (E3)	Information only The refrigerator continues to operate normally	If the problem persists, contact the service centre
Erd	Short defrost alarm	Insufficient power supply	The evaporator could fill up with ice. The refrigerator continues to operate normally, but it may have poor performance	Check voltage and power supply. The alarm disappears at the next successful defrost. If the problem persists, contact the service centre
dFd	Long defrost alarm	Insufficient power supply. Lot of ice in the evaporator. Air infiltrations from outside.	The evaporator could fill up with ice. The refrigerator continues to operate normally, but it may have poor performance	The alarm disappears at the next successful defrost. If the problem persists, contact the service centre
Link	The control panel is not communicating with the main board	The upper drawer connection may be compromised	Information only	If the problem persists, contact the service centre
Batt 12V Batt 24V	Battery pre-alarm	The power supply voltage has dropped below a warning level	For information The refrigerator continues to operate normally	Keep a watch on the power supply
A-Batt 12V A-Batt 24V	Battery alarm	The power supply voltage has dropped below the minimum safety level	Turn the refrigerator off to protect the battery	Wait until the power supply voltage goes back above the minimum level

Silencing alarms

You can deactivate the sound of the alarm at any time by pressing any button on the keypad

10. WHAT TO DO IF THE REFRIGERATOR DOES NOT WORK

Problem	Possible cause(s)	Solution
The refrigerator/freezer does not work. The temperature in the refrigerator/freezer is too high.	The power cable plug has not been properly plugged into an electrical socket.	Plug the power cable in properly.
	The temperature control has not been set correctly.	Set a lower temperature.
	The refrigerator is positioned next to a heat source or is exposed to direct sunlight.	Make sure that the refrigerator is positioned away from direct sunlight and any heat sources
	There is not enough space between the refrigerator and the sides/back.	Make sure that there is at least 2 cm of space between the back and side walls of the cabinet
	The refrigerator is too full. Food blocks the ventilation openings.	Do not overfill the refrigerator. Make sure that food does not obstruct the ventilation openings
The refrigerator/freezer cools excessively.	The temperature control has not been set correctly.	Set a higher temperature
The part of the metal frame around the refrigerator is hot	The refrigerator is equipped with thermally insulated pipes on the front frame that prevent condensation from forming on the door seal when the drawer is closed	In order to prevent condensation from forming, the refrigerator is equipped with insulated pipes on the front frame. This does not mean that there is a problem or fault in the system
There is an unpleasant smell in the refrigerator	Food has spoilt	Clean the refrigerator and remove any spoilt food.
	Food has a strong smell	Wrap food that has a strong smell in film.
Frost has formed on the inside walls	The door was not properly closed	Make sure that food does not prevent the drawer from being properly closed. Clean the drawer seal
	Food blocks the ventilation openings.	Make sure that food does not obstruct the ventilation openings
Condensation has formed on the inside walls	If the drawer is left open, humidity can enter the refrigerator.	Remove the humidity and do not open the drawer for a long period of time.
	Food with high moisture content.	Wrap the food in film.
The refrigerator does not stop	The internal temperature is too high	Check that the drawers close tightly
	Try running a reset	Disconnect the power cable. Wait for a minute and then reconnect it. Try switching the unit on again.
The courtesy light does not switch on	The light is faulty	Call the service centre
The refrigerator is noisy		Check that the refrigerator sits flat and is not in direct contact with any object that might cause vibrations

11. TECHNICAL SPECIFICATIONS

Parameter	Value		
Power Supply	12-24 Vdc	All	
	220-240Vac / 50-60Hz	1, 2	
Max Consumption – Normal operation	8A @ 12Vdc	1, 2	
	4A @ 24Vdc		
	4A @ 12Vdc	3	
	2A @ 24Vdc		
Max Consumption during defrost	10,5A @ 12Vdc (126W)**	1, 2	
	10,5A @ 24Vdc (252W)**		
Climatic Class	T	1, 2	
	N	3	
Refrigerant 	R290	1, 2	
	R600a	3	
Refrigerant quantity	(R600a)	0,034 kg	3
	(R290)	0,032 kg	2
	(R290)	0,034 kg	1
CO2 equivalent	< 0,0001 t	All	
Global warming potential (GWP)	3	All	
Weight	100 kg	2 + 3	
	55 kg	2	
	38 kg	1	

DRW360A

DRW70A



DRW180A

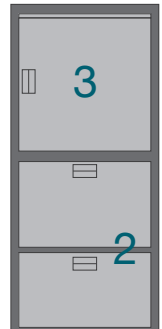
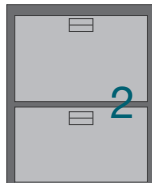

ATTENTION If an external 12/24Vdc power supply is used, refer to the power values ** increased by 20%.