

ENG

VITRIFRIGO

COOL AND BEYOND

INSTRUCTION MANUAL
FRIDGES AND FREEZERS

DW SERIES

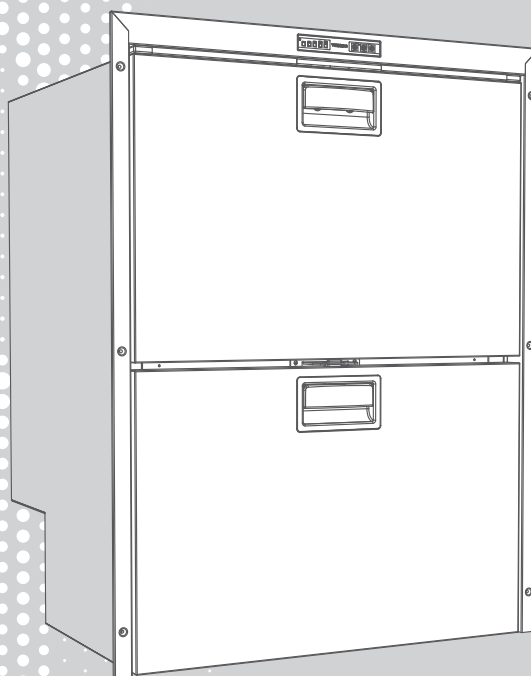

THANK YOU FOR PURCHASING A VITRIFRIGO PRODUCT

Index

1. INTRODUCTION	22
2. GENERAL WARNINGS	22
Destination of the product	23
Receipt	23
Installation	23
Maintenance and safety (all models)	24
Disposal	25
3. PURPOSE OF THE MANUAL	25
Identification of the manufacturer	25
4. TYPES AND DESCRIPTION OF THE APPLIANCE	26
5. INSTALLATION	28
Appliance recessing with ventilated condenser	29
Appliance recess, with ventilated remote motor	29
Appliance recess for campers, caravans and motor-homes	30
Fixing the appliance	30
6. ELECTRICAL CONNECTION	30
7. START-UP	32
8. FUNCTIONALITY AND ADJUSTMENT OF THE TEMPERATURE	33
9. EXTRAORDINARY MAINTENANCE AND ASSISTANCE	33
Cleaning the refrigerator	33
Defrosting the appliance	34
Removing the drawers	35
Replacing the LED light	35
Removing the stainless steel front panel (DW models)	35
Replacing the door panel (CDW models)	36
Removing the drip tray ("DT" versions only)	36
10. TROUBLESHOOTING GUIDE	37
ANNEXES	92

1. INTRODUCTION

Dear client:

Thank you for choosing one of our products. Vitrifrigo hopes that you will be completely satisfied with your purchase. This manual is considered an integral part of the refrigerator and must follow the sales path to the user.

It can be found on the Vitrifrigo website www.vitrifrigo.com.

Each refrigerator, before being shipped, is thoroughly checked and tested to ensure it operates correctly. For more information or for any clarification, please contact one of our service centres or any of our offices directly.

Vitri Alceste

Models

DW35RFL	DW70RFL	DW180RFI	DW360RFI
DW35BTL	DW70BTL	DW180DTI	DW360DTI
DW42RFL	DW75RFL	DW180BTI	DW360BTI
C42DWRFL	C75DWRFL	DW210RFI	C180RFL
DW51RFI	DW90RFI	DW210DTI	
C51DWRFI	C90DWRFI	DW210BTI	
DW62RFI	DW100RFL	DW250RFI	
C62DWRFI	DW100BTL	DW250BTI	

2. GENERAL WARNINGS

- The manual refers to the models of the DW and CDW series.
- For a full list of the models and their sizes refer to Annex 1.
- Read this manual carefully before using the refrigerator.

ATTENTION: (for versions with R600a isobutane refrigerant only): fire hazard.

The appliance contains inflammable gas.

ATTENTION: Keep ventilation openings in the appliance's casing or in the recess free from obstruction.



ATTENTION: Do not use mechanical devices or other means other than those recommended by the manufacturer to accelerate the defrosting process.

ATTENTION: Do not damage the refrigerant circuit

ATTENTION: Do not use electrical appliances or devices inside the food storage compartments if these appliances or devices are not of the type recommended by the manufacturer.

Destination of the product:

- This appliance is designed for use in applications such as:
 - kitchen areas for personnel in shops, offices and other work environments;
 - By customers of farms, hotels, motels and in other residential environments;
 - Bed and Breakfast establishments;
 - In catering services and similar applications but not for retail purposes.
 - In camper vans, caravans and on pleasure craft
- Whenever this refrigerator should replace an old type, it is recommended to make any lock unusable before scraping it.
- This appliance may only be used with recessed installation.
- Respect the indications of the key present on the cover (letters I / L present in the model code) for correct installation of the appliance.
- Follow the installation instructions given in this manual carefully.
- It is absolutely prohibited to use the refrigerator for any use other than those intended.
- This appliance is not designed for direct contact with food
- The appliance may be used by children aged 8 and older and by people with reduced physical, sensory or mental abilities, and by people lacking experience or the necessary knowledge, provided that use is supervised or done after suitable instruction has been given regarding the safe use of the appliance and once there is an understanding of the danger inherent in the product and its use.
- Children must not play with the appliance.
- Cleaning and maintenance by the user must not be done by children without the proper supervision.

Receipt:

- The refrigerator must only be installed by qualified staff
- Check that the packaging is intact. If not, report it to the courier.
- Remove the refrigerator from the packaging, working with maximum care; in order to prevent accidental injury the use of safety gloves is advised.
- Check that the product has not been damaged.
Any damage must be reported to the reseller within 24 hours of taking delivery of the appliance.

Installation:

- Install the product, taking the utmost care and caution to avoid accidentally damaging the product. Use protective gloves.
- Before connecting the refrigerator, check that the network voltage corresponds with

that displayed on the equipment's identification label, or with that indicated on the label on the compressor.

- Once installation has been completed, check that the refrigerator is not resting on a power cable.
- If the power supply cable is damaged it must immediately be replaced by the technical assistance service or by qualified personnel.
- Place the refrigerator away from heat sources, making sure that there is sufficient ventilation
- We recommend that you wait at least one hour before switching the refrigerator on, in order to allow the refrigeration circuit to be completely efficient.
- We recommend leaving sufficient space to be able to disconnect the appliance from the power supply, should the need arise.
- DW and CDW series refrigerators must be used with recessed installation

ATTENTION: To avoid any hazard caused by the appliance being unstable, it must be fixed according to the instructions.

Maintenance and safety (all models):

- Maintenance of the refrigerator must be only be carried out by qualified staff
- Before performing any maintenance or cleaning operation, unplug or switch off the appliance.
- Keep ventilation openings free from obstructions.
- Contact a suitably qualified person to clean the ventilated condenser.
- Always carry out the inspections, checks, and scheduled maintenance described in this manual.
- Do not attempt to remove, modify or repair the refrigerator.
- For any operational problems contact the Vitrifrigo Service Centre closest to you; in any case, request the assistance of a suitably qualified person.
- Do not store explosive substances in this appliance such as aerosol cans with flammable propellant.
- The appliance must not be cleaned with a jet of water.
- For appliances intended to be used at altitudes higher than 2000 m, contact the manufacturer.
- The environment in which the appliance is installed must be adequately ventilated if possible.
- If the environment, in which an appliance containing a flammable refrigerant is used, is not ventilated, the environment must ensure that, should any gas leak, it cannot reach a concentration such as to cause a fire or explosion as a result of a heat source

(electric heating appliances or similar).

Disposal:

- Do not throw the packaging used for your appliance away. Separate the materials according to local waste disposal regulations.
- This product must not be disposed of with municipal waste but must be disposed of separately.
Contact your nearest Waste Electrical and Electronic Equipment (WEEE) collection centre or take it to a retailer when purchasing a new, equivalent appliance.
- The symbol to the side indicates that the refrigerator must not be disposed of as urban waste.
- Improper disposal or incorrect use of the refrigerator is subject to administrative and/or penalties imposed by current legislation.



3. PURPOSE OF THE MANUAL

This manual, referring to DW and CDW series refrigerators, is intended as a guide to the appliance's proper use and maintenance.

In order to learn how to operate and use the refrigerator, you must read this manual carefully.

This manual contains the operations related to: installation, operation, maintenance.

The refrigerator has been manufactured to comply with all the safety requirements given by legislation and regulations. Nevertheless, the user's utmost safety depends on carefully reading this manual and on regular and careful cleaning and maintenance.

Some information or diagrams in this manual may show details or particular aspects that might differ slightly from the refrigerator that you have purchased. The essential information, however, remains the same. Depending on the constant improvement of models, this refrigerator may show variations that are not covered in this manual.

Any modifications will appear, depending on the need, in future versions of the manual.

Identification of the manufacturer:

The refrigerator has been designed and manufactured exclusively by:

Vitrifrigo s.r.l.

Via Mazzini 75 - fraz. Montecchio - 61022 VALLEFOGLIA(PU) - Italia

tel. +39 0721 154500 - fax. +39 0721 497739

e-mail info@vitrifrigo.com - www.vitrifrigo.com

4. TYPES AND DESCRIPTION OF THE APPLIANCE

DW	Single drawer	DW35RFL, DW42RFL, DW51RFI, DW62RFI, DW70RFL, DW75RFL, DW90RFI, DW100RFL	RF	Fridge
		DW35BTL, DW70BTL, DW100BTL	BT	Freezer
	Double drawer	DW180RFI, DW210RFI	RF	Fridge
		DW180BTI, DW210BTI	BT	Freezer
		DW180DTI, DW210DTI	DT	Fridge - Freezer
		DW250RFI, DW360RFI, C180	RF	Fridge
		DW250BTI, DW360BTI	BT	Freezer
		DW360DTI	DT	Fridge - Freezer
	Single drawer	C42DWRFL, C51DWRFI, C62DWRF, C75DWRFL, C90DWRFI	RF	Fridge

The label showing the serial number and the technical data is placed inside the refrigerator. The first four digits of the serial number identify the year and the week of manufacture.

Description of the appliance - DW series (Double drawer)

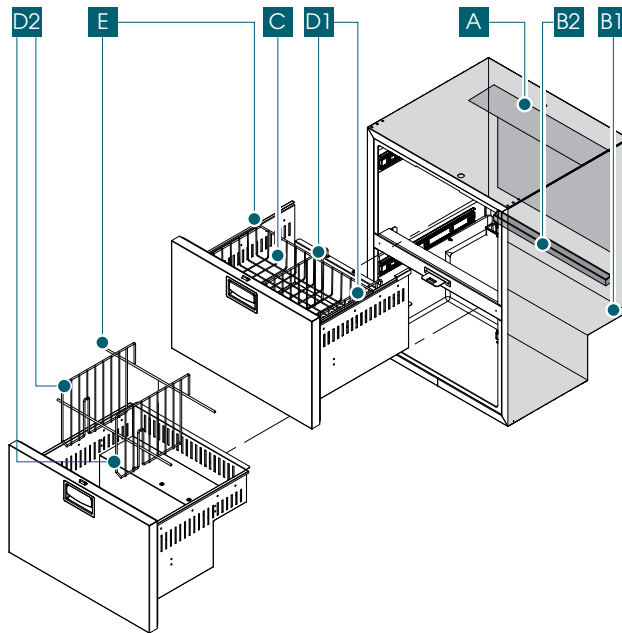

A) Evaporator
B1) Drip tray (RF version)
B2) Divider (DT version)
C) Wire basket
D1) Drawer dividers (top)
D2) Drawer dividers (bottom)
E) Bottle holder

Description of the appliance - DW series (Single drawer)

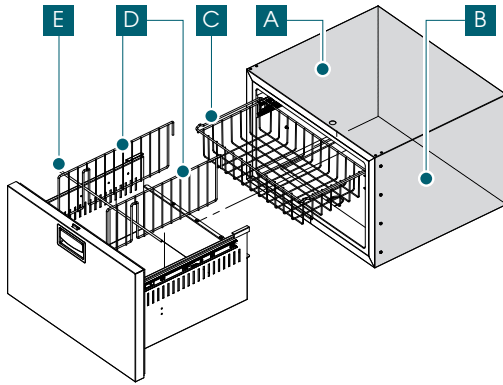

- | |
|---------------------------|
| A) Evaporator |
| B) Drip tray (RF version) |
| C) Wire basket |
| D) Drawer dividers |
| E) Bottle holder |

Description of the appliance - DW series (Combined)

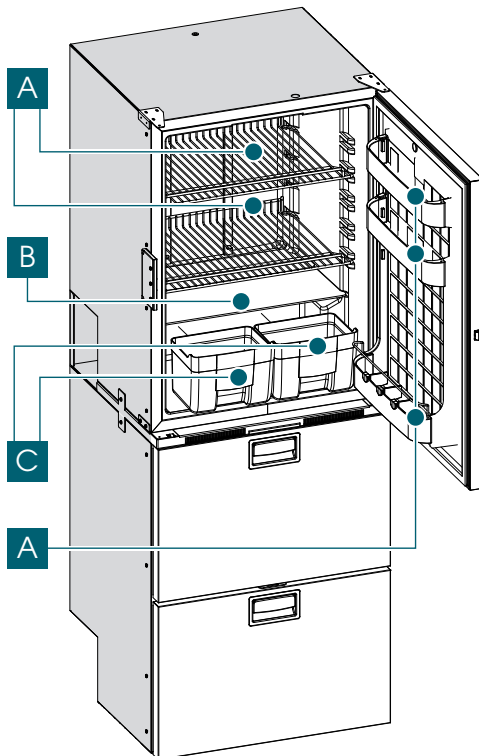

The lower part consists of a single drawer or a double drawer of the DW series

- | |
|---------------------------|
| A) Removable grilles |
| B) Removable glass shelf |
| C) Fruit basket |
| D) Removable door shelves |

Description of the appliance - CDW series (Single drawer)

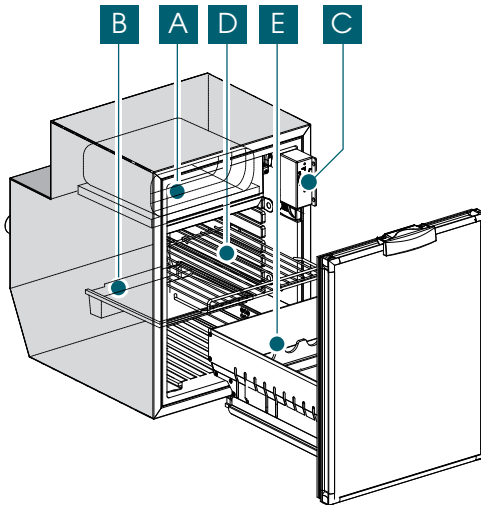

A) Evaporator
B) Drip tray
C) Thermostat box
D) Removable grilles
D) Drawer divider

5. INSTALLATION

Installation key:

the presence of the letters I and L in the model code indicate the version relative to the type of installation envisioned

I = version with internal motor for recessing

L = version with remote motor for recessing

(E.g. DW35RFL = DW35 model code L letter for recessed version)

Ensure that the refrigerator is not damaged when opening the packaging after receiving the product. Any transportation damage must be reported promptly to the reseller and, in any case, within 24 hours of taking delivery of the appliance. Handle the product with the utmost care and attention. When positioning the refrigerant unit (in refrigerator models with a remote refrigerant system), take precautions to avoid obstructions and breaking the connection pipes. Always position the refrigerator and the remote refrigerant unit (in the versions with such a solution) on a horizontal surface that can support the weight of the appliance and its eventual contents. Once installation has been completed, check that the refrigerator is not resting on a power cable. If the power cable is damaged, it must be replaced immediately by someone from the technical service centre or by someone suitably qualified, in order to avoid any risk. Place the refrigerator away from heat sources ensuring that it has enough ventilation as in the following installation examples.

Once the refrigerator has been positioned, wait at least one hour before switching it on.

Appliance recessing with ventilated condenser

The size of the front opening to be prepared for recessing the appliance must respect the dimensions of the refrigerator (see Annex 1). The recess must respect the minimum distances between the appliance and the surrounding structure and it must have suitable ventilation openings communicating directly with the open space in the room, in order to obtain correct air circulation by means of the chimney effect, as indicated in Annex 2 - Fig.1.

The recess must ensure that all possible live parts of the appliance are not directly accessible as well as the ventilation openings, by fitting them with suitable grilles. The grilles must have openings with max. dimension of 5 mm.

The envisioned ventilation openings are:

1. with dimension no less than 120 mm in height for the dimension of the refrigeration in width if positioned behind, which must always be associated to another opening of at least 120x120 mm positioned on the side of the condenser (Annex 2 - Fig.1).
2. of dimensions 120x120mm if positioned on both sides, as indicated in Annex 2 - Fig.1

The minimum distances between the various parts of the appliance and the recess structure must not be less than 75mm. (Annex 2 - Fig.1)

For recess situations in compartments in which the minimum distance of 75mm is only respected at the rear of the appliance, you must provide for ventilation openings on the same side, respecting the instructions for their placement, their number and their dimensions as shown in Annex 2 - Fig.1. For recess situations with the presence of shelves in contact with the upper and lower parts of the appliance, make the ventilation openings above and below the appliance as indicated in Annex 2 - Fig.1

In all the situations of the described ventilation openings, only the minimum distance of 75mm from the sides of the appliance may not be observed.

Appliance recess, with ventilated remote motor

The size of the front opening to be prepared for recessing the appliance must respect the dimensions of the refrigerator (see annex 1).

The recess must respect the minimum distances between the remote motor and the surrounding structure and it must have suitable ventilation openings communicating directly with the open space in the room, in order to obtain correct air circulation by means of the chimney effect, as indicated in Annex 2 - Fig.2

The recess must ensure that all possible live parts of the appliance are not directly accessible as well as the ventilation openings, by fitting them with suitable grilles. The grilles must have openings with max. dimension of 5 mm.

The ventilation openings must have dimensions no smaller than 120x120 mm and positioned on both sides, as indicated in Annex 2 - Fig.2.

Appliance recess for campers, caravans and motor-homes.

To install the refrigerator or fridge units in a caravan, camper van, motor home etc. make the recess space in the vehicle with ventilation vents directly on the outside, fitted with suitable grilles to ensure that all possible live parts of the appliance are not directly accessible (thermostat, control unit and fan). The grilles must have openings with max. dimensions 5 mm and be on at least one side (see annex 2 Fig. 1-2).



ATTENTION

Keep ventilation openings free from obstructions in the recess. Do not place any objects or other materials near the ventilation grilles, nor cover or block them.

Fixing the appliance.

To secure the appliance in the recess space, use the holes on the fixing profile or, if present, the fastening elements inside the housing.

6. ELECTRICAL CONNECTION

ATTENTION (only for models with alternating current): The operator must be able to disconnect the appliance from the mains electricity.

Therefore, make sure that there is an access point to the electrical power supply near the appliance and/or that the system is equipped with a 6A omnipolar circuit breaker with a contact opening of at least 3mm and a minimum differential sensitivity of 0.03A.

Before connecting the product, make sure that the voltage corresponds to that shown on the identification label or that shown on the label on the compressor.

IMPORTANT: by law, the appliance must be earthed.

Make sure that the earthing system for the electrical network is working perfectly.

We accept no responsibility whatsoever for any injury to people or damage to property deriving from the failure to properly comply with this regulation.

The use of adaptors, multiple sockets and extension cords is not recommended.

In the event that the appliance's plug and the socket are not compatible, replace the plug with a suitable one.

This operation must be done by a suitably qualified person who must ensure that the cable section of the plug is appropriate to the power absorbed by the appliance.

Do not interconnect any other type of appliance to the refrigerator.

Electrical connection for models 12/24Vdc and 12/24Vdc/100-240 Vac 50/60Hz

It is recommended to connect the 12Vdc or 24Vdc power supply line directly to the

battery by following the corresponding instructions of the supplied control unit (see annex 4).

Prepare the alternating current power supply line using three-pole cable with minimum section per wire of 1 mm² and suitable isolation for the methods and environment of use and compliant with the regulations in force.

Make the connection to the AC power line by means of a socket-plug connection of adequate capacity in accordance with current regulations or provide a 6A omnipolar circuit breaker with a contact opening of at least 3 mm and a minimum differential sensitivity of 0.03A, or in any case in accordance with current regulations.

Once installation has been completed, check the continuity of the earth circuit and carry out all the electrical safety tests provided for by current regulations. Protect and lock the cables in order to prevent accidental pulling of the cable from disconnecting it from the connections or coming into contact with hot parts with a temperature above 50°C or with sharp parts.

It is recommended that the installation of the power supply lines is carried out by qualified personnel who will check the compliance of the unit with the regulations in force and issue the relative certifications of conformity.

STANDARD BATTERY PROTECTION SETTINGS

12 V cut- out V	12 V cut- in V	24 V cut- out V	24 V cut- in V
12 V cut- out V	12 V cut- in V	24 V cut- out V	24 V cut- in V
10.4	11.7	22.8	24.2



CABLE DIMENSIONS: CONNECTION BETWEEN THE BATTERY AND ELECTRONIC UNIT

Section (mm ²)	2.5	4	6	10
Max. length m line at 12V (m)	2.5	4	6	10
Max. length m line at 24V (m)	5	8	12	20

7. START-UP (ELECTRONIC THERMOSTAT)

The electronic thermostat features two button controls (Fig. 7.1):



- The stand-by command “”
 - The temperature adjustment command “”
- After connecting the refrigerator to the power supply, press the key “” on the membrane thermostat (Fig. 7.1) to alternately switch the appliance on or put it in stand-by.

7. START-UP (MECHANICAL THERMOSTAT)

Once the plug is connected to the power outlet, the fridge will start-up automatically in thermostat mode and no further operations are required for its correct operations.

For a reasonable arrangement and storage of food follow the table below:

Food	Preservation time	Method of preservation	Position in fridge
Clean meat and finish	2 or 3 days	Exclusively wrapped or closed in hermetic containers and introduced after cooling, if previously heated	On the grille/shelf under the freezer area.
Eggs	1 month		Use the door compartments.
Butter or margarine	1 week		Use the door compartments.
Cooked foods, cakes and soups	3 or 4 days		On the grille in the lowest part of the refrigerator.
Cold cuts, fresh pasta, creams, puddings, chocolate, pastries, animal fats	3 or 4 days		On any grille/shelf.
Water and beverages			Use the door compartments.
Fruit and vegetables			In the vegetable drawer, in the lower part of the refrigerator.

8. FUNCTIONALITY AND ADJUSTMENT OF THE TEMPERATURE

ELECTRONIC THERMOSTAT

To set the desired temperature, press the key “” on the thermostat (Fig. 7.1). Each time it is pressed, the light indicator goes from left to right.

When the indicator is on the left, the appliance is on minimum (warmest temperature). To select a colder temperature, press the control repeatedly until the rightmost light indicator turns on (coldest temperature); when it is pressed again, the leftmost light indicator turns on. When the indicator is in the centre, the appliance is at a medium temperature.

MECHANICAL THERMOSTAT

If the appliance is equipped with a mechanical thermostat for automatic temperature maintenance and automatic defrost, bear in mind that the refrigerator is already set to the optimum operating temperature.

To regulate the temperature, turn the knob positioned inside the fridge, in a clockwise direction (towards “MAX”) in order to lower the temperature, and in an anti-clockwise direction (towards “MIN”) to increase it.

9. EXTRAORDINARY MAINTENANCE AND ASSISTANCE

Cleaning the refrigerator:

Before starting to clean the refrigerator, make sure it is not connected to the mains electricity. If connected, unplug the appliance from the electrical supply.

OUTSIDE

wash the outside of the refrigerator with lukewarm water, rinse with cold water and dry with a soft cloth. Do not use abrasive or aggressive products.

Cleaning and maintenance of the condenser must be performed only by authorised after-sales staff.

INSIDE

Remove the internal shelves, the grilles (or the basket) and the containers and clean using lukewarm water with the addition of baking soda or vinegar.

Rinse and dry carefully with a soft cloth.

Completely avoid the use of abrasive products, detergents or soaps. in order to avoid the formation of mould or unpleasant smells, unplug the appliance, empty it and clean the inside and leave the door half open.

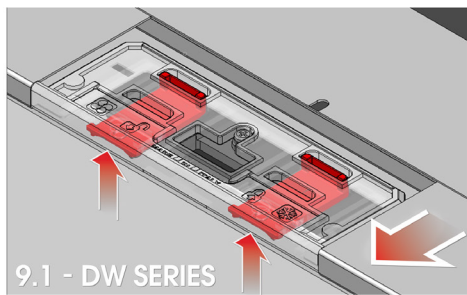

9.1 - DW SERIES



9.2 - CDW SERIES

If the refrigerator will not be used for a long time, disconnect it from the electrical power supply, empty it out completely, clean it and leave the door in the “Vent Position”.

To put the door in the “Vent Position”, press the two buttons with both fingers and remove the mechanism from the upper bracket in DW models (Fig. 9.1), move the central hinge pin inwards in CDW models (Fig. 9.2).

To reposition the drawer in operating mode, press the two buttons again and slide the mechanism back to its original position.

Defrosting the appliance:

It will be necessary to defrost the refrigerator every so often when the frost builds up to a thickness of more than three millimetres. This operation is necessary in order to guarantee that the fridge works efficiently and to avoid increasing the electricity consumption.

To defrost the appliance completely, press the stand-by control “” in models with an electronic thermostat or turn the knob to the stop position in models with a mechanical thermostat to put the product in stand-by. Keep the drawers open to accelerate defrosting times

ATTENTION: Do not use mechanical devices or other means other than those recommended by the manufacturer to accelerate the defrosting process

ATTENTION: Do not remove the layer of frost using pointed or sharp metal tools that may cause a puncture in the cooling plate with irreparable consequences for the appliance.

When the defrosting is complete, start up the refrigerator by pressing the button “” or turn the thermostat knob back to the desired position.

Removing the drawers (Lateral guides)

To remove the drawers from the sliding guides, press on the two levers, right and left, in the guides (Annex 5 - Fig.1).

Removing the drawers (Lower guides)

To remove the drawers from the sliding guides, press on the two orange mechanisms at the bottom of the drawer and then lift it (Annex 5 - Fig.2).

Replacing the LED light

ATTENTION: Replacing the LED light must be done by a suitably qualified person who is able to adopt all the appropriate safety measures.

Before replacing the light, make sure that the refrigerator is not connected to any electrical supply. If connected, unplug the appliance from the electrical supply.

ATTENTION: When replacing it, do not damage the magnetic control reed.

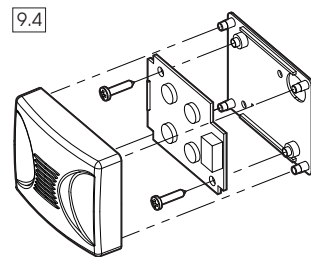
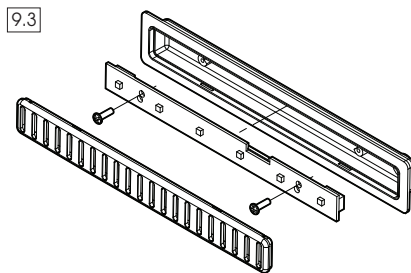

To replace the LED light board, in both types of board (Fig. 9.3 & Fig. 9.4), proceed as follows:

1. Remove, perpendicular to the base, the protective cover, being careful not to damage the fixing pins.
2. Disconnect the light's power cables.
3. Replace the LED light profile.
4. Connect the power source.
5. Reposition the protective cover.

Removing the stainless steel front panel (DW models)

Remove the drawer from the guides to remove the stainless steel front panel (Annex 5 - Fig.1). Then follow the instructions in Annex 6 to remove the stainless steel front panel.

Replacing the door panel (CDW models)

Remove the drawer from the guides to remove the stainless steel front panel (Annex 5 - Fig.2). Then follow the instructions in Annex 6 to remove the door panel.

Removing the drip tray ("DT" versions only)

Proceed as follows to extract the drip tray:

1. Disconnect the water drain pipe
2. Remove the fixing screws from the inside (Fig. 9.5)
3. Pull the drip tray downwards to release the fastening element on the bottom of the tank (Fig. 9.6)

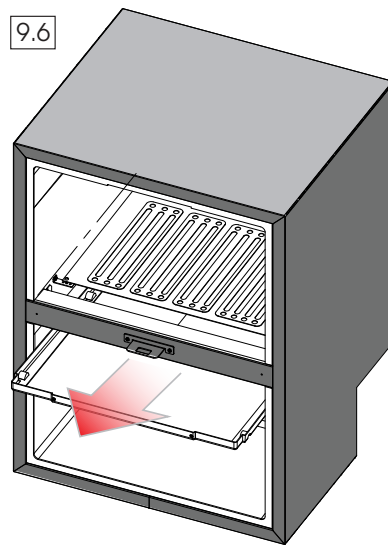
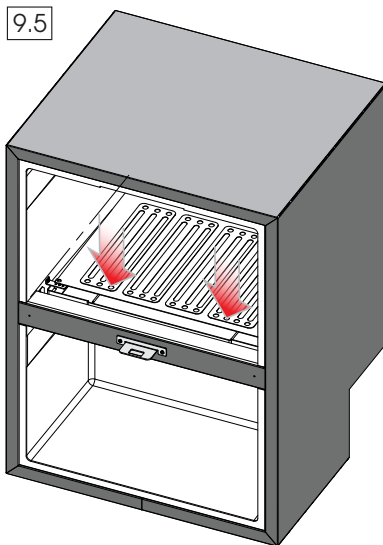

10. TROUBLESHOOTING GUIDE

What to do if the fridge doesn't work:

Problem	Cause	Solution
The refrigerator does not start	No electrical current	Check that the power supply cable is intact and properly connected.
		Mod. in direct current. Check that the battery is charged
		check that the voltage on the terminal board of the appliance electronic device is equal to that of the battery.
	Try running a reset	Disconnect the power cable. Wait for a minute and then reconnect it. Try switching the unit on again.
	Thermostat in "Off" position	Move the thermostat to the recommended position
The refrigerator does not cool	Insufficient output	Check that: the door closes hermetically, that the fridge is not near to heat sources and is sufficiently ventilated, that the condenser is not clogged with dust
The refrigerator does not stop	The internal temperature is too high	Check that the drawers close tightly
	Try running a reset	Disconnect the power cable. Wait for a minute and then reconnect it. Try switching the unit on again.
The courtesy light does not switch on	The door has been left open for too long	Close and re-open the door. Check the correct switch-on of the courtesy light
	The light is faulty	Call the service centre
The refrigerator is noisy		Check that the refrigerator sits flat and is not in direct contact with any object that might cause vibrations

If you do not manage to achieve regular operation after these checks, contact the customer assistance service.