

IS 8.05 - IS 9.06

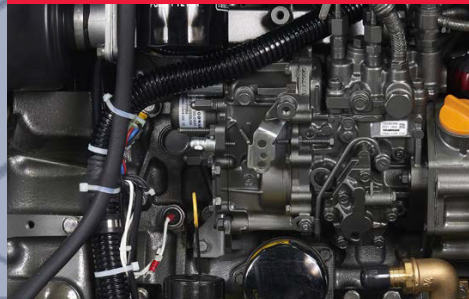

CONTROL PANEL



YANMAR ENGINE



INPUT/OUTPUT FUEL PIPE

the intercooler W/A assures the perfect functioning of the generator independently of the external ambient temperature, therefore the alternator and the engine will work at ideal temperature optimizing the performance and reliability of the gen-set. The generator may be installed in any room on the vessel without the need of ventilation blowers. Extremely compact and quiet, the generator is equipped with a double shock absorbing system to increase comfort: the first one absorbs vibrations from engine-alternator to the frame, the second one absorbs residual micro-vibrations from frame to vessel.

We reserve the right to modify the data, images and drawings in this document without prior notice.

For more detailed information, please contact your local distributor or Mase Generators S.p.A.



COMPACT DESIGN



EASY INSTALLATION



SUPER SILENCED



mase generators spa

Via Tortona, 345 | 47522 - Cesena (FC) | Italy

Tel. +39 0547 354311

commercial@masegenerators.com

www.masegenerators.com

mase
GENERATORS
Believing in change.

Output power 8 kW 50 Hz - 9 kW 60 Hz

CONTROL PANEL

_ CBU EVO IL4 device controls and drives the genset. The large display and control pushbuttons allow an easy use and monitoring:

- Manual start
- Voltage Vac
- Frequency Hz
- Hour meter
- Genset Battery voltage
- Low oil pressure alarm
- Engine preheating
- Engine high temperature alarm
- Alternator battery charger failure alarm
- Protection alarm for frequency and rpm
- Alarm history
- Maintenance warning
- General alarm outlet
- RUN outlet
- Ready outlet
- Programmable AUX outlet

_ Emergency stop button

_ Magneto-thermal protection

ENGINE

_ Easy maintenance access to the feeding and lubrication systems, the sea water pump and the air filter

_ Double vibration dumping system

_ Oil drain pump

SOUNDPROOF CABIN

_ Made of extremely light marine aluminum with very high resistance to external agents

Insulated poles kit (for metal hull boats), dry exhaust kit and keel cooling kit are available on request

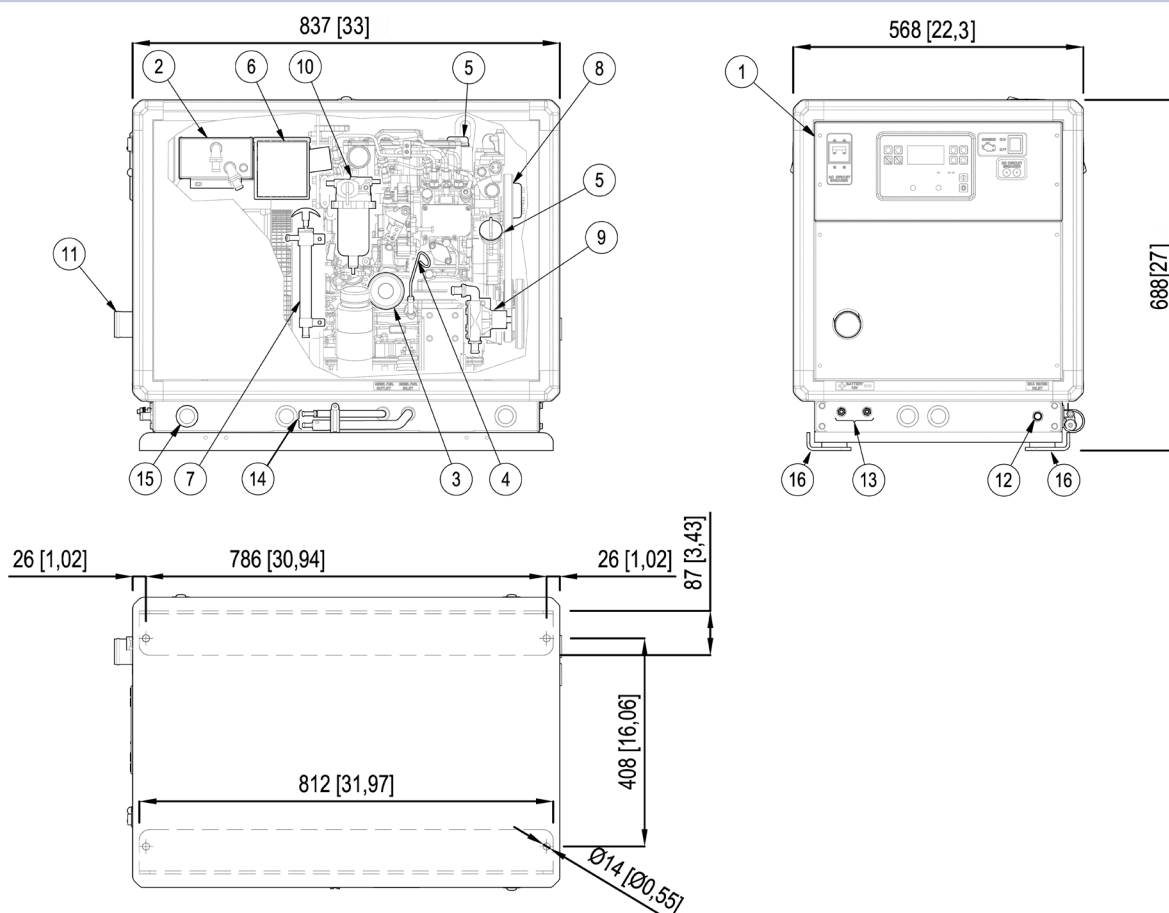

- | | | | |
|--------------------------|---------------------|--------------------------------|------------------------------------|
| 1. Control panel | 6. Air filter | 11. Exhaust manifold (d.50 mm) | 14. Fuel tank connections (d.8 mm) |
| 2. Air / water exchanger | 7. Oil drump pump | 12. Sea water intake (d.16 mm) | 15. Cables outlet |
| 3. Oil filter cartridge | 8. Fresh water pump | 13. Battery connections | 16. Genset fixing brackets |
| 4. Oil dipstick | 9. Sea water pump | | |
| 5. Engine oil filler | 10. Fuel filter | | |

IS 8.05

IS 9.06

mase
GENERATORS
Believing in change.

Output power 8 kW 50 Hz - 9 kW 60 Hz
50 Hz**60 Hz**  

AC alternator -

Synchronous, 4 poles, brushless, self-energized, with AVR

Cooling -

Air / Water (Intercooler W / A)

Voltage -

115 or 230 V

120 or 240 V

Frequency -

50 Hz

60 Hz

Amps -

69.6 or 34.8 A

75 or 37.1 A

Max power -

8 kW

9 kW

Continuous power -

7.3 kW

8.2 kW

Power Factor -

cos ϕ 1

Insulating class -

H

Voltage stability -

 $\pm 2\%$

Frequency stability -

 $\pm 5\%$

The power is referred to a sea water temperature up to 31°, an atmospheric pressure of 100 KPa and a humidity percentage of 30%

Model -

Yanmar 3TNV80F

Type -

Diesel 4 stroke

Cylinders -

nr 3

Cylinder block material -

Cast iron

Bore -

80 mm - 3.15 in

Stroke -

84 mm - 3.31 in

Displacement -

1267 cc - 77.32 CID

Power -

12.74 hp - 9.37 kWm (at 1500 RPM)

14.35 hp - 10.56 kWm (at 1800 RPM)

RPM -

1500

1800

Compression ratio -

23:1

Combustion system -

Direct injection

Engine head material -

Cast iron

Speed governor -

Centrifugal mechanical

Lubrication system -

Forced

Oil sump capacity with filter -

3 l - 0.85 gl

Engine stop system -

Solenoid valve

Fuel pump -

Electric

Max. fuel pump head -

700 mm - 27.5 in

Fuel consumption -

2.3 l/h - 0.61 gl/h

2.9 l/h - 0.77 gl/h

Air intake -

790 l/min - 28 cfm

904 l/min - 32 cfm

Starting battery -

65 Ah - 12 V

Battery charger -

40 Ah - 12 V

Starter motor -

1.2 kW - 12 V

Max. inclination -

25°

Water pump flow -

25 l/min - 6.6 gl/min

28 l/min - 6.1 gl/min

Sea water inlet pipe \varnothing -

16 mm - 5/8"

Exhaust pipe \varnothing -

50 mm - 2"

Input/Output fuel pipe \varnothing -

8 mm - 16/8"

Dimensions (L x W x H) -

837 x 568 x 688 mm - 33 x 22 x 27 in (with soundproof box)

Weight -

295 Kg - 650 lb (with soundproof box)

Noise Level -

49 dBA at 7 mt (23 ft)

51 dBA at 7 mt (23 ft)

Accessory

Code

ACCESSORIES ON REQUEST

• Installation kit D.50: filtering set, exhaust set and siphon break D.16	012276
• Filtering kit: sea water inlet, sea water strainer, taps, fittings D.16 - ref.5	04349
• Exhaust kit: muffler, silencer, exhaust outlet D.50 MASE - ref.3	04658
• Super silenced exhaust kit & exhaust gas separator D.50 MASE - ref.6	010078
• Siphon break D.16 - ref.4	04290
• Mase Muffler D.50	70795
• Silencer Mase D.50	71809
• Mase water/gas exhaust separator D.50	04488
• Vetus LP50 muffler	71148
• Vetus silencer MP50	71751
• Silencer c.71751 with soundproofing sponge	039866
• Vetus Separator LGS5038	71717
• Centek muffler 2" - ref.7	71155
• Centek 2" water/gas exhaust separator - ref.8	71156
• Remote START/STOP 20-meter control kit for CBU (3000 RPM) - ref.1	037561
• Comap IL4 remote start panel with 20-meter cable - ref.2	039607
• Cruise KIT	913831



.1



.2



.3



.4

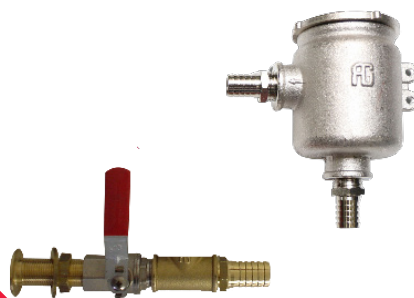

.5



.6



.7



.8