



CBU control panel (Mod-Bus transmission Unit)

New design, latest technology, big display and soft touch buttons for quick menu navigation, start and stop procedure, IP54 protection grade. Very compact 86x124mm (3.84x4.9 in) with a shielded connecting cable 10mts (32.8 ft) long, CBU has many functions for an easy monitoring of the generator:

- ON/OFF/START/STOP/MENU controls.
- Digital hour-meter, Main voltage, Generator Battery voltage, external battery pack voltage, Frequency, Service time, Event list of last 10 alarms and time.
- 13 different alarms icons displayed.
- 485 Mod-Bus connector for monitoring generator by boat main control monitor.

Engine

- Easy access in case of maintenance of feeding system, lubrication system, sea/water pump and air filter.
- Safety stop in case of low oil pressure.
- Safety stop in case high engine temperature or exhaust gas temperature.
- Double vibration dumping system.
- Oil filter and fuel filter easy to replace.
- Oil drain pump provided.

Alternator

- Synchronous, 2 poles, self-regulated, brush less self-excited.
- Rotor and stator epoxy resin coated against external agents.
- Rotor dynamically balanced.
- Insulation class H.
- Safety stop for high coils temperature.

Soundproof cabin

The structure is composed by an aluminum mainframe and painted panels of aluminum 5754 type, that has a very high resistance to external agents.

Thanks to this structure, soundproof cabin has a limited weight and an easy accessibility in case of maintenance services, also if installed in narrow places.

The Intercooler System w/a

Assures the perfect functioning of the generator independently by the external ambient temperature, therefore the alternator and the engine will work at ideal temperature optimizing the performance and reliability of the gen-set.

Engine	50 Hz	60Hz
Model	Yanmar L70N	Yanmar L70V
Type	Diesel, 4-stroke	
Cylinders (nr.)	1	
Cylinder block material	Aluminium	
Bore (mm. - in.)	78 - 3	
Stroke (mm. - in.)	67 - 2.64	
Displacement (cc. - CID)	320 - 19,5	
Power (hp)	6.1	6.7
RPM	3000	3600
Compression ratio	20:1	
Combustion system	Direct injection	
Engine head material	Aluminium	
Speed governor	Centrifugal mechanical	
Lubrication system	Forced	
Oil sump capacity with filter (lt. - US qts)	1.1 - 0.24	
Engine stop system	Fuel solenoid	
Fuel pump	Electric	
Fuel pump discharge (cm. - ft)	70 - 2.3	
Fuel consumption (l/h-gl./h)	1.3 - 0.28	1.5 - 0.33
Air intake (l/min. - gl/min.)	400 - 14	480 - 16.9
Starting battery (Ah-V)	45 - 12	
Starter (kW-V)	0.8 - 12	
Max. inclination	30°	
Water pump flow (l/min. - gl/min.)	20 - 4.4	

Alternator	50 Hz	60Hz
Type	Brushless synchronous 2-poles, self-excited	
Cooling	Air/water (Intercooler W/A)	
Voltage (V)	115 - 230	120 - 240
Frequency (Hz)	50	60
Amps	26 - 13	26.6 - 13.3
Max. power (kW)	3	3.2
Continuous power (kW)	2.7	2.9
Battery charging output (A-V)	10 - 12	
Power factor (cos ø)	1	
Insulating class	H	
Voltage stability	±10%	
Frequency stability	±5%	

Cooling system

The cooling system of the engine is based on a intercooler system heat exchanger (sea water/air) with the main function of reducing the temperature of the air flow inside the soundproof cabin. The system provides an efficient cooling of the alternator and the optimal temperature for the best performance and reliability of the gensets; despite the on board allocation and the room temperature.

	50 Hz	60Hz
Dimension (Lenght x Width x Height.)	590x406x515mm - 23.2x15.9x20.3 (in.) (with soundproof box)	
Weight	96 Kg. - 211 (lb) (with soundproof box)	
Noise Level	54 dB _A at 7mt (23 ft)	56 dB _A at 7mt (23 ft)

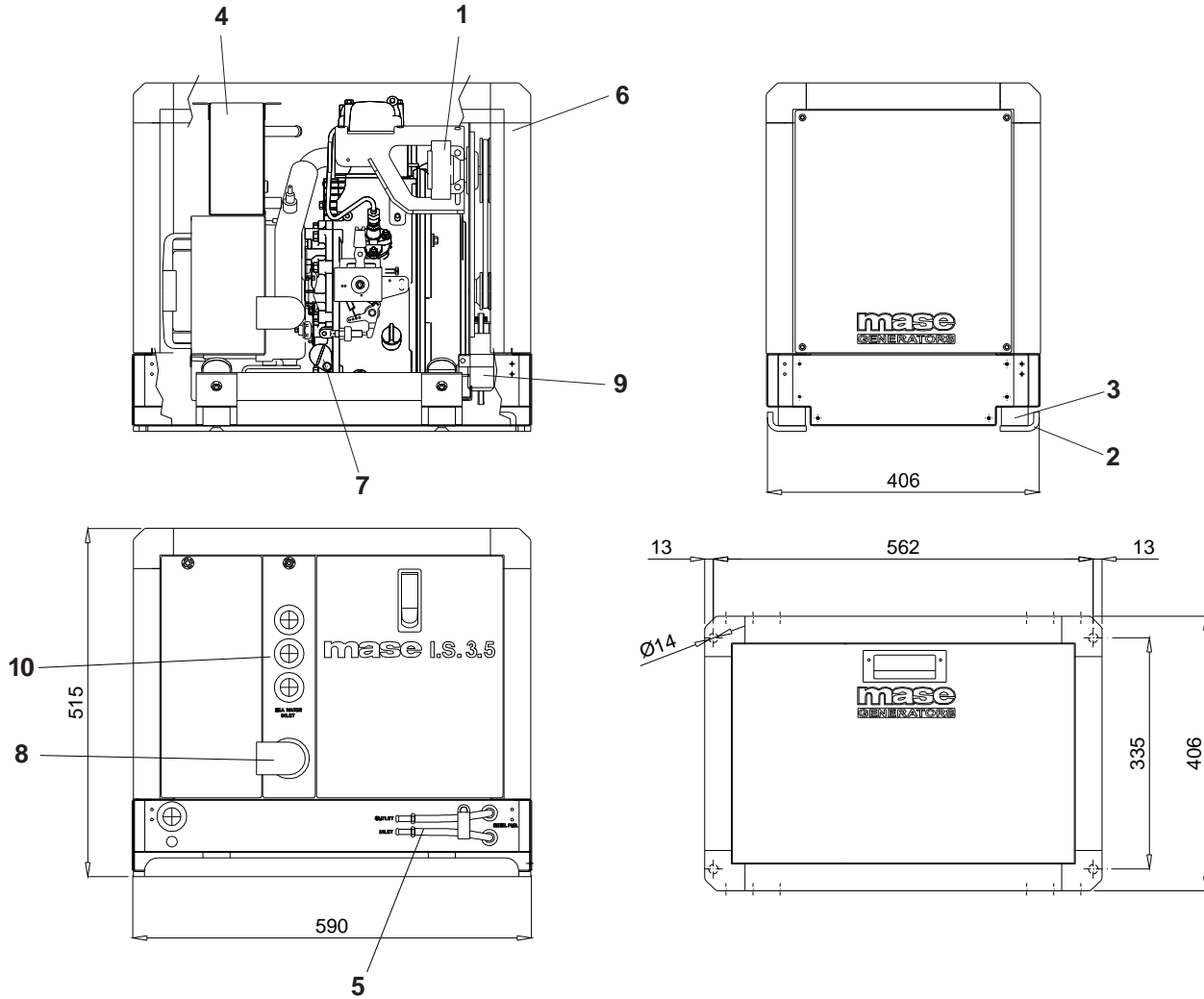

- 1- Sea water pump
- 2 - Genset base bracket
- 3 - Vibromounts
- 4 - Heat exchanger (Intercooler W/A)
- 5 - Fuel tank connection (ø1/4")
- 6 - Air cleaner
- 7 - Oil filter
- 8 - Exhaust manifold (ø2")
- 9 - Fuel pump (ø1/4")
- 10- Connection to sea water intake (ø1/2")

FITTINGS

- EXHAUST COMPONENTS KIT**
- SIPHON BREAK**
- W.G. SEPARATOR KIT**

*This drawing is only a reference and is not indicated for installation. For more information, you may contact your local dealer or **mase** generators S.p.A..*

***mase** generators S.p.A. reserves the right to change the design or specifications without notice and without any obligations or liability whatsoever. For more information, you may contact your local **mase** dealer.*

Dealer: