

### Remote Control Panel

Remote control panel was designed to include, in only one single panel, all switches, control devices and protection devices. Components are the following :

- Engine cut-off module for automatic stop in case of high water temperature, low oil pressure and high alternator temperature.
- Hour-meter.
- Start-stop button.
- Breaker for protection against overload and short circuit.
- Thermal switch for D.C. electric circuit.

### Engine

- Easy access for maintenance to feeding system, lubrication, sea/water pump and air filter.
- Easy access to Oil and fuel filters.
- Safety stop in case of low oil pressure.
- Safety stop in case of high water/exhaust gas temperature.

### Alternator

- Synchronous, 4 poles, self-excited, with AVR.
- Rotor and stator coated with epoxy resin against external agents.
- Rotor dynamically balanced.
- Insulation class H.

**MARINER**  
**1200 A**  
**11.2 kW**  
**50 Hz**

**MARINER**  
**1400 A**  
**13.5 kW**  
**60 Hz**

Engine	50 Hz	60Hz
Model	Yanmar 3TNV88	
Type	Diesel 4 stroke	
Cylinders (nr.)	3	
Cylinder block material	Cast iron	
Bore (mm. - in.)	88 - 3.46	
Stroke (mm. - in.)	90 - 3.54	
Displacement (cc. - CID)	1642 - 100	
Power (hp)	18.4	22.2
RPM	1500	1800
Combustion system	Direct	
Engine head material	Cast iron	
Speed governor	Centrifugal mechanical	
Lubrication system	Forced	
Oil sump capacity with filter (lt. - US qt)	6.7 - 7.1	
Engine stop system	Stop solenoid	
Fuel pump	Electric	
Fuel pump discharge (cm. - ft)	70 - 2.3	
Max fuel consumption (l/h-gal/h)	4 - 1.05	5 - 1.32
Starting battery (Ah-V)	80 - 12	
Battery charger (Ah-V)	40 - 12	
Starter (kW-V)	1,2 - 12	
Max. inclination	30°	
Water pump flow (l/min. - gal/min.)	25 - 6.6	28 - 7.4

Alternator	50 Hz	60Hz
Type	Synchronous, 4-poles, self-excited	
Cooling	Air	
Voltage (V)	115 - 230	120 - 240
Frequency (Hz)	50	60
Nominal current (A)	97.4 - 48.7	117.3 - 58.7
Max. power (kW)	11.2	13.5
Continuous power (kW)	10.2	12.3
Power factor ( cos Φ )	1	
Insulating class	H	
Voltage stability	±2%	
Frequency stability	±5%	

### Cooling system

The cooling of the engine is based on a closed inner flow of coolant. The system is based on a cupronickel heat exchanger seawater/coolant type, where the thermal exchange occurs between coolant and seawater. Two separate pumps contribute to the flow of the coolant and the sea water.

1200 A 50 Hz • 1400 A 60 Hz

**mase**  
GENERATORS

	50 Hz	60Hz
Dimensions (Length x Width x Height)	875 x 570 x 664 mm (34.4 - 22.4 - 26.14 in)	
Weight	294 kg (647 lb)	

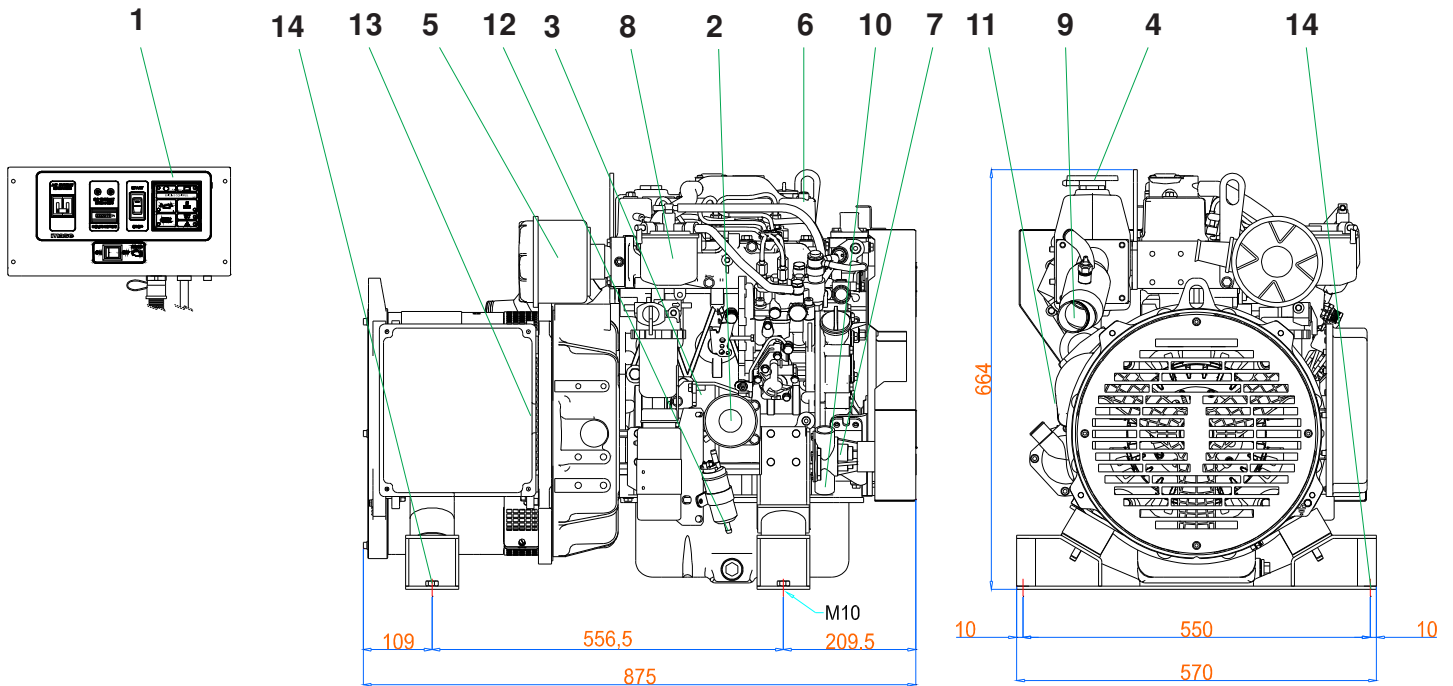

- |                                 |  |
|---------------------------------|--|
| 1 - Control panel               | 8 - Fuel filter                          |
| 2 - Engine oil filter cartridge | 9 - Seawater exhaust connection (ø 50mm) |
| 3 - Oil dipstick                | 10 - Seawater inlet (ø 16mm)             |
| 4 - Engine oil cap              | 11 - Battery connection                  |
| 5 - Air filter                  | 12 - Fuel tank connection (ø 8mm)        |
| 6 - Closed circuit water pump   | 13 - Electric cables outlet              |
| 7 - Seawater pump               | 14 - Fixing stirrups                     |

## FITTINGS

EXHAUST COMPONENTS KIT  
SIPHON BREAK  
WATER-GAS SEPARATOR KIT  
STARTING REMOTE CONTROL PANEL WITH INSTRUMENTS

*This drawing is only a reference and is not indicatly for the installation. For more information, you may contact your local dealer or **mase generators S.p.A.***

***mase generators S.p.A.** reserves the right to change the design or specifications without notice and without any obligations or liability whatsoever. For more information, you may contact your local **mase** dealer.*

Dealer:

**mase**  
GENERATORS

MASE GENERATORS S.p.A. Via Tortona, 345  
47522 Cesena (FC) Italy  
Tel. +39-0547-354311 Fax. +39-0547-317555  
Email : mase@masegenerators.com