

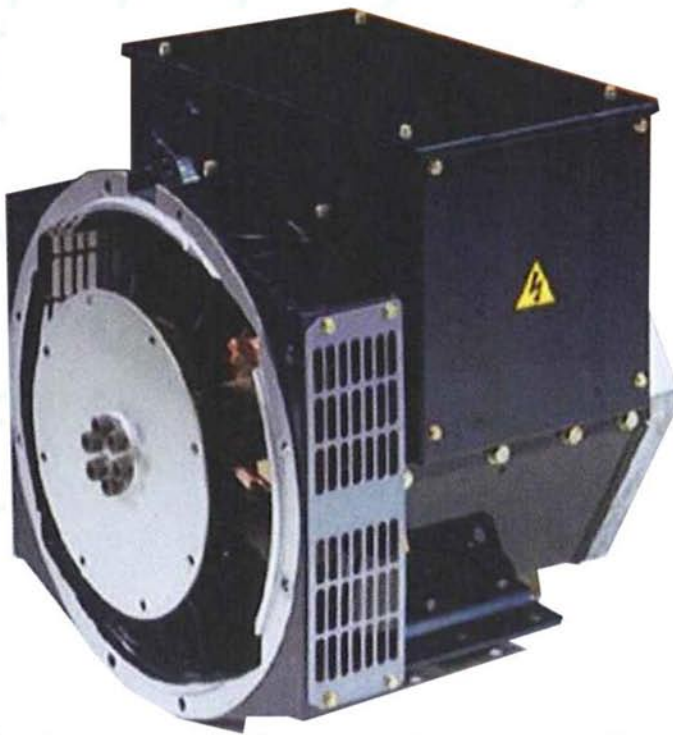

DG 164



DG164		3 Phase H insulation Industrial							
Voltage		50 Hz 1500rpm				60 Hz 1800rpm			
Series Star		380	400	415	440	416	440	460	480
Parallel Star		190	200	208	220	208	220	230	240
Series Delta		220	230	240	254	240	254	--	--
DG164A	KVA	8.1	8.1	8.1	6.2	9.6	10.2	10.2	10.2
	KW	6.5	6.5	6.5	5	7.7	8.2	8.2	8.2
	Efficiency (%)	75.6	76.2	76.6	77.1	75.8	76.3	76.9	77.4
	Power input (KW)	8.6	8.5	8.5	6.5	10.2	10.7	10.7	10.6
DG164B	KVA	11.0	11.0	11.0	8.4	13.0	13.8	13.8	13.8
	KW	8.8	8.8	8.8	6.7	10.4	11.0	11.0	11.0
	Efficiency (%)	78.8	79.4	79.8	80.2	79.0	79.4	80.0	80.5
	Power input (KW)	11.2	11.1	11.0	8.4	13.2	13.9	13.8	13.7
DG164C	KVA	13.5	13.5	13.5	11.0	16.0	16.9	16.9	16.9
	KW	10.8	10.8	10.8	8.8	12.8	13.5	13.5	13.5
	Efficiency (%)	80.0	80.7	81.0	81.5	80.3	80.7	81.3	81.7
	Power input (KW)	13.5	13.4	13.3	10.8	15.9	16.7	16.6	16.5
DG164D	KVA	16.0	16.0	16.0	13.5	18.9	20.0	20.0	20.0
	KW	12.8	12.8	12.8	10.8	15.1	16.0	16.0	16.0
	Efficiency (%)	81.0	81.6	81.9	82.4	81.2	81.7	82.2	82.7
	Power input (KW)	15.8	15.7	15.6	13.1	18.6	19.6	19.5	19.3

DG164		2 Phase H insulation Industrial					
Voltage		50 Hz 1500rpm			60 Hz 1800rpm		
Series Star		220	230	240	220	230	240
Parallel Star		110	115	120	110	115	120
Series Delta		--	--	--	--	--	--
DG164A	KVA	5.4	5.4	5.4	6.4	6.4	6.4
	KW	4.3	4.3	4.3	5.1	5.1	5.1
	Efficiency (%)	69.6	69.6	70.0	69.5	70.1	70.6
	Power input (KW)	6.2	6.2	6.1	7.3	7.3	7.2
DG164B	KVA	7.4	7.4	7.4	8.8	8.8	8.8
	KW	5.9	5.9	5.9	7.0	7.0	7.0
	Efficiency (%)	73.5	73.8	73.9	73.3	73.9	74.4
	Power input (KW)	8.0	8.0	8.0	9.5	9.5	9.5
DG164C	KVA	9.0	9.0	9.0	10.8	10.8	10.8
	KW	7.2	7.2	7.2	8.6	8.6	8.6
	Efficiency (%)	75.2	75.5	75.7	75.0	75.6	76.0
	Power input (KW)	9.6	9.5	9.5	11.5	11.4	11.3
DG164D	KVA	10.8	10.8	10.8	13.5	13.5	13.5
	KW	8.6	8.6	8.6	10.8	10.8	10.8
	Efficiency (%)	76.5	76.7	76.9	76.4	76.9	77.4
	Power input (KW)	11.2	11.2	11.2	14.1	14.0	14.0

SINGLE BERING

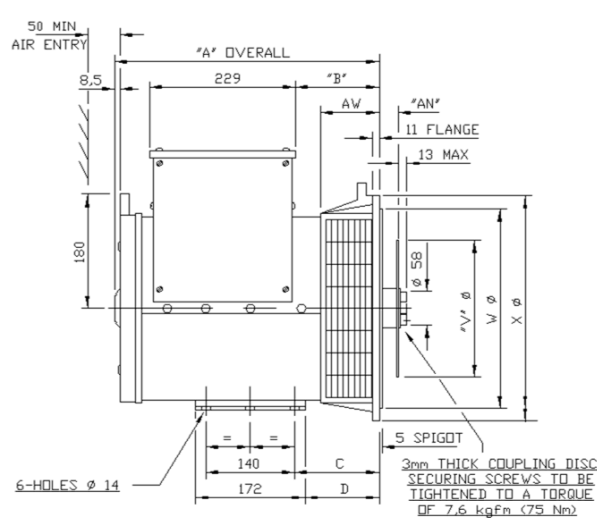

DOUBLE BERING

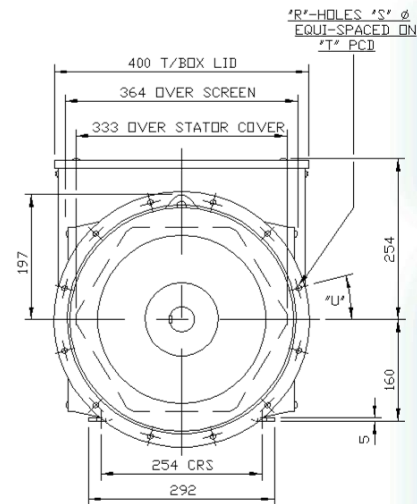
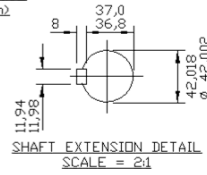
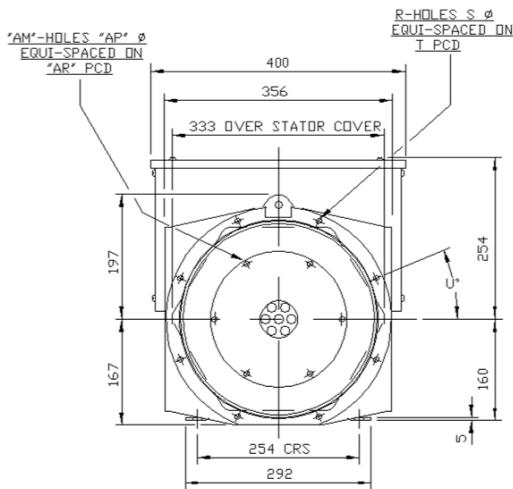
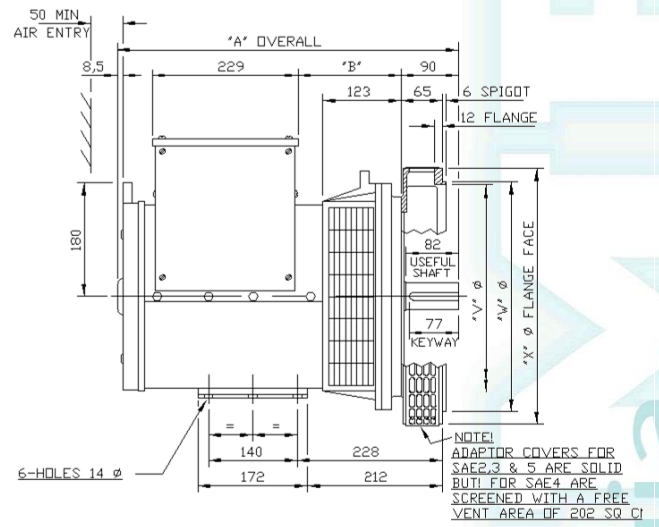

SINGLE BEARING DIMENSIONS		
Code	A	B
DG164A	364.5	93
DG164B	364.5	93
DG164C	391.5	107
DG164D	391.5	107

DOUBLE BEARING DIMENSIONS		
Code	A	B
DG164A	484.5	123
DG164B	484.5	123
DG164C	511.5	137
DG164D	511.5	137

DISC CONPLING					
S.A.E.No.	AN	AM	AP	AR	V
6.5	30.16	6	8.7	200.0	215.8
7.5	30.16	8	8.7	222.2	241.2
8	61.9	6	11	244.5	263.4
10	53.98	8	11	295.3	314.2

FLANGE ADAPTOR									
S.A.E.No.	AW	R	S	T	U	W	X	C	D
2	132.3	12	11	466.7	15	447.6	489	172	156
3	105	8	11	428.6	15	409.5	451	145	129
4	93	8	11	381.0	15	361.9	402	133	117
5	93	8	11	333.3	22.5	314.3	356	133	117
6	124.7	8	11	285.8	22.5	266.7	308	164.7	148.7

FLANGE ADAPTOR							
S.A.E.No.	R	S	T	U	V	W	X
2	12	11	466.7	15	432	447.6	495
3	8	11	428.6	15	396	409.5	451
4	8	11	381.0	15	352	361.9	402
5	8	11	333.3	22.5	301	314.3	356

SINGLE BEARING SHIPPING DETAILS			
Code	Net weight Kg	Gross weight Kg	Packing
DG164A	85	95	56x46x64
DG164B	90	102	56x46x64
DG164C	96	110	56x46x64
DG164D	99	116	56x46x64

DOUBLE BEARING SHIPPING DETAILS			
Code	Net weight Kg	Gross weight Kg	Packing
DG164A	91	101	56X46X64
DG164B	98	108	56X46X64
DG164C	106	116	56X46X64
DG164D	112	122	56X46X64

DESCRIPTION OF MAIN CHARACTERISTIC

GENERAL

Alternator full range covers ratings from 5kVA to 1386kVA, so meeting the most part of needs for industrial, marine, commercial, construction, mining and telecommunications, both for prime or standby power generation.

ALTERNATOR CONSTRUCTURE

Ac generators are self-excited, self-regulated, and supplied with regulator and inbuilt booster.

COMPLIANCE WITH STANDARDS

The generators are designed in compliance with IEC60034-1/60034-2, BS4990 & 5000, VDE0530, NEMA MG1-2006, CSA C/UL.

Certificate ISO 2000, CE conform to the requirements of IEC60034, certificate no. No. 01157 by NQA Certification Co., Ltd.

MECHANICAL FEATURES

The generators are available in either single-bearing or double-bearing.

Single-bearing construction has international general SAE flange adaptors and SAE disc couplings. It ensures the alignment during the assembly operation of generator to the engine.

Double-bearing construction has IMB34 standard forms. It has all SAE adaptors for option. Special constructions on request. Double bearing alternators are balanced with 1/2 key.

All alternators can operate in both directions: clockwise and counterclockwise.

ELECTRICAL FEATURES

OVERLOADS & SHORT CIRCUIT CURRENT

Followings overloads are allowed:

10% for 1 hour

14% for 15 minutes

25% for 5 minutes

50% for 2 minutes

With the addition of an optional Permanent Magnet, alternators can sustain 300% short circuit current for 10 seconds.

UNBALANCED LOAD

The alternators permit an unbalanced load of 25% rated current. The deviation of line voltage is less than 5%.

INSULATION

The insulation system is class 'H'

Vacuum pressure Impregnation

Windings and Electrical Performance

Generator stator is wound to 2/3 pitch. This eliminates triplen (3rd, 9th, 15th...) harmonics on the voltage waveform and is found to be the optimum design for trouble-free supply of non-linear loads.

TELEPHONE INTERFERENCE

TIF (as defined by BS4999 Part 40) is better than 2%. TIF (as defined by ASAC50.12) is better than 50.

RADIO INTERFERENCE

The alternators are supplied with interference suppression grade N to VDE 0875.

DAMPER WINDING

This arrangement provides the alternator with excellent damping against torsional vibrations that occurs during changes in load and when running in parallel.

ACCESSORIES & OPTION

Droop kit for sharing of reactive current during parallel operation

- Remote voltage potentiometer
- PT100 thermal protection embedded in stator windings
- Anti condensation heaters
- IP23 protection
- Special treatment for damp-saline or corrosive environment
- Permanent Magnet
- Control panel with LCD digital meter

GENERAL NOTES

All ratings are base in 40°C ambient temperature at 1000m altitude.

Site altitude exceeds 1000m above the sea level, (ambient temperature 40°C°)

1000 mt. A.s.l.= 100%; 1500 mt. A.s.l.= 97%; 2000 mt. A.s.l.= 94%; 2500 mt. A.s.l.= 91%;

3000 mt. A.s.l.= 87%; 3500 mt. A.s.l.= 82%

Power factor cos. $\Phi < 0.8$

Cos. Φ 0.8-1= 100%; Cos. Φ 0.7= 96%; Cos. Φ 0.6= 92%; Cos. Φ 0.5= 91%; Cos. Φ 0.4= 90%

Re-seller