

Instruction manual

Marine generating set

QMS 16M

QMS 21T

QLS 22T

Contents

Safety precautions	3
Presentation	6
Fuel supply	6
Environmental responsibility	6
Spare parts	6
Identification numbers	7
About the generator	7
Checks before commissioning	7
Principal parts of the generating set	8
Instrument panel	10
Technical characteristics	11
Operation of the generating set	12
Before starting	12
Starting the generating set	12
During operation	13
Stopping the generating set	13
Maintenance	14
Daily checks	15
Air filter	15
Fuel system	16
Bleeding the fuel circuit	16
Replacing the fuel filter	16
Replacing the fuel prefilter	16
Draining the water from the fuel prefilter	16
Lubrication system	17
Checking the oil level	17
Draining the engine oil	17
Replacing the oil filter cartridge	17
Cooling system - Coolant	18
Draining and rinsing the cooling circuit	18
Coolant filling	18
Cooling system - Seawater	19
Cleaning the seawater filter	19
Draining and rinsing the seawater circuit	19
Replacing the seawater pump rotor	19
Engine electrical system	20
Alternator belt	20
Check the electrolyte level	20
Generating set storage procedure	20
Installation recommendations	21
Troubleshooting	22

Safety precautions

Read this chapter carefully as it concerns your safety. Most accidents are caused by failing to follow basic safety rules. Be aware of the possible risks involved in handling your generating set and make sure you take the necessary precautions to protect yourself, those around you and your equipment.

This manual contains important safety indications and information.

They are as follows:

⚠ Warning! : This symbol indicates the risk of accidents and serious personal injury, substantial property damage or serious mechanical faults if the instructions are not followed.

⚠ Caution! : Indicates a risk of personal injury and/or property damage when handling a component.

Notice: Indicates that important information must be known in order to facilitate handling or in particular cases.

Using and handling a generating set entails risks that could prove to be extremely dangerous. Some work requires specific knowledge and equipment. This work should be carried out by Nanni Diesel authorised personnel or by a professional. If you have to work on the generating set, carefully follow the safety instructions set down in this manual.

Certain information is displayed directly on the generating set in the form of icons. This information helps you to quickly identify the location of certain components and avoid possible hazards when working on the set.

Ensure these indications are always visible and replace them if necessary.



Indicates that it is essential to read the instructions carefully before handling the generating set.



Indicates electrical hazards.



This icon indicates a risk of fire.



Indicates the hot parts entailing substantial risks of burns.



Stipulates that you are strongly recommended against smoking and producing flames or sparks in the vicinity.



Indicates an area containing pressurised fluids.



Indicates the hazardous rotating parts.



Indicates the de-aeration orifice(s) (air bleed)



Indicates where to check the coolant level



Indicates where to check the engine oil level.



Indicates the coolant drain orifice.



Indicates the oil drain orifice.

⚠ Exhaust gas

Exhaust gases contain carbon monoxide. This colourless and odourless gas is extremely harmful and could lead to poisoning which could result in loss of consciousness or death. The first symptoms of carbon monoxide intoxication are as follows:

- Dizziness
- Nausea
- Headache
- Throbbing temples
- Vomiting
- Fatigue and falling asleep
- Tense muscles

If you or anyone else in the vicinity of the generating set experiences any of these symptoms, leave the area of operation of the generating set and find fresh air. If the symptoms persist, consult a doctor and have your generating set checked.

⚠ Risk of electric shock

Never touch the electrical connectors when the generating set is operational. The voltage at the connector terminals can be lethal.

Do not work on the generating set without protection: protective goggles and gloves, insulating blankets etc.

Always disconnect the generating set and cut the current before working on the electrical system. Isolate the shore power supply to all the electrical circuit equipment.

Ensure your clothing and skin is not damp or sweaty when handling electrical equipment. Remove watches, bracelets and jewellery when working on electrical equipment.

Handling a capacitor that is still charged can be dangerous and cause electrocution.

⚠ Risk of burns

Never touch the hot parts of the generating set or the exhaust circuit.

An operational generating set gets very hot: the exhaust elbow and pipe, turbocompressor, starter, oil sump, oil, coolant in the hoses and pipes are hot and can burn.

Always check the coolant level before starting the generating set.

Fluids ejected under pressure can cause serious injury. Release all the pressure in the circuits before removing the caps.

Never open the coolant and oil circuit caps when the generating set is operational and/or hot.

Never start or run the generating set when the oil fill cap is not screwed on as hot oil could spray out.

If you come into contact with any of these fluids, consult a doctor immediately.

If the generating set gets too hot, switch it off and disconnect it and wait for it to cool down before handling.

⚠ Risk of fire

Do not smoke near the generating set and keep it away from sources of ignition (flames or sparks) or any other potential flammable vapour or liquid sources.

Do not run the generating set without an air filter.

Do not run the generating set in an area in which flammable or explosive materials are stored or where gas is present. Ensure there are no flammable liquids in the engine compartment.

Immediately clean up any liquids spilled over yourself or the floor and keep the engine compartment clean and accessible so as to minimise the risk of fire. Be careful as fuel can burn.

⚠ Risk of explosion

Explosions caused by fuel vapour can cause serious injury! Carefully follow the safety rules when filling the fuel.

Open and ventilate the storage area of the generating set after filling. Check that there are no fuel vapours or leaks before starting the fan (if fitted). Switch the fan on for 5 minutes before starting the generating set.

All fuel vapours are flammable and explosive. Be careful when handling and storing fuel. Store the fuel in a ventilated area away from sources of ignition (sparks or flames) and out of the reach of children.

Stop the generating set before filling with fuel or lubricant. Do not smoke near the generating set and keep it away from sources of ignition (flames) when filling with fuel and/or lubricant. Wear gloves when investigating possible leaks.

Do not alter or damage the fuel circuit. Close the fuel circuit whenever you work on it.

Ensure you always have an appropriate working extinguisher to hand.

⚠ Accidental starting

Accidental starting can cause serious injury and even death!

Disconnect the battery before working on the generating set.

Ensure no one is alongside the generating set or working on the set before starting it.

Ensure all the protection mechanisms are in place before starting the generating set.

⚠ Risk of battery explosion

A battery explosion can cause serious injury and even death!

Do not smoke near the batteries and keep them away from sources of ignition (flames or sparks). They produce hydrogen which could ignite or explode on contact with an electrical arc or a flame. Switch off all electrical appliances in the vicinity when you are working on the batteries. Ensure the battery storage compartment is corrected ventilated.

Avoid touching the battery terminals with metal tools so that no sparks are created which could cause an explosion. Remove your rings, bracelets and necklaces before handling the batteries.

⚠ Battery acid

The acid in batteries can cause serious injury and even death!

When servicing the batteries, wear protective gloves and goggles. Batteries contain sulphuric acid which is highly corrosive.

Acid can spurt from batteries when they are handled. If the acid comes into contact with the skin, rinse thoroughly in fresh water and consult a doctor.

⚠ Exhaust gas

Ensure the exhaust circuit correctly expels the gas produced by the generating set.

Regularly check that the exhaust circuit is free of leaks and that the exhaust elbow is correctly affixed.

Operate the generating set in a well aerated and ventilated area away from other people. Run the fan when the generating set is operational.

⚠ Rotating parts

Rotating parts can be extremely dangerous and cause serious injury and even death!

Do not work on the generating set when it is operational. If work on the engine when running is absolutely necessary, do not touch any hot or rotating parts.

Baggy clothing, hair or objects could be pulled in and/or caught and cause serious injury or substantial property damage.

Do not wear bracelets, necklaces or rings when working on a generating set.

Check that the bolts and screws are properly tightened and that the protection mechanisms are in place.

Do not check the fluid levels or tension of the alternator belt when the generating set is operational.

⚠ Lifting the generating set

To lift the generating set, use the hoisting eyes on the appliance.

Always check the robustness and overall condition of the lifting equipment. Use suitable gear (cables, beams, machines, etc.) to lift your generating set. Check that your gear is capable of lifting the set.

Lifting cables and chains must be able to move parallel to each other.

Do not forget that any additional equipment mounted on the generating set could alter its centre of gravity. When lifting the set, it should remain as parallel as possible to the ground.

⚠ Maintenance and spare parts

Nanni Diesel engines are designed to meet the different emission standards while delivering maximum service life and reliability.

Regularly servicing and replacing parts with original Nanni Diesel parts will ensure the generating set continues to function optimally.

These parts can be ordered from all Nanni Diesel dealers throughout the world.

⚠ Chemical products

The different fluids used to run the generating set are a health hazard.

Carefully read the instructions on the packaging of these products and always check that the ventilation in the hold space is adequate.

Presentation

Thank you for choosing a Nanni Diesel generating set!

Contact a Nanni Diesel authorised dealer for the servicing of your equipment. A list of dealers can be found on our web site:

www.nannidiesel.com

Nanni Diesel generating sets are the product of many years of experience in the development of marine engines and equipment designed for use in open seas.

Before using, ensure you have the correct manual for your set. We will explain how to identify your equipment and its principal specifications in the chapters to follow. If you don't have the correct manual, please contact your Nanni Diesel authorised dealer.

Carefully read all of this generating set instruction manual and the generator documentation before starting it.

Pay particular attention to the information on personal safety. This manual must always be to hand where the generating set is used.

We recommend that you visually check the overall condition of your generating set before and after using it each time so that you familiarise yourself with the different components and can more easily detect any fuel, oil or coolant leaks or abnormal wearing of the principal parts.

All the information and specifications in this manual are based on the technical data applicable at the time of its publication. Changes and updates may be made by Nanni Diesel without notice.

Certain images, diagrams or equipment described in this manual may not exactly represent (or be part of) your generating set order.

Fuel supply

Ensure that the fuel contains no residues. If it does, use special filters.

Avoid using fuel mixed with water or other substances as you may damage the engine.

The engine performance is influenced by the fuel temperature, the temperature and relative humidity of the exhaust air and by the altitude.

Environmental responsibility

Nanni Diesel designs its engines to have minimum environmental impact and a maximum service life. This objective, however, can only be achieved with your full cooperation. Our operating and maintenance instructions are to help you to protect your generating set and adopt responsible behaviour vis-to-vis the environment.

Observe the warning and caution labels affixed to the generating set.

Ensure you only use the fuels and oils recommended in this manual. Using another type of fuel or oil could cause major generator malfunctions: higher consumption, reduced engine service life, greater discharge of exhaust gases.

When draining the oil and changing the oil or fuel filter, dispose of the waste in the appropriate container. These fluids cause major damage to flora and fauna if discharged into nature.

The different fluids used to run the engine are a health hazard. Carefully read the instructions on the packaging of these products and always check that the ventilation in the storage compartment is adequate.

Spare parts

You can order the emergency parts below from any Nanni Diesel authorised dealer. Keep a copy of the list of parts with the set.

These emergency parts could allow you to repair your engine in the event of a fault.

- V-belt
- Seawater pump rotor kit
- Engine oil filter
- Fuel filter (filtering part)
- Injection tube
- Glow plug
- Air filter
- Nanni Diesel blue paint

Certain items may vary depending on your order. Contact your authorised dealer for more information.

Identification numbers

Your generating set has 2 identification plates: one for the engine and one for the generator.

Keep these plates accessible and in good condition. Record and keep the engine and generator serial number and designation. These numbers will be useful if you work on your set, order parts or invoke the warranty.

The engine identification plate is as follows:



- The TYP inscription indicates the commercial designation of the generating set (eg. QMS10T).
- The NR inscription indicates the engine serial number.
- The CODE inscription lists the various specifications of your engine.

The elements on the alternator identification plate are explained in the alternator documentation.

About the generator

Refer to your generator manual for more information about this component.

The generators are installed and run for the first time in our factory. A professional electrician should connect the generating set to the craft's electrical circuit following the applicable safety standards.

Always check the installation of your generating set before handling it. Check the overall condition of the generator, the tightness of the assembly screws and the stability of the generator as a whole.

Checks before commissioning

⚠ Caution! : Your generating set must be installed by a shipyard or authorised representative following the on-board assembly instructions.

The electrical connections must also be carried out by qualified personnel. The electrical installation must be equipped with all the mechanisms for protecting people and property in accordance with the applicable standards.

When the set has been installed on board and before removing the protective elements covering the different orifices, clean the exterior surface of the generating set.

For transportation reasons, some of our generating sets are delivered without their operating fluids. In all cases, you must:

- Check the levels and fill the engine oil if necessary.
- Fill the exchanger with coolant and degas if necessary.
- If necessary prime the raw water circuit
- Check the belt tension.
- Check the tightness of the different connections and drain caps (coolant and oil).
- Check the tightness of the alternator electrical lugs (check the cabling by referring to the corresponding documentation), battery terminals, circuit breaker, connection of extension sections, battery electrolyte level.
- Make a final check of the fixing elements and a visual check of the generating set as a whole.

Some of these operations are explained in more detail later in this manual.

⚠ Caution! : The modern fuel engine is precision equipment that requires the use of a high-quality fuel and lubricant.

Principal parts of the generating set (QMS16M-QMS21T)

Some equipment may not be part of your generating set.

- | | |
|---------------------------|------------------------------------|
| 1. Engine alternator | 11. Oil filter |
| 2. Engine alternator belt | 12. Oil drain pump (option) |
| 3. Starter | 13. Oil gauge |
| 4. Heat exchanger | 14. Fuel filter |
| 5. Coolant fill orifice | 15. Fuel pump |
| 6. Coolant pump | 16. Supports |
| 7. Seawater pump | 17. Generator |
| 8. Exhaust elbow | 18. Generator identification plate |
| 9. Air filter | 19. Engine identification plate |
| 10. Oil fill orifice | 20. Generating set hoisting eyes |

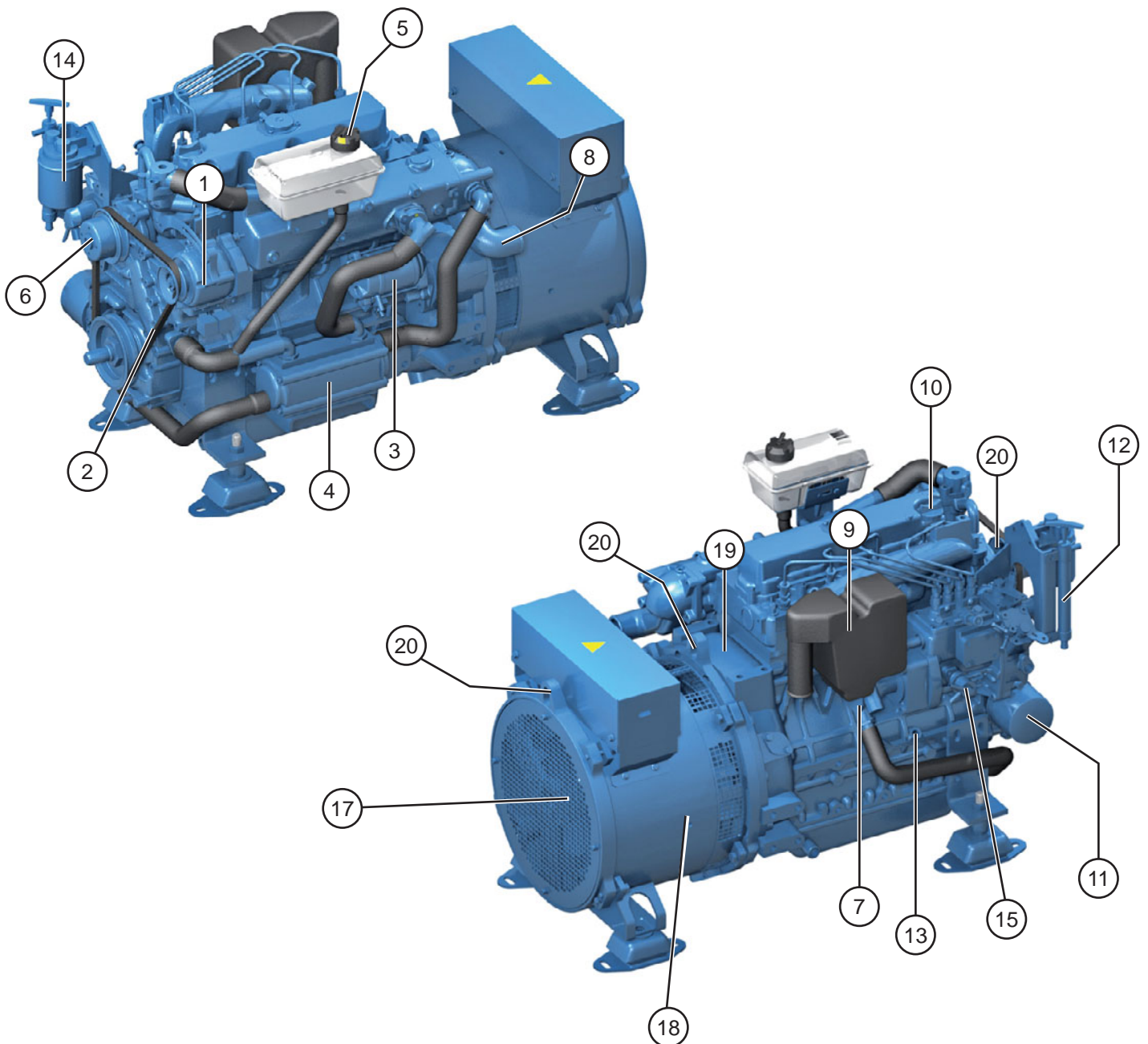

Principal parts of the generating set (QLS22T)

Certain equipment may not be part of your generating set.

- | | |
|---------------------------|------------------------------------|
| 1. Engine alternator | 11. Oil filter |
| 2. Engine alternator belt | 12. Oil drain pump (option) |
| 3. Starter | 13. Oil gauge |
| 4. Heat exchanger | 14. Fuel filter |
| 5. Coolant fill orifice | 15. Fuel pump |
| 6. Coolant pump | 16. Supports |
| 7. Seawater pump | 17. Generator |
| 8. Exhaust elbow | 18. Generator identification plate |
| 9. Air filter | 19. Engine identification plate |
| 10. Oil fill orifice | 20. Generating set hoisting eyes |

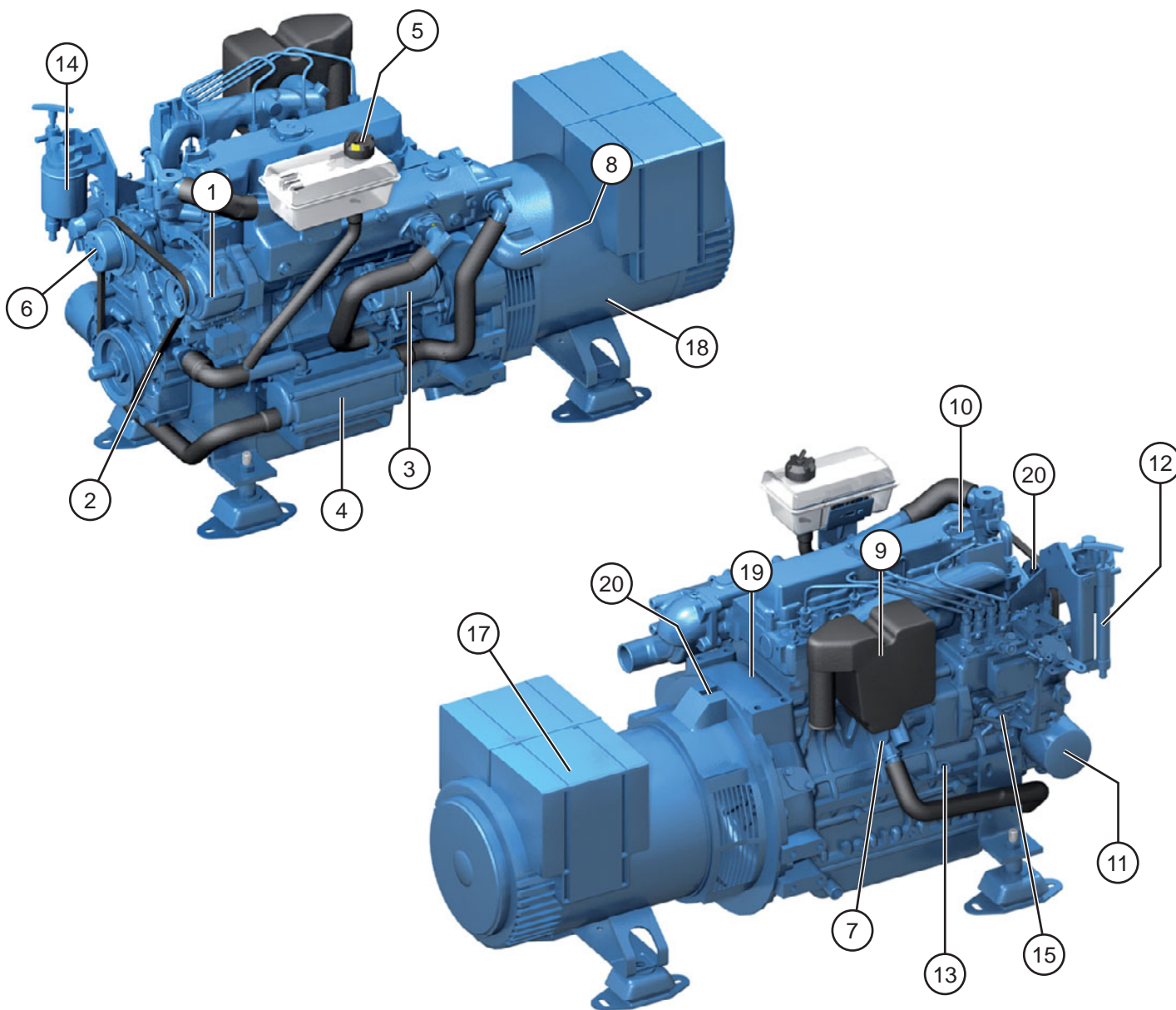

Instrument panel

The instrument panel allows you to start and stop the generating set, and provides you with important information when the generating set is under operation. Check this informations regularly while operating the generating set. Contact an authorized Nanni Diesel dealer if your generating set is equipped with instruments different than those described in this chapter.

⚠ Caution! : On a soundproof generating set, the local/remote selector must be in *remote* position to start the generating set using the instrument panel.

⚠ Caution! : If the coolant temperature rises or the oil pressure falls abnormally, the corresponding indicators will illuminate and **the generating set will stop automatically.**

- 1. Heating.** This indicator illuminates when the glow plugs are heating the combustion chambers (if fitted on your generating set).
- 2. Coolant temperature.** This indicator illuminates and an audible alarm sounds if the coolant in the cooling circuit overheats.
- 3. Battery charge.** This indicator illuminates when the set is switched on. If it lights when the generating set is running, this indicates an engine alternator charging fault.
- 4. Oil pressure.** This indicator illuminates and an audible alarm sounds if the oil pressure in the lubrication circuit falls.
- 5. Indicator showing presence of water in fuel filter (if fitted).** This indicator illuminates when there is too much water in the fuel filter.

- 6. On indicator.** This indicator shows that the generating set is powered (ignition).
- 7. Start/Stop buttons.** This component starts and stops the generating set. The ON/STOP button switch powers up and stops the engine. The START button starts the genset.
- 8. Engine oil pressure** *Caution! This indicator does not show the engine oil level.* This indicator shows the oil pressure. An audible alarm sounds and the generating set stops if the oil pressure in the lubrication circuit falls.
- 9. Coolant temperature.** Indicates the coolant temperature. An audible alarm sounds and the generating set stops if the coolant in the cooling circuit overheats.



Tableau Luxe GE



Tableau Eco GE

Technical specifications

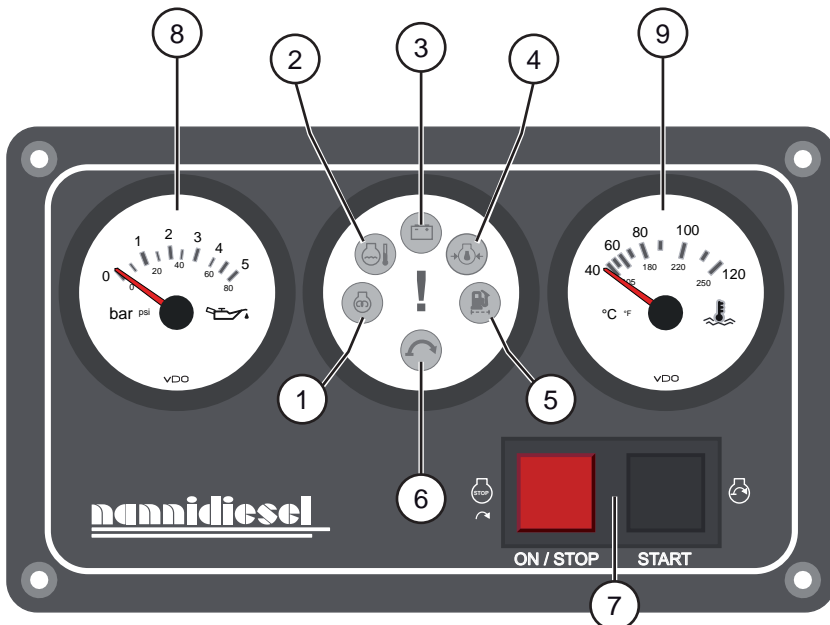
ELECTRICAL CHARACTERISTICS	QMS 16M	QMS 21T	QLS 22T
Continuous / Max power (kW)*	13.9 / 16.2	14.3 / 16.7	15.1 / 17.7
Volts / Number of phases	230 / 1	400 / 3	400 / 3
Continuous / maxi current (A)	60.4 / 70.4	25.8 / 30.1	27.2 / 31.9
Frequency (hz)	50		
SPECIFICATIONS OF THE ENGINE	QMS 16M	QMS 21T	QLS 22T
Number of cylinders	4 in line		
Capacity (cm ³)	2197		
Bore/stroke (mm)	87 x 92,4		
Engine speed (rpm)	1500		
Weight without frame (kg)	328	328	360
INJECTION SYSTEM	QMS 16M	QMS 21T	QLS 22T
Combustion principle	Indirect E-TVCS		
Intake	Natural		
Injectors	Type Bosch DN-0PD mini		
Injection pressure (bar)	140		
Fuel type	Gazole NF-EN 590 / Diesel Fuel N°2-D ASTM D975		
LUBRICATION	QMS 16M	QMS 21T	QLS 22T
Oil pressure at max. revolutions (bar)	3 - 4.5		
Type	API-CF mini.		
Grade	15W40		
Capacity in litres (flat four engine)	7.5		
COOLANT	QMS 16M	QMS 21T	QLS 22T
Capacity (litres)	9		
Type	50% water + 50% mix anti-freeze and anti-corrosion additive		
DISTRIBUTION	QMS 16M	QMS 21T	QLS 22T
Cold valve clearance - Intake (mm)	0,18 to 0,22		
Cold valve clearance - Exhaust (mm)	0,18 to 0,22		
Valve shrinkage	+0,05 to -0,15		
ELECTRICAL CIRCUIT	QMS 16M	QMS 21T	QLS 22T
Glow plug resistance (ohm)	0.8		
Alternator	12 - 40		
Battery mini capacity (Ah)	120		
Starter (V-kW)	12 - 1		

* Continuous (COP) and max (PRP) power rating according to ISO 8528-1
 Certain specifications may vary depending on your order.

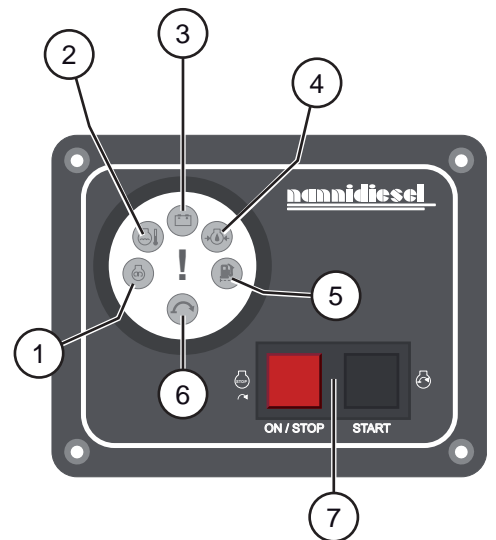
Operation of the generating set

Before starting

⚠ Caution! : Before starting, ensure that the seacock is open as the seawater pump rotor can be damaged if run dry for just a few seconds. **Generating sets with a Keel Cooling system are not fitted with a seawater pump.**

Never use a starting aerosol or any other equivalent product. These products are highly flammable.

Before starting the engine and before the set is used each time:

- Check the fuel level
- Open the fuel shutoff valve
- Open the seacock (if fitted)
- Check the engine oil level and fill with the recommended oil if necessary. See the "Maintenance" section for more information.
- Check the coolant level and fill with the recommended coolant if necessary. See the "Maintenance" section for more information.
- Open the hold space panel(s) to fully ventilate the hold space if it is not equipped with a fan. Otherwise run the fan in the hold space for 5 minutes.
- Close the battery switch (ON position) and check that the emergency stop is not activated.

⚠ Caution! : Ensure you have replaced the protection elements before starting the generating set.

Notice: If your engine has not been used for several months or if the fuel circuit has been drained, use the priming pump situated above the fuel filter. This fills the fuel circuit if it has drained out or after a circuit component has been replaced.

Starting the generating set

⚠ Caution! : On a **soundproof generating set**, the local/remote selector must be in **remote** position to start the generating set using the instrument panel.

Carry out the following operations to start your generating set in complete safety:

1. Press the ON/STOP button. All of the indicators illuminate and an audible signal sounds. This stage allows you to check that these elements are working properly. After a few moments, only the oil and battery charge indicators will remain lit.

2. Hold the START button at midcourse to begin preheating. The PREHEAT warning light illuminates. Hold the button for 5 to 20 seconds according to the temperature on the outside. Push fully the button to start the generating set.

⚠ Caution! : If the generating set does not start on the first attempt, repeat the manoeuvre, waiting 5 to 15 seconds between each attempt, with the set switched off. Never force it as there is a risk of water backflow into the engine via the exhaust system.

Check the indicators on the instrument panel after starting and when operating the set.

Check also that the seawater is running through the exhaust and check there are no fuel or water leaks.

⚠ Caution! : If the coolant temperature rises or the oil pressure falls abnormally, the corresponding indicators will illuminate and **the generating set will stop automatically.**

Identify and eliminate the cause before restarting the engine. See the "Fault-finding" section for more information.

During operation

Regularly check the indicators on the generating set instrument panel.

Notice: If the generating set runs continuously, the oil level should be checked every 8 hours.

Never press the START button when the generating set is under operation.

Alarm indicators

If the oil pressure is too low in the engine lubrication circuit, the "engine oil pressure" indicator illuminates and an audible alarm sounds and the generating set stops.

If the coolant temperature is too high, the "coolant temperature" indicator illuminates and an audible alarm sounds and the generating set stops.

⚠ **Warning!** : Never open the coolant and oil circuit caps when the engine is running and/or hot.

If the voltage supplied by the engine alternator drops, the "Battery charge" indicator illuminates.

See the "Fault-finding" section for the basic checks to make in the event of a fault.

In all cases, if one or more of these problems persist, stop your generating set except in emergencies and contact your Nanni Diesel authorised dealer.

Stopping the generating set

Before stopping the generating set, cut the power of the electrical appliances connected to the craft's on-board electrical circuit.

Depress the ON/STOP button and then release.

Emergency stop

You can stop the engine manually if the standard shutdown procedure is not working or in an emergency. Use the emergency stop button situated on the electrical junction box or cut the fuel supply.

⚠ **Warning!** : Working on a running motor is extremely dangerous.

After the engine has stopped

Open the circuit breaker (battery supply closed), close the seacock (if fitted) and the fuel shutoff valve. Check the condition of the compartment in order to identify any leaks.

⚠ **Warning!** : Even after your generating set has stopped, elements remain hot and pressurised for several minutes. As far as possible, limit work on the generating set immediately after stopping it.

⚠ **Caution!** : **If your generating set is connected to a seawater intake**, if the craft is being towed, stop the generating set and always close the seacock to prevent the generating set from accidentally filling with seawater.

Maintenance

The regular maintenance of your generating set is essential for ensuring optimal reliability and service life. The following operations and the those described in the Silverwake warranty booklet will enable you to extend the service life of your engine and reduce its impact on the environment.

During the warranty period, it is essential that all work is carried out by a Nanni Diesel authorised dealer. However, some regular checks, particularly those made each time the engine is used, can only be made by the user.

Some operations are explained to you further on so that you can work on the engine in an emergency or if there is no repair centre nearby. However, we recommend you have your work checked by a Nanni Diesel authorised dealer.

⚠ Caution! : As far as possible, limit work on the engine when it is under operation and/or when you are sailing.

These instructions only describe a part of the maintenance operations to be carried out. Find the complete list on the Silverwake warranty booklet. The operations listed on the Silverwake must be carried out by an authorised Nanni Diesel technician.

The instrument panel shows you how long your engine has run since its commissioning.

Notice: Some equipments are optional and may not be part of your generating set.

In order to preserve the mechanical qualities of the engine and prolong its service life, we recommend you follow the instructions below:

Use a coolant made of 50% water and 50% of pure antifreeze. Use clean and distilled water for the mix: Water that is too hard will produce limescale build-up and will reduce the cooling system's effectiveness.

The cooling system allow the engine to operate at a optimal temperature. The cooling system must be filled with a coolant that protects the engine against internal corrosion and from freezing, if the climate requires it. A faulty operation of the cooling system reduces its efficiency and therefore the engine's service life.

Use antifreeze depending on climatic conditions: it will protect against freezing to a temperature of less than -25°C. If the engine must be switched off for a long period in an environment with a high risk of frost, the coolant must be drained.

Do not engage the starter motor for more than 10 seconds: The continuous use of the starter for more than 10 seconds will damage the system.

Choose a diesel fuel meeting standard DIN-EN 590. If using Biodiesel (according to UNI EN14214 specifications) this can be blended up to 5% with a fuel available in Europe (according to the DIN EN 590 standard: a lower quality fuel will result in poor combustion, which may cause starting problems and heavy smoke emissions.

Draining the fuel tank: Remove the deposits in the fuel regularly. The first time after 50 hours of operation and then every 300 hours.

Use a good-quality lubricant: Poor-quality lubricating oil will damage the engine in terms of the wear of the parts, jamming, etc., or rather reduce its service life. Use an API-CF mini type oil adapted to the climatic conditions and temperature (Contact your local dealer for further informations).

Daily checks

Regularly check the condition of the generating set and its compartment before and after it is used: check for the presence or not of fuel or oil leaks, the tightness of the different clamps and bolts, the condition of the belts, hoses and the various electrical cables, the wear of the zinc anode (if fitted), the battery electrolyte level.

These relatively simple checks can help you to detect possible faults before major work on your set is required.

⚠ Caution! : Do not let oil, fuel or grease deposits build up around the generating set as they may increase the risk of fire in the engine compartment.

Check the operation of the different lamps and indicators situated on the instrument panel. Take care not to get the generator wet when cleaning the engine.

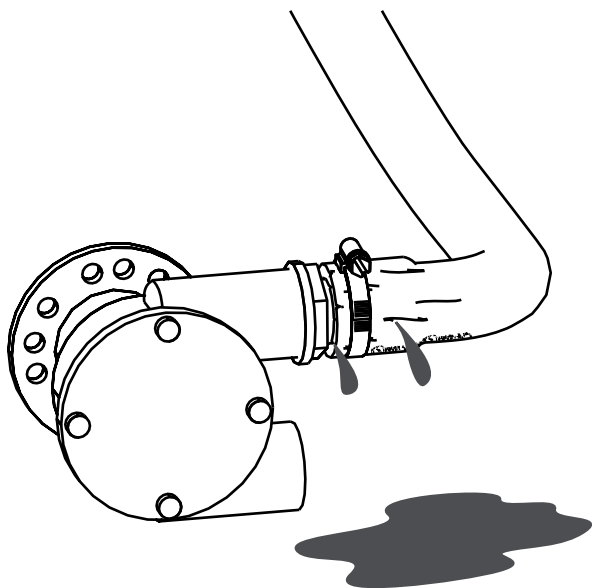

Air filter

⚠ Caution! Carry out these operations when the generating set is stopped and cold.

The air filter essentially reduces the level of noise made by the engine and purifies the air injected into the combustion chamber.

If the filter is too clogged, replace it. If it is not:

- Remove the clamp and the filter.
- Clean the filter with compressed air
- Put it back in its place with the clamp correctly tightened.

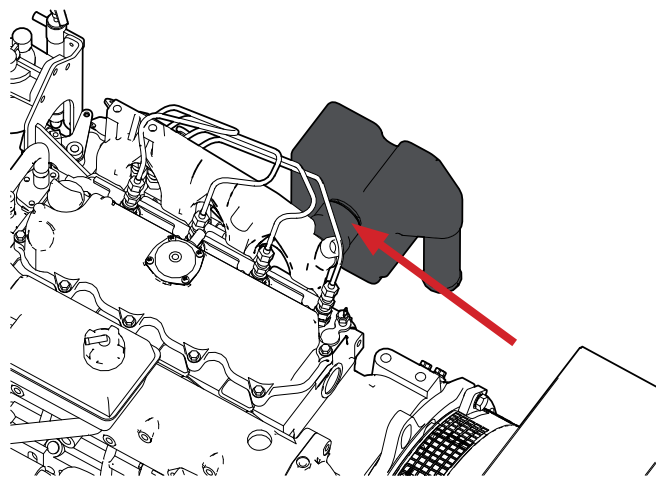

Fuel system

⚠ Warning! : Total cleanliness must be guaranteed when working on the fuel circuit. No impurities must enter the injection pump and the injectors. Carry out each of these operations with the engine cold and stopped.

Bleeding the fuel circuit

The fuel circuit is self-priming but manual bleeding is required after replacing the filter, after have running out of fuel or after a work on the circuit if it has been emptied.

- Loose the drain valve screw **A** on the engine fuel filter support.
- Pump the priming pump by pressing the button **B** repeatedly until bubble-free fuel comes out of the drain valve screw.
- Tighten the drain valve screw and lock the hand pump.

⚠ Caution! : Avoid draining all the fuel in the filter when venting. If so, remove the filter and replenish with fuel before replacing it and repeat the venting operations.

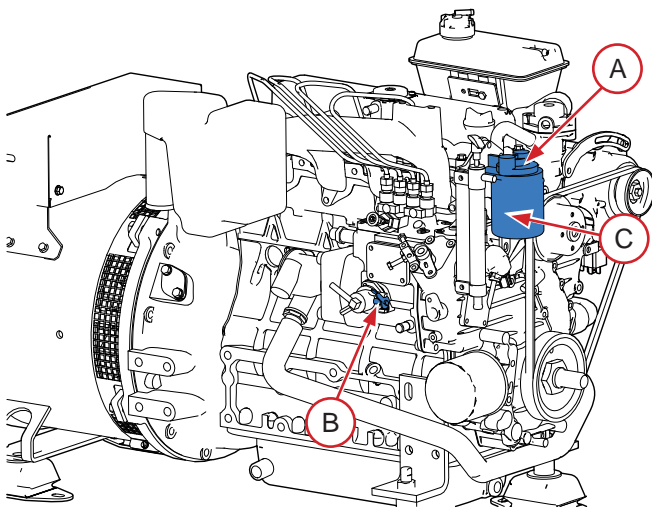

Replacing the fuel filter

This filter treats the water and impurities in the fuel before it enters the injection circuit.

- Cut the fuel intake at the tank.
- Place a receptacle under the filter and then remove the used filter **C** cartridge.
- Apply a thin layer of fuel over the seal surface of the new filter cartridge before fitting it.
- Tighten it by hand until the filter makes contact with the filter head then tighten it by a half-turn.

- Untighten the drain valve screw to release the air. Open the fuel valve again and drain the circuit.
- Start the engine and check the assembly is leak-tight.

⚠ Caution! : Used filters must be disposed of in an appropriate container.

Replacing the fuel prefilter

The fuel prefilter is an optional component that purifies the fuel before it is injected in the engine. These instructions are given as an example only.

- Close the fuel shutoff valve on the fuel tank.
- Place a receptacle under the fuel prefilter. Remove the filter tank
- Drain and clean the filter tank.
- Replace the cartridge and re-install the tank.
- Open the fuel valve. Drain the feed system then start the engine to check the leak-tightness.

Draining the water from the fuel prefilter

Before starting the engine each time, ensure there is no water in the fuel prefilter. If there is water, place a tray under the fuel prefilter and then drain the water and impurities using the bottom cap/valve.

Lubrication system

Checking the oil level

⚠ **Caution!** : Carry out these operations with the engine stopped. Hot oil and hot surfaces can burn.

If oil of a different brand or viscosity to the previous is used, drain the old oil. Never mix two different types of oil. Observe the recommended draining intervals.

The oil level should be within the range indicated on the oil gauge. To check the oil level:

- Start the engine and let it run at idle for several minutes.
- Stop the engine and remove the starter key.
- Remove and wipe down the gauge rod.
- Re-insert it and then remove it.
- Check whether the oil level is between the two notches. If the level is too low, add more oil until reaching the specified level.

Top up oil slowly via the filler port located on the top of the engine. Add the oil slowly and wait several minutes before checking the level again. This allows the oil to run into the engine crankcase.

⚠ **Caution!** : Do not fill the crankcase above the maximum level indicated on the gauge.

Draining the engine oil

⚠ **Warning!** : Carry out these operations with the engine stopped. Hot oil and hot surfaces can burn.

- Start the engine and let it warm up for approximately 5 minutes so that oil suction is easier. Stop the engine.
- Use a pail to collect the extracted oil and pump until the oil has been completely extracted. Refill with the new oil (the amount of oil to add is indicated in the technical specifications section).
- Check the level with the gauge, ensuring you do not go above the maximum level.
- Start the engine and check that the oil pressure indicator is extinguished and that there are no leaks in the lubrication circuit. Let the engine warm up for several minutes and then check the oil level again. Fill again if necessary.

Replacing the oil filter cartridge

⚠ **Caution!** : Carry out these operations with the engine stopped. Hot oil and hot surfaces can burn.

- Remove the oil filter cartridge with a filter key.
- Clean the filter support in order to prevent impurities from entering the engine.
- Apply a fine layer of oil over the rubber seal of the new cartridge.
- To install the new cartridge, tighten it by hand until it makes contact with the filter head and then tighten by a half-turn. Over-tightening may lead to the deformation of the seal.
- After replacing the filter, check that the engine oil is not leaking through the seal and check the oil level using the gauge. Add oil if necessary.

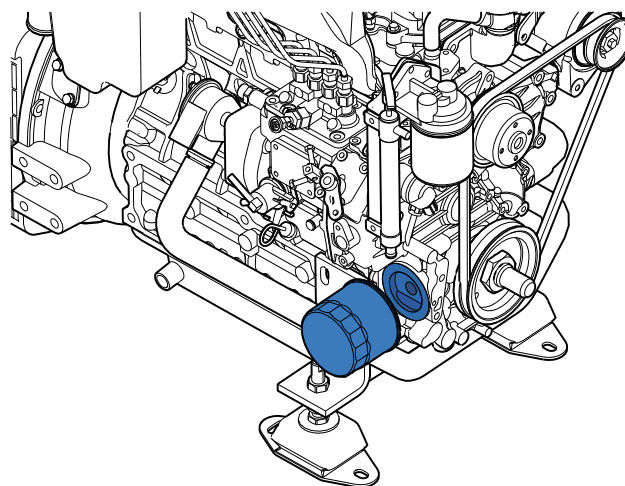

Cooling system - Coolant

The cooling system enables the engine to operate at an optimal temperature. In the case of a cooling by closed heat exchanger, the coolant is cooled by sea water passing through the exchanger. Then it cooled several components of the engine.

In a Keel Cooling system, engine heat is dissipated by passing coolant through tubes incorporated to the hull. Contact the installer of the genset for more informations.

The cooling system must be filled with a coolant comprising 50% water and 50% anti-freeze and anti-corrosion additive.

The coolant must be changed regularly as the additives become less effective over time. Prepare the mix before filling the exchanger. If the generating set must be switched off for a long period in an environment with a high risk of frost, the coolant must be drained.

⚠ Attention! : Never use just water to fill the cooling circuit. Always use a clean receptacle and ensure the fluids are well mixed.

Draining and rinsing the cooling circuit

The coolant in the cooling circuit must be drained in order to remove the various deposits that can build up in the circuit.

Carry out this operation with the engine stopped and cold.

- Place a receptacle under the hose **A** then remove it.
- Remove the fill cap situated on the expansion tank in order to let the coolant flows faster. Let the coolant run out until the exchanger is empty.
- Place a receptacle under the hose **B** then remove it.
- Let the coolant run out.
- Clean the system with fresh water the refit then hoses.

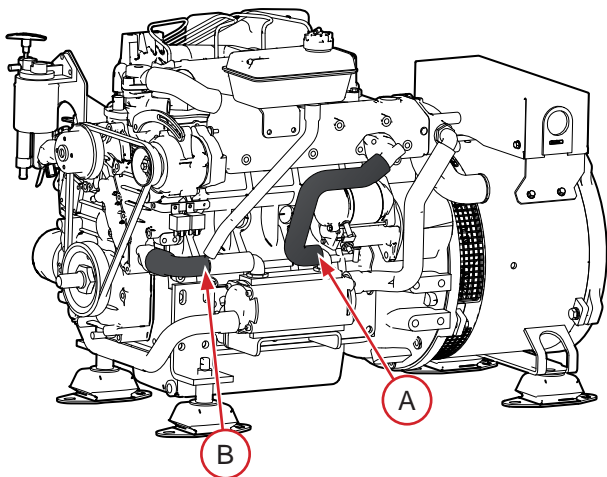

Coolant filling

⚠ Attention! : Do not check the coolant level when the engine is hot. Pressurised coolant can spurt and cause serious burns. Carry out this work with the engine stopped and cold. Only use new coolant when replenishing or adding coolant.

The coolant level must be between the min and max level indicated on the expansion tank.

- Turn the fill cap **A** situated on the expansion tank to its first stop to release the system pressure and then remove the cap.
- Open the plug **B**
- Fill the expansion tank slowly with coolant up to the maximum level in order to let the air escape. When the coolant flows from the orifice **B**, close the plug and fill the expansion tank to the max level if necessary.
- Run the engine for several minutes without load. Stop the engine, wait a few moments, then check the coolant level again. Fill again if necessary.

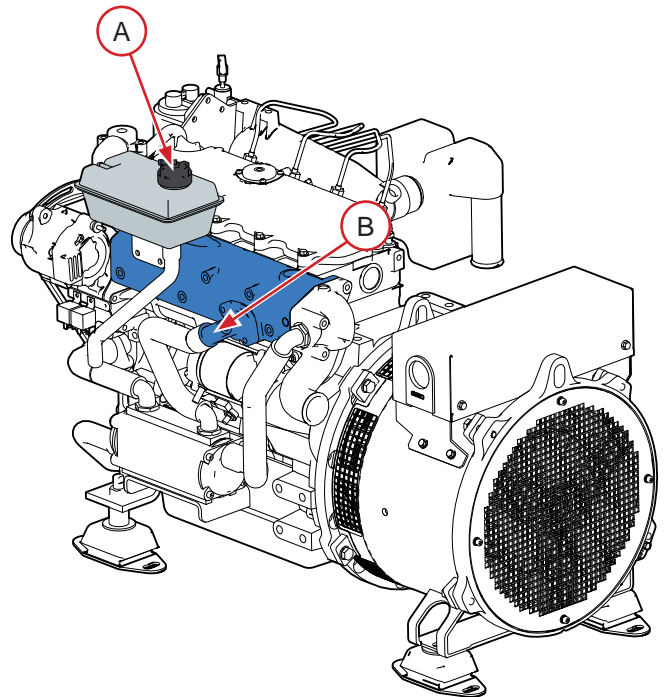

Cooling system - Seawater

⚠ Caution! : When the craft is in the water, there is a risk of water penetrating the craft when working on the seawater circuit. Water can penetrate the craft via components located below the waterline. Close the seacock (if fitted) or prevent water discharge before working on the seawater system !

Cleaning the seawater system is essential to prevent the formation of deposits and salt crystals.

Your generating set may not be fitted with a seawater cooling system (such as in the case of a Keel Cooling system).

Cleaning the seawater filter

The seawater filter is an optional component. These instructions are given as an example only.

- Check the condition of the seawater filter with the engine stopped. If deposits have formed, remove the filter in order to clean it.
- Remove the cover and then the filtering part **A**. Remove all the debris on the housing.
- Rinse the filter and the housing with fresh water and check the condition of the seal, then re-install all the components and check there are no water and/or air leaks in the circuit when operational.

Draining and rinsing the seawater circuit

- Close the seacock.
- Disconnect the hose running from the seacock.
- Place the hose in a receptacle filled with fresh water. Ensure the receptacle you use is large enough as the seawater pump must never be run without water.
- Check that no one is in the vicinity of the engine and then start it. Let the engine run for several minutes, checking that the receptacle is at all times filled with fresh water.
- Once the circuit is fully rinsed, re-connect the hose correctly to the seawater filter.
- Drain also the exhaust circuit. A small amount of water may remain in the bottom of the waterlock box.
- Run the engine for few minutes in order to check for leakage.

Replacing the seawater pump rotor

The seawater pump rotor is an essential component. It must be replaced regularly along with the seal. A worn rotor could crack and damage the cooling system. Always have a replacement rotor on board the craft.

- Close the seacock.
- Remove the seawater pump cap **A** and the seal **B**, then remove the rotor **C** without damaging it.
- Check the condition of the rotor: replace it if even the most minor defect is noted. If the rotor is damaged, drain the seawater system and check that the heat exchanger is not clogged by pieces of rubber. Clean it if necessary.
- Clean the elements.
- Fit a new rotor by turning it clockwise.
- Lubricate the pump casing and the inside of the lid with waterproof grease for rubber.
- Refit the water pump cap using a new seal.
- Open the seacock and then start the engine to check that the circuit is leak-tight.

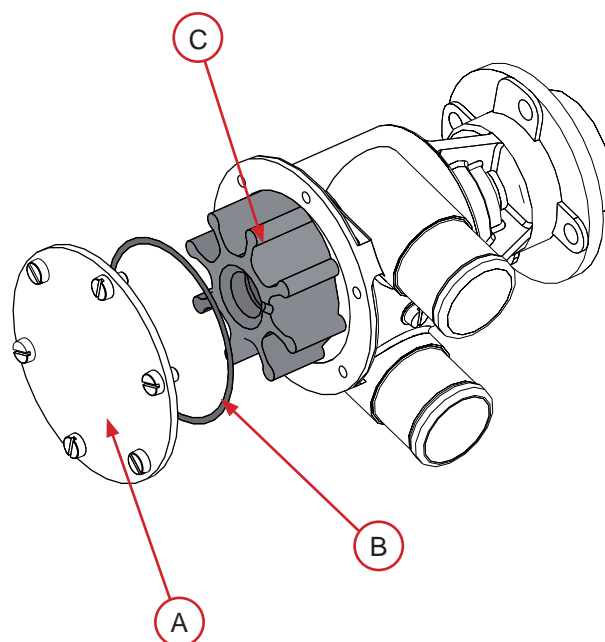

Engine electrical system

⚠ **Caution!** : Stop the generating set and the cut the battery supply before working on the electrical circuit.

Alternator belt

Make this check after running the generating set when the belt is hot.

⚠ **Caution!** : Some parts of the generating set can be extremely hot.

Check the belt tension by pushing down at midpoint between the drive pulley and the alternator pulley.

If the belt is too slack, untighten the alternator fixing bolts **A** and move the alternator to adjust the belt tension.

Visually check the belt: Check that it is not overly worn and that the belt strip is not frayed. Replace it if even the most minor defect is noted.

Check the electrolyte level

The generating set starter battery must remain clean and dry. Oxidation or the deposit of impurities on the battery and on its terminals may lead to short circuits, voltage drops and premature discharging, notably in wet weather.

The battery terminals and the cables must be cleaned with a brass brush in order to remove any oxidation. Tighten the cable terminals and lubricate them with appropriate grease.

If the battery is replaced, use a battery with similar specifications to the previous one.

If starting with an emergency battery and connection cables, proceed as follows:

- Connect the emergency battery to the main battery by connecting the + to the + and the - to the -. When the engine has started, remove the connection cables.

You should disconnect the 2 battery cables when:

- You use a battery charger
- Before carrying out any work on the electrical equipment
- Before carrying out any welding work

Generating set storage procedure

A set of operations will protect the engine during long periods of non-use. For prolonged storage before or after the commissioning, a specific set of measures must be performed. Contact your Nanni Diesel dealer.

Refer to the Silverwake warranty booklet for more informations about these operations.

We recommend that you have all these operations carried out by a Nanni Diesel authorised workshop.

If the engine is likely to be subjected to freezing temperatures, the coolant must be drained.

Restarting the generating set

After operations of winterization, a list of operation must be performed before restarting the generating set. Contact your Nanni Diesel dealer.

Installation recommendations

The recommendations given in this chapter do not cover all the installation possibilities, but offer recommendations and guidelines for installing a Nanni Diesel generating set. Certain equipment may not be part of your order or installation.

Installation

The generating set and the coupled equipment must be accessible for maintenance work. The generating set must be mounted on a rigid and solid structure on the hull that is capable of withstanding all the dynamic stresses and the weight of the set as a whole. The generating set must not be inclined by more than 5° when the craft is stopped.

Avoid installing the generating set too close to walls that are too thin that could reverberate. In all cases, the generating set should not be installed directly on a wood or plywood surface or in contact with walls. A solid steel support will reduce the vibrations and noise produced by the generating set.

The various cables and electrical extension sections must be securely affixed to the generating set and/or to the compartment walls (do not let them hang in the hold).

Ventilation

The temperature inside the compartment must not exceed 50°C with a maximum difference of 20°C in relation to the ambient temperature.

For slow craft, ventilation must be provided by a fan. Fresh air must circulate from front to back. The air intake should be situated at the bottom front of the engine compartment and the exhaust at the top back in order to ensure optimal air circulation.

Electrical installation

An incorrect or faulty electrical installation could cause leakage currents that could affect the galvanic protection of the generating set and consequently the generating set itself. The installer should ensure that all the necessary precautions are taken to guarantee the corrosion protection of the generating set.

Fuel feed system

The generating set must have its own fuel feed system. The tanks must be placed as far as possible at the same height as or slightly higher than the engine.

The fuel return pipe must always be situated under the minimum tank fill level.

The maximum height between the fuel pump and the minimum tank level is of 0.5 m. An electrical pump must be installed above this value.

Cooling system

Your generating set is cooled by a coolant passing through the different parts of the engine. It may also be fitted with a heat exchanger cooled by seawater which, among other things, cools the coolant and the exhaust gases (except in the case of a Keel Cooling system).

In this case, the generating set must have its own seawater cooling system with no connection to the engine system or other equipment. The seawater intake must always face the back of the craft (regardless of the type of craft) and must be as close as possible to the genset.

The height of the seawater filter and the exhaust outlet must be 150 mm above the waterline.

An anti-siphon must always be installed if the generating set is below the waterline. It should be placed at least 500 mm and at most 2 metres above the waterline.

The waterlock box must be positioned as close to the engine and as low as possible.

The exhaust pipe situated between the waterlock and the hull outlet should form a gooseneck (as shown in the diagrams below). The highest point of the gooseneck should be at a maximum distance of 3 metres from the waterlock and at a maximum height of 1.5 metres in relation to the waterlock.

Troubleshooting

This section helps you to understand the different problems that may arise on your generating set. The safest way to correct the problems you may encounter, however, is to contact a qualified engineer. Some operations must be carried out by a qualified Nanni Diesel authorised engineer. These operations are marked in bold in the tables below.

This non-exhaustive list serves as a tool in emergencies and should never be considered a repair procedure. Some of the components listed may not be part of your engine.

Faults and probable causes	
Engine does not start / starter does not turn	
Faults	Solution
Circuit breaker is open or fuse has blown	Check and re-install the circuit breaker or replace the fuse or replace the circuit breaker
Electrical circuit breaker is not working	
Electrical connections are faulty	Check the electrical connections and wires (especially the battery cables) Clean and tighten the connections
Battery faulty	Test and charge or replace the battery if faulty
Starting procedure defective	Read and implement the starting procedure
Fuel tank empty or fuel cock closed	Fill the tank or open the cock
Fuel pump faulty	Replace the pump
Fuel filters clogged or water present	Clean or replace the fuel filters or drain the water from the prefilter then drain the circuit
Fuel contaminated or too old	Drain the tank if contaminated and fill with clean fuel
Fuel pipe or air pipe of tank blocked or bent	Replace the bent pipes or blow in compressed air to remove the obstruction
Air present in fuel injection system	Drain the injection system

Faults and probable causes	
Engine overheats / Engine coolant temperature too high	
Faults	Solution
Seacock is closed	Open the Seacock
Seawater filter is clogged	Close the Seacock and clean the filter
Seawater pump is sucking air	Check the position and seal of the seawater filter cover and the suction hose
Fresh water circuit pump belt is slack or faulty	Re-tighten or replace the belt
Seawater pump rotor is faulty	Replace the rotor
Insufficient coolant	Fill with coolant and check that the cooling system is leak-tight
Thermostat is malfunctioning	Replace the thermostat
Cooling system is blocked	Locate the problem and clean
Closed cooling circuit is dirty	Clean and rinse
Loss of pressure in the closed cooling circuit	Check there are no leaks. Clean, inspect and check the fill cap
Coolant is unsuitable	Use the recommended coolant (see technical specifications)