

HX10E 2000X540

LIFTING STABILITY



HX10

The HX10 series, which is available in both a manual and an electric version, allows for easy and light lifting to a height of 800 mm, thus becoming a practical work platform, which is suitable for places such as machine workshops. This pallet truck is also able to carry out the support function and material supply along the assembly and production lines.

CONTROL LEVER

The redesigned hydraulic unit allows for less effort at the steering wheel for all loads and a quick elevated function (30 cycles) for loads up to 150 kg.



EMERGENCY PUSHBUTTON

The emergency pushbutton with a battery cut-off (isolator) switch function and an off-load valve allows for a smoother lowering of the load; these are some of the devices that make the work safer and more efficient.



FRONT AND REAR STABILISERS

The new control linkage makes the entry onto the closed side of the pallet possible by slight lifting, which facilitates the successive handling phases. Furthermore, more machine stability has been obtained using load rollers in a more advanced position and by providing front stabilisers as a standard.

Rear stabilizers, in turn, render work stable and safe even in the case of elevated loads once the 400 mm of lifting up have been exceeded.



PHOTO AUTO LEVELING SYSTEM

- An automatic system which, by means of a photocell, adjusts the height of the forks, thus maintaining the work height set.
- An optical and acoustic signal is activated at every fork movement.
- Possibility of adjusting the photocell both in height and reading angle.
- Micro-switch, active both on the way up to prevent superfluous absorption of energy and on the way down to protect the operator.



Kennzeichen

1.1 Hersteller				LIFTER
1.3 Antrieb				Manuell
1.4 Bedienung				Begleitend
1.5 Tragfähigkeit	Q	Kg		1000
1.6 Lastschwerpunkt	c	mm		1000
1.8 Lastabstand	x	mm		1509
1.9 Radstand	y	mm		1748

Gewicht

2.1 Eigengewicht (inkl. Batterie)		Kg		262
2.2 Achslast mit Last hinten		Kg		801
2.2 Achslast, mit Last vorne		Kg		461
2.3 Achslast mit Last vorne		Kg		169
2.3 Achslast mit Last hinten		Kg		93

Fahrwerk/Räder

3.1 Räder: Lenkräder				Gummi
3.1 Räder: Lastrollen				POLY.I.
3.2 Reifengröße, hinten - Breite		mm		50
3.2 Räder Abmessung: Lenkräder - Durchmesser		mm		200
3.3 Reifengröße, hinten - Durchmesser		mm		80
3.3 Reifengröße, hinten - Breite		mm		50
3.5 Reifengröße: hinten - Anzahl (X=angetrieben)		Anzahl		2
3.6 Spurweite, vorn	b10	mm		155
3.7 Spurweite, hinten	b11	mm		447

Grundabmessungen

4.4 Hub	h3 mm	715
4.9 Höhe Deichsel in Fahrstellung max.	h14 mm	1300
4.9 Höhe Deichsel in Fahrstellung min.	h14 mm	915
4.15 Höhe gesenkt	h13 mm	85
4.19 Gesamtlänge	l1 mm	2543
4.20 Länge einschl. Gabelrücken	l2 mm	540
4.21 Gesamtbreite	b1 mm	540
4.22 Gabelzinkenmaße - Dicke	s mm	48
4.22 Gabelzinkenmaße - Breite	e mm	160
4.22 Gabelzinkenmaße - Länge	l mm	2000
4.25 Gabelaußenabstand	b5 mm	540
4.32 Bodenfreiheit, Mitte Radstand	m2 mm	21
4.34 Arbeitsgangbreite bei Palette 800x1200 quer	Ast mm	2763
4.35 Wenderadius	Wa mm	2058

Leistungsdaten

5.2 Hubgeschwindigkeit mit Last	m/s	0.08
5.2 Hubgeschwindigkeit ohne Last	m/s	0.13
5.3 Senkgeschwindigkeit mit Last	m/s	0.13
5.3 Senkgeschwindigkeit ohne Last	m/s	0.06

E - motor

6.2 Hubmotor, Leistung	kW	1.6
Batterietyp	Type	Starter (C20)
6.4 Batteriespannung	V	12
6.4 Batterie Kapazität, min	Ah	60
6.4 Batterie Kapazität, max	Ah	60
6.5 Batteriegewicht, min	Kg	14
6.5 Batteriegewicht, max	Kg	14

*Battery and external battery charger
 Also available in GEL version and with an integrated battery charger

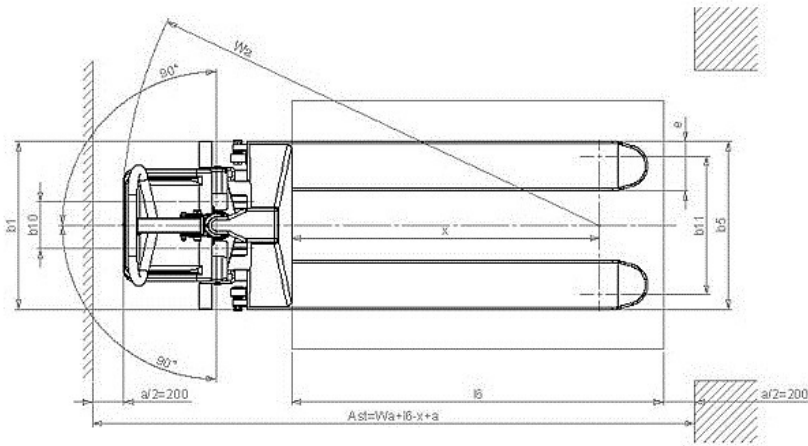
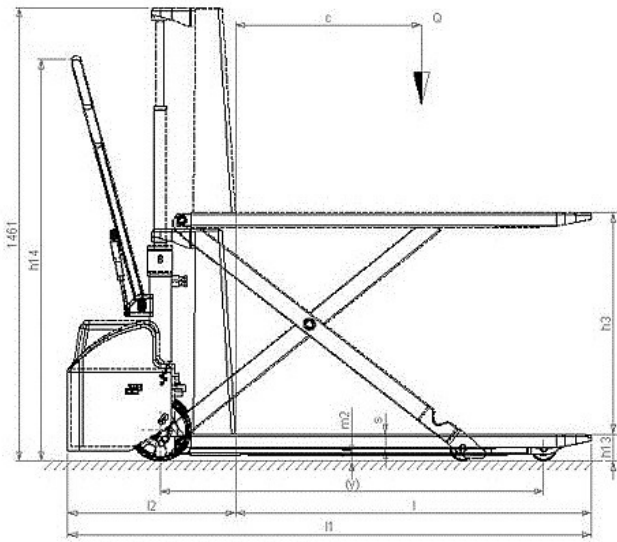

www.pramac.com

The information is aligned with the Data file at the time of download. Printed on 12/10/2017 (ID 485)

©2017 | PR INDUSTRIAL s.r.l. | All rights reserved | Image shown may not reflect actual package.
 Specifications subject to change without notice

