

TECHNICAL DATA SHEET



ALTERNATOR E1S10M G

Three-Phase synchronous alternator with brushes and compound - 2 poles

E1S10M G

COMMON DATA

Rated Power at 50Hz	kVA	5,5	
Rated Power at 60Hz	kVA	7,0	
Rated Power Factor		0,8	
Nominal Temperature	°C	40	
Control System		self-excited	
Execution		with brushes	
Regulation Type		compound	
Insulation Class		H	
Protection		IP21	
Maximum Over speed	rpm	4500	
Overload		110% of rated power for one hour in a cycle of 6 hours	
Air Flow Requirement	m ³ /min	3,7 at 50Hz	4,6 at 60Hz
R.F.I. Suppression		Standard EN55011	

REGULATION DATA

Compound		compound
Voltage Regulation		±4%
Sustained Short Circuit		> 300% of rated current

WINDING DATA

Stator Winding		Single layer with auxiliary winding
Rotor Winding		with damping cage
Number of Leads of Stator		6
Stator Winding Resistance	Ω	1,8 at 20°C
Rotor Winding Resistance	Ω	19,5 at 20°C
THD at full load		<4% (L-L)
THD at no load		<3% (L-L)
Excitation at no Load	Adc	1,3
Excitation at full Load	Adc	4,0

STANDARD

References	EN60034-1 ISO8528-3 EN55011
------------	-----------------------------

ON REQUEST

UL 1446, Systems of Insulating Materials - General CSA-C22.2 No. 0, Appendix B, General Requirements - Canadian Electrical Code, Part I

E1S10M G

ELECTRICAL DATA

Frequency		50Hz - 3000rpm	60Hz - 3600rpm
Voltage Series Star	V	400/230	480/277
Rated Power in Class H (125°C/40°C)	kVA	5,5	7,0
	kW	4,4	5,6
Rated Power in Class F (105°C/40°C)	kVA	5,0	6,5
	kW	4,0	5,2

EFFICIENCY IN CL. H

4/4	78,5%	79,0%
3/4	79,0%	80,0%

REACTANCES AND TIME CONSTANTS

Pcc	0,50
X _d - dir. axis synchronous	265%
X' _d - dir. axis transient	19,0%
X'' _d - dir. axis subtransient	7,0%
X _q - quad. axis reactance	145%
T' _{do} - O.C. field time constant	420ms
T' _d - Transient time constant	30ms
T'' _d - Sub-transient time constant	5ms

MECHANICAL DATA

Bearing non drive end	6204-2Z-C3	
Bearing drive end (B3/B14 form)	6305-2Z-C3	
Weight of generator	in B2 kg	\
	in B3/B14 kg	29,4
	in B3/B9 kg	28,7

E1S10M G

MOMENT OF INERZIA

B3/B9	kg·m ²	0,013
B3/B14	kg·m ²	0,013

DERATING CURVES

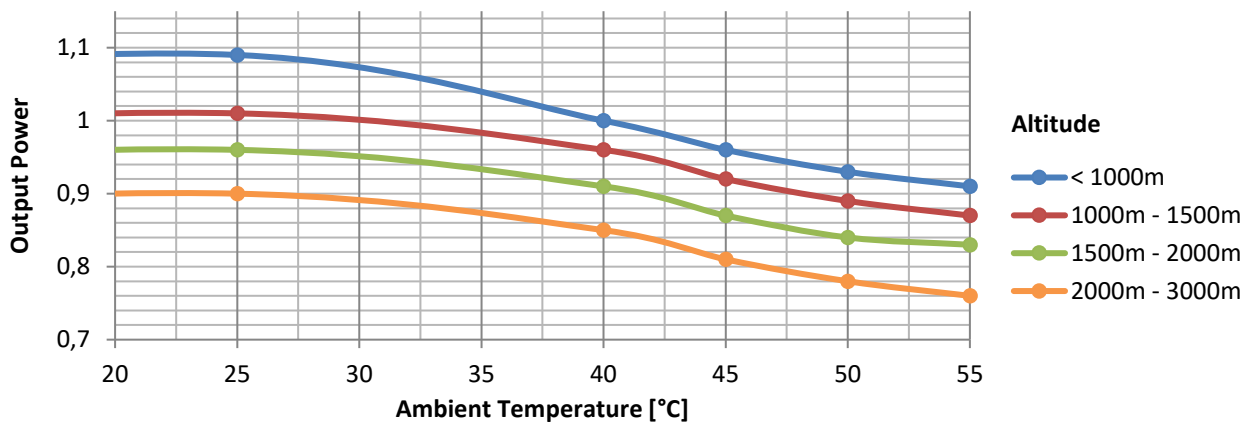

WIRING DIAGRAM

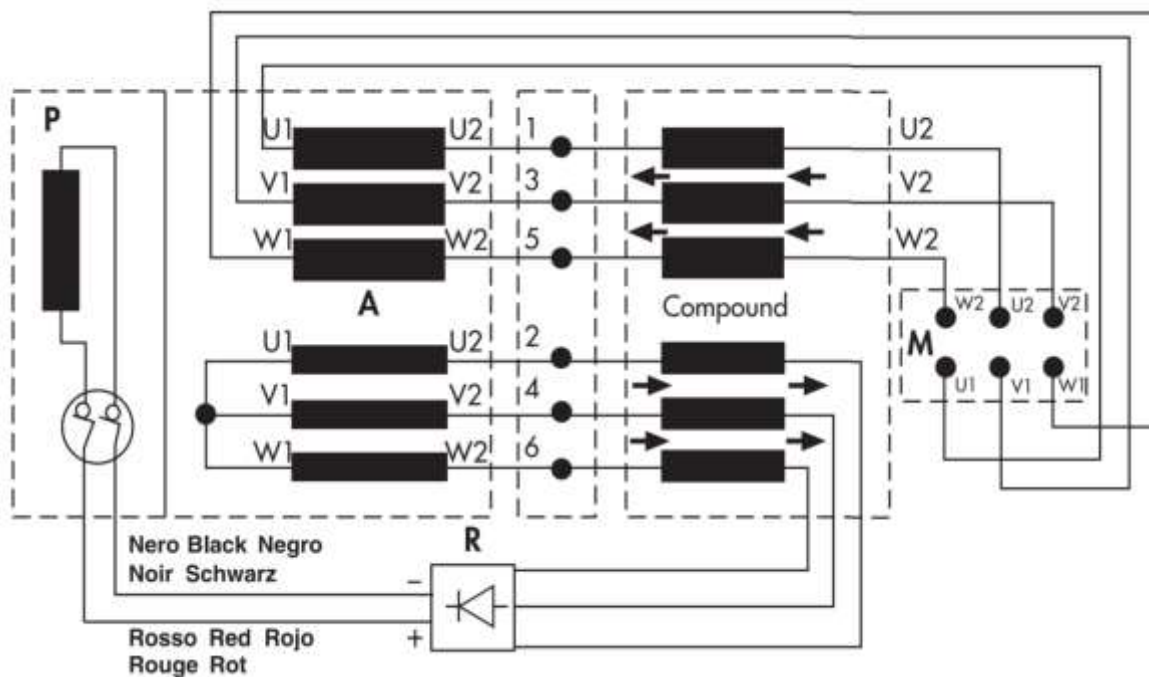

E1S10M G

TRANSIENT VOLTAGE VARIATION 50Hz

Transient Voltage Variation @ 50Hz

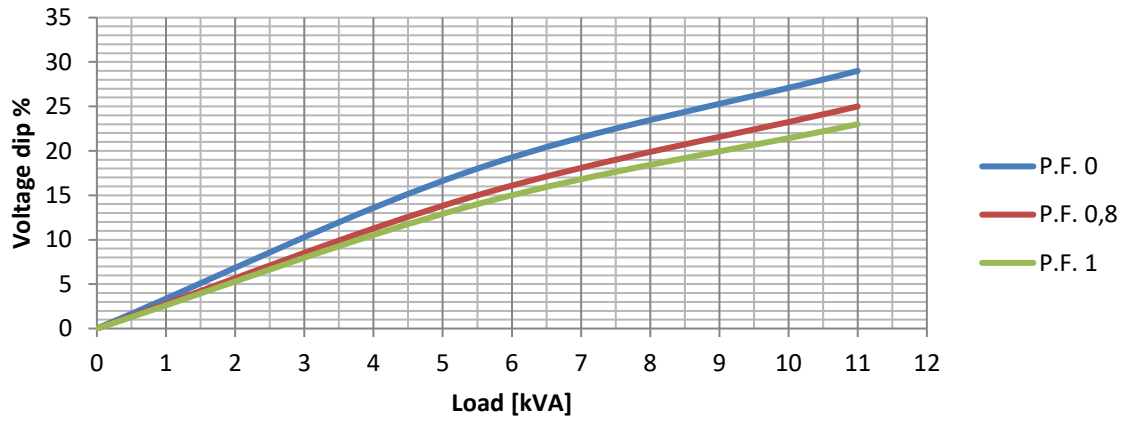

TRANSIENT VOLTAGE VARIATION 60Hz

Transient Voltage Variation @ 60Hz

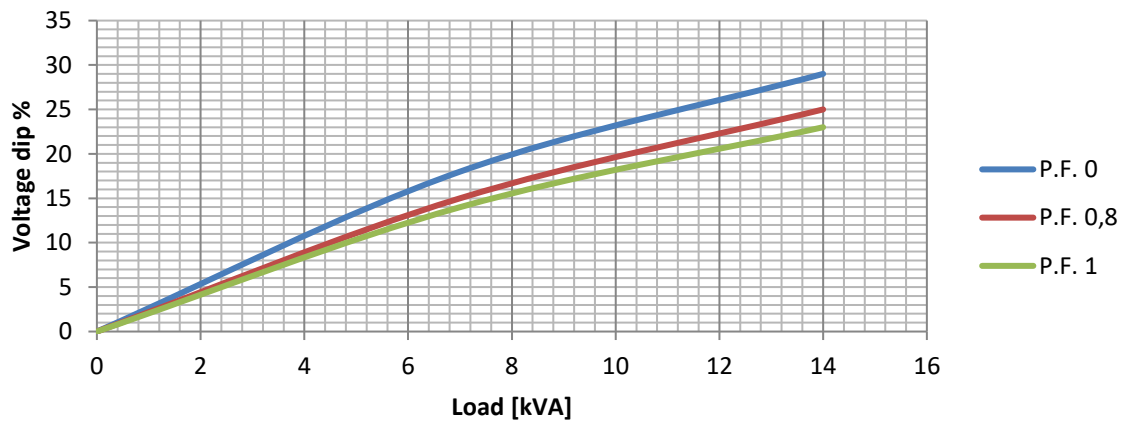

E1S10M G

FORMA FORM FORME B3/B9

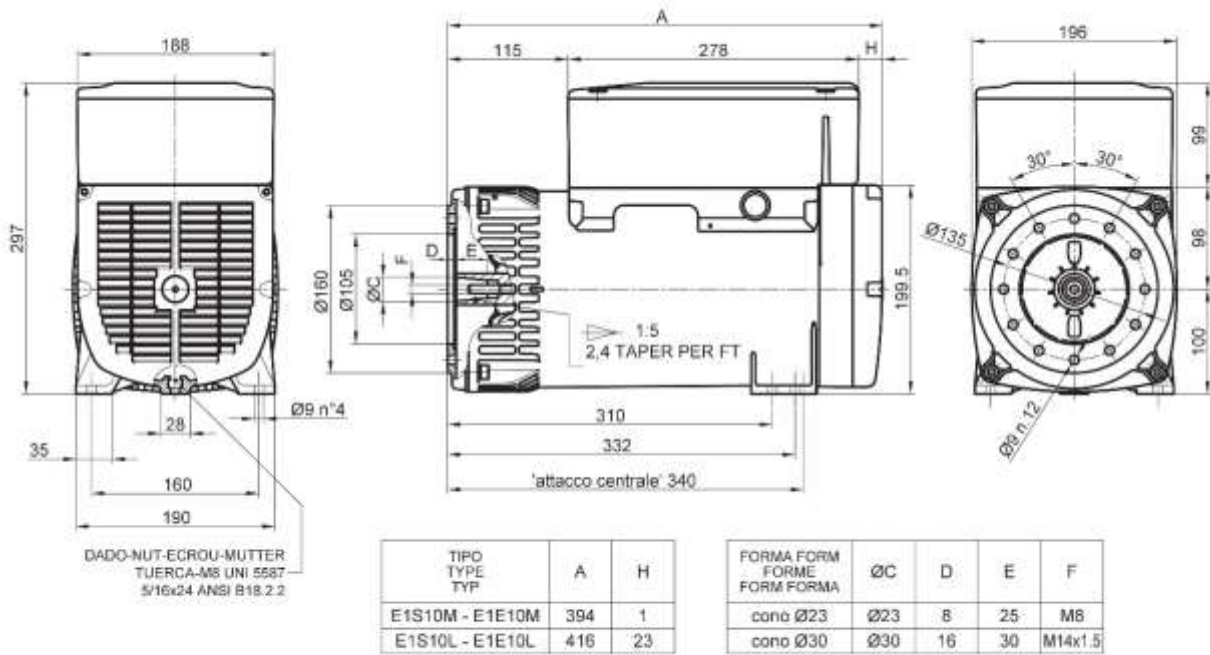

DADO-NUT-ECROU-MUTTER
TUERCA-M8 UNI 5687
5/16x24 ANSI B18.2.2

FORMA FORM FORME B3/B14

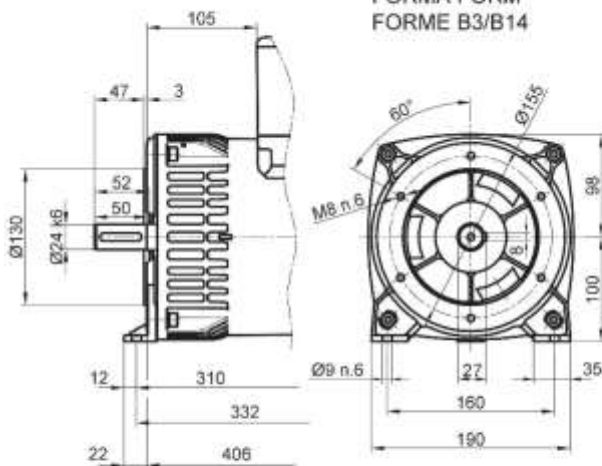

FORMA FORM FORME J609a

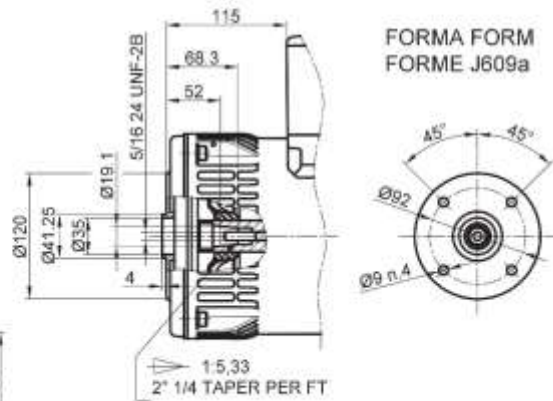

FORMA FORM FORME J609b

